

OAK-D Pro W — DepthAI Hardware Documentation

1.0.0 documentation

OAK-D Pro W



Overview

The **OAK-D Pro W** has **Wide Field of View (FOV) cameras** and features an **IR laser dot projector** (active stereo) and **IR illumination LED** (for night-vision). The OAK-D Pro W is from the Series 2 of OAK cameras.

Compared to the OAK-D S2, the only differences are:

- IR laser dot projector and IR illumination LED (Pro aspect of the version)
- Wide FOV cameras (W aspect of the version)

Due to the large power consumption of dot projector/illumination LED, a Y-adapter is required when using these functions!

Hardware specifications

This OAK camera uses USB-C cable for communication and power. It supports both USB2 and USB3 (5Gbps / 10Gbps).

Camera module specifications

Wide FOV IMX378

Wide FOV OV9782

For the wide FOV version you can select **either** 120° DFOV IMX378 (12MP) **or** 150° DFOV color OV9782 (1MP) color camera.

Camera Specs	Color camera	Stereo pair
Sensor	<u>IMX378</u> (PY060)	<u>OV9282</u> (PY059)
DFOV / HFOV / VFOV	120°/95°/70°	150°/128°/80°
Rectified Depth FOV	N/A	106°/97°/70°
Resolution	12MP (4056x3040)	1MP (1280x800)
Focus	FF: 60cm - ∞	FF: 18cm - ∞
Max Framerate	60 FPS	120 FPS
F-number	2.8 ±5%	2 ±5%
Lens size	1/2.3 inch	1/4 inch
Effective Focal Length	2.75mm	1.69mm
Distortion	< -14.6%	< 38%
Pixel size	1.55µm x 1.55µm	3µm x 3µm

Wide FOV lenses can only be fixed-focus.



Left: normal FOV, Right: Wide FOV

How it works

This OAK model has notch IR filters at 940nm on the stereo camera pair, which allows both visible light and IR light from illumination LED/laser dot projector to be perceived by the camera.

Laser dot projector projects many small dots in front of the device, which helps with disparity matching, especially for low-visual-interest surfaces (blank surfaces with little to no texture), such as a wall or floor. The technique that we use is called ASV - conventional Active Stereo Vision - as stereo matching is performed on the device the same way as on OAK-D (passive stereo).

Note

Laser dot projector and flood LED are disabled by default! That's because most people would prefer intentionally enabling the laser dot projector when they are wearing eye safety gear.

On the image below there's a blank wall with no texture. Without the dot projector, (passive) depth perception is poor. With the dot projector set to ~200mA, the (active) depth perception looks much better. If you look closely at the bottom left frame, you can see little dots all around the wall.

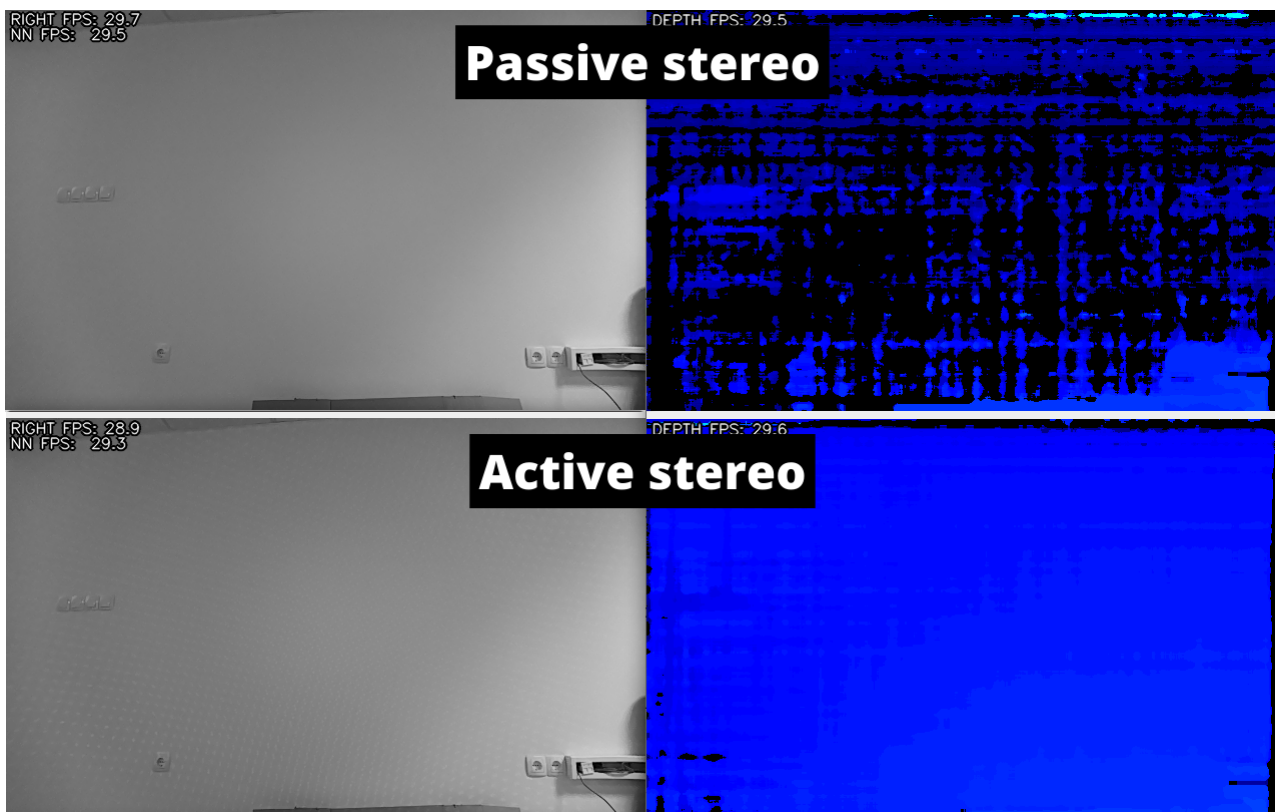

Flood IR LED illumination allows perceiving low-light and no-light environments. You can run your AI/CV processes on frames that are illuminated by the IR LED. Note that the color camera doesn't perceive IR light, so you would need to use a mono camera stream for your AI/CV processes.



Getting started

You can set IR laser dot projector and illumination LED via the API as below. **Note** that the dot projector will be **strongest at 765mA**, as above that, the duty cycle will decrease.

```
# Either within Script node:
script = pipeline.create(dai.node.Script)
script.setScript("""
    Device.setIrLaserDotProjectorBrightness(500)
    Device.setIrFloodLightBrightness(0)
    """)
```

with `dai.Device(pipeline)` as device:

```
# Or, using the dai.Device object from the host:
device.setIrLaserDotProjectorBrightness(100) # in mA, 0..1200
device.setIrFloodLightBrightness(0) # in mA, 0..1500
```

You can set these two parameters in **DepthAI Demo** in the *Depth* tab:

Projector specifications

Projector Specs	Value
-----------------	-------

Projector Specs	Value
Dot projector	Ams Belago1.1 Dot-Pattern Infrared Illuminator
Number of dots	4700
HFOI* 50%	78 ± 7%
VFOI* 50%	61° ± 7%
VSCEL wavelength	940nm
Operating temperature	10°C to ~60°C
Temperature absolute limits	0°C to ~80°C
PDF	Click here

FOI = Field of illumination. Also note that in datasheet, HFOI and VFOI are switched, that's because we mount the Belago1.1 rotated as we want greater horizontal field, to match field of cameras.

Regarding operating temperature; some customers use dot projector even at lower ambient temperatures, but first wait a few minutes for device to heat up (by running AI/CV/stereo depth...) so projector gets to above 0°C.

RVC2 inside

This OAK device is built on top of the [RVC2](#). Main features:

- **4 TOPS** of processing power (1.4 TOPS for AI - [RVC2 NN Performance](#))
- **Run any AI model**, even custom-architected/built ones - models need to [be converted](#).
- **Encoding:** H.264, H.265, MJPEG - 4K/30FPS, 1080P/60FPS
- **Computer vision:** warp/dewarp, resize, crop via [ImageManip](#) node, [edge detection](#), [feature tracking](#). You can also [run custom CV functions](#)
- **Stereo depth** perception with filtering, [post-processing](#), [RGB-depth alignment](#), and high [configurability](#).
- **Object tracking:** 2D and 3D tracking with [ObjectTracker](#) node

Dimensions and Weight

Weight: 91g

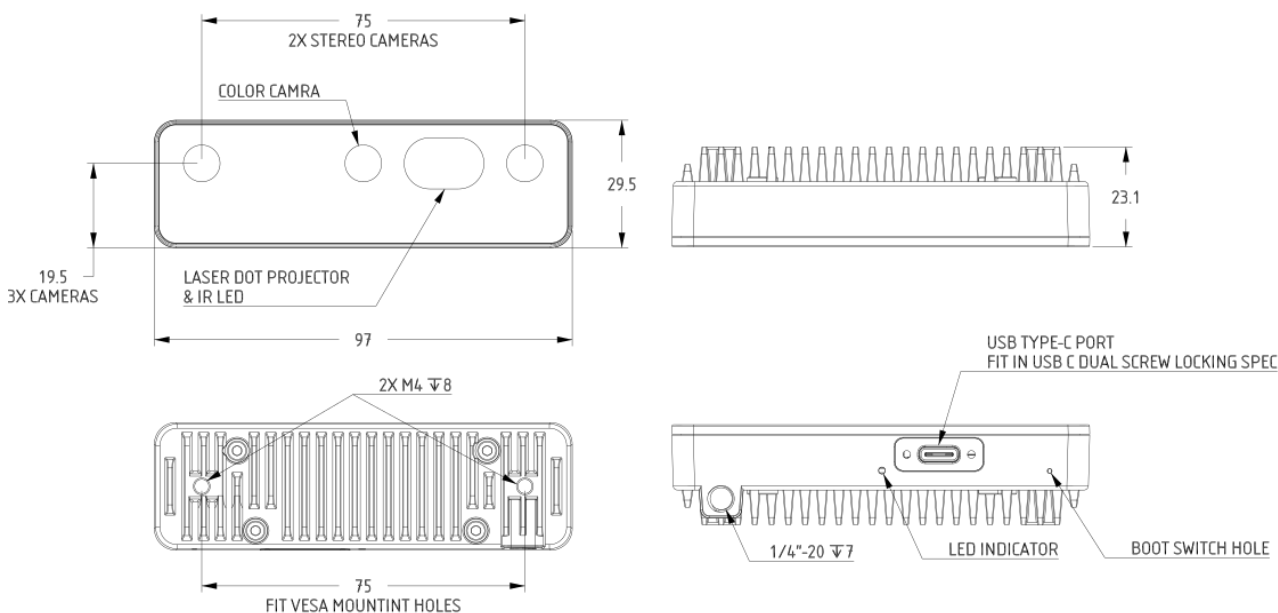

Stereo depth perception

This OAK camera has a baseline of 7.5cm - the distance between the left and the right stereo camera. Minimal and maximal depth perception (MinZ and Max) depends on camera FOV, resolution, and baseline- more information [here](#).

- Ideal range: 70cm - 8m
- MinZ: ~20cm (400P, extended), ~35cm (400P **OR** 800P, extended), ~70cm (800P)
- MaxZ: ~15 meters with a variance of 10% ([depth accuracy evaluation](#))

Extended means that StereoDepth node has Extended disparity mode enabled.

Integrated IMU

This OAK camera has an integrated **BNO085**, a **9-axis IMU** (Inertial Measurement Unit). See [IMU node](#) for the API details on how to use it.

Note: due to supply chain issues, most of the OAK camera that were manufactured between Q2 2021 and Q2 2023 have integrated BMI270 - 6-axis IMU instead.

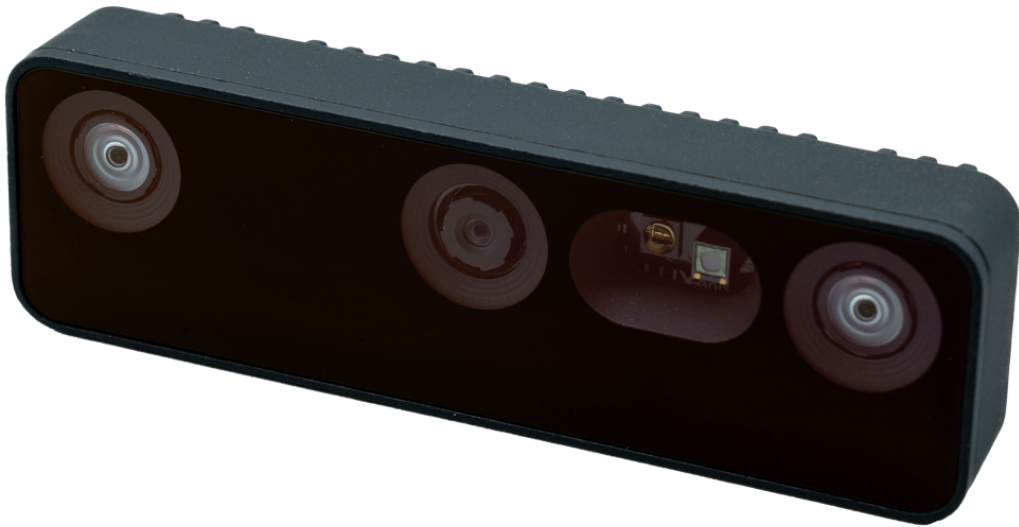

Laser safety

This product is classified as a Class 1 Laser Product under the EN/IEC 60825-1, Edition 3 (2014) internationally.

- Do not power on the product if any external damage was observed.
- Do not attempt to open any portion of this laser product.
- Invisible laser radiation when opened. Avoid direct exposure to the beam.
- There are no user serviceable parts with this laser product.
- Modification or service of the stereo module, specifically the infrared projector, may cause the emissions to exceed Class 1.
- No magnifying optical elements, such as eye loupes and magnifiers, are allowed.
- Do not try to update camera firmware that is not officially released for specific camera module and revision.

