

Relay Expansion

The Relay Expansion allows you to control two other independent, external circuits using the Omega. These circuits are safely isolated from the Omega and can be either lower or higher voltage; see the maximum ratings in the table in the article below for more details.

Never exceed the maximum electrical ratings of the relays or you risk damaging the Relay Expansion, Omega, or even starting a fire.

This Expansion communicates with the Omega using the I2C protocol. The Expansion's I2C device address is configurable by the address switches and ranges from $0x20$ to $0x27$. If you're curious, check out the [article on I2C](#).

The Relay Expansion is designed so you can stack multiple Relay Expansions onto the same Omega. Each board comes with a small switch used to give it a unique address, and up to 8 Relay Expansions can be controlled by a single Omega. This means you can control up to 16 external circuits and devices!

The Hardware

The Relay Expansion comes with two electromagnetic relays with screw terminals.

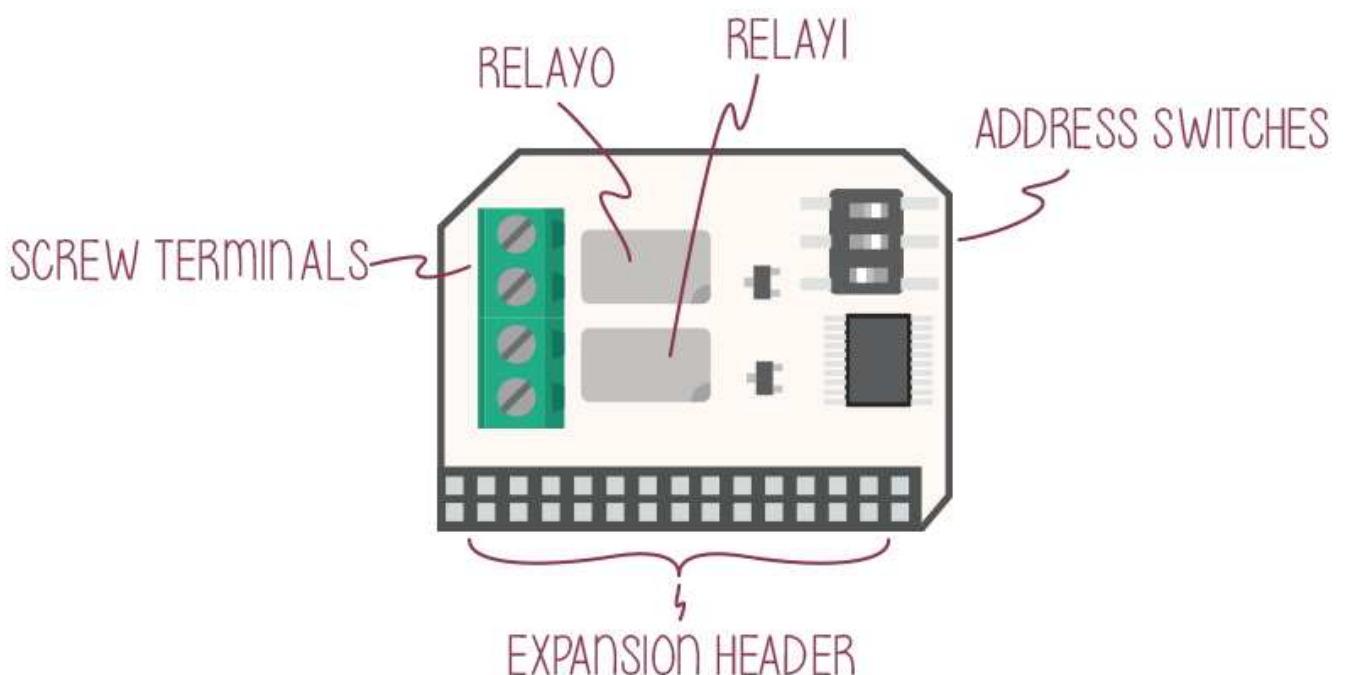

Connecting to a Dock

You can use the Relay Expansion with the Expansion Dock, Power Dock, or Arduino Dock R2. You can also safely stack other Expansions on top of it.

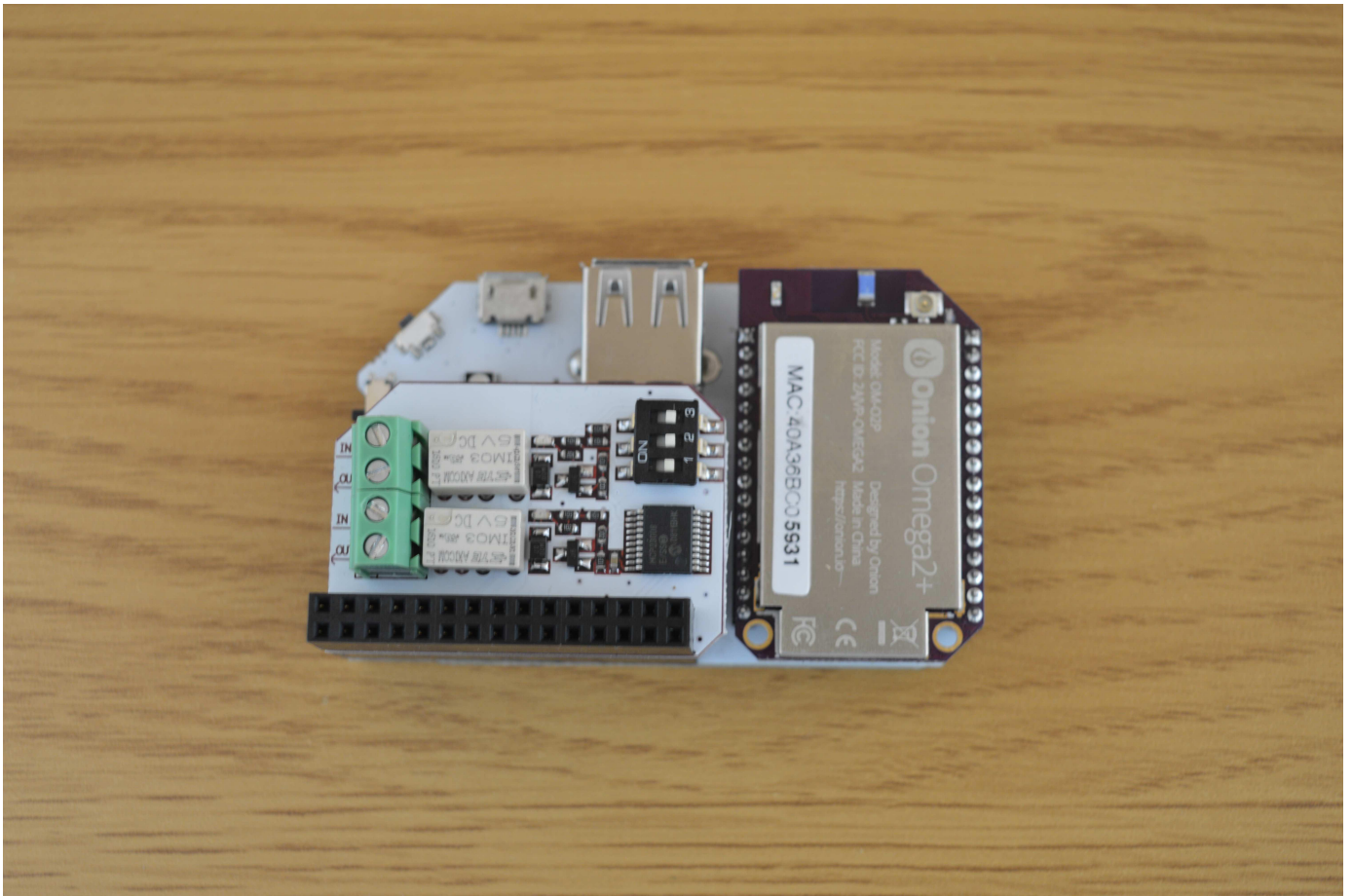

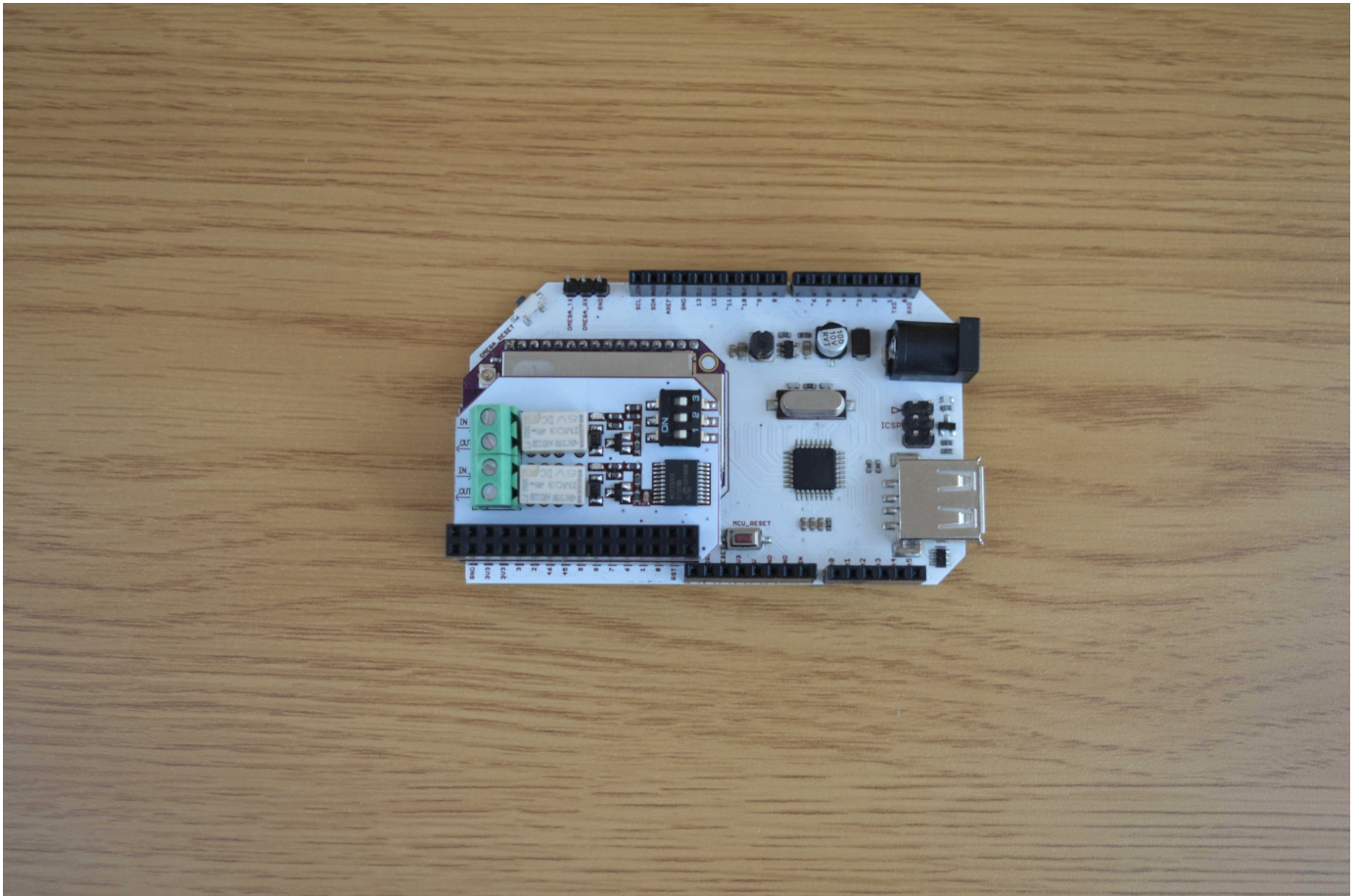
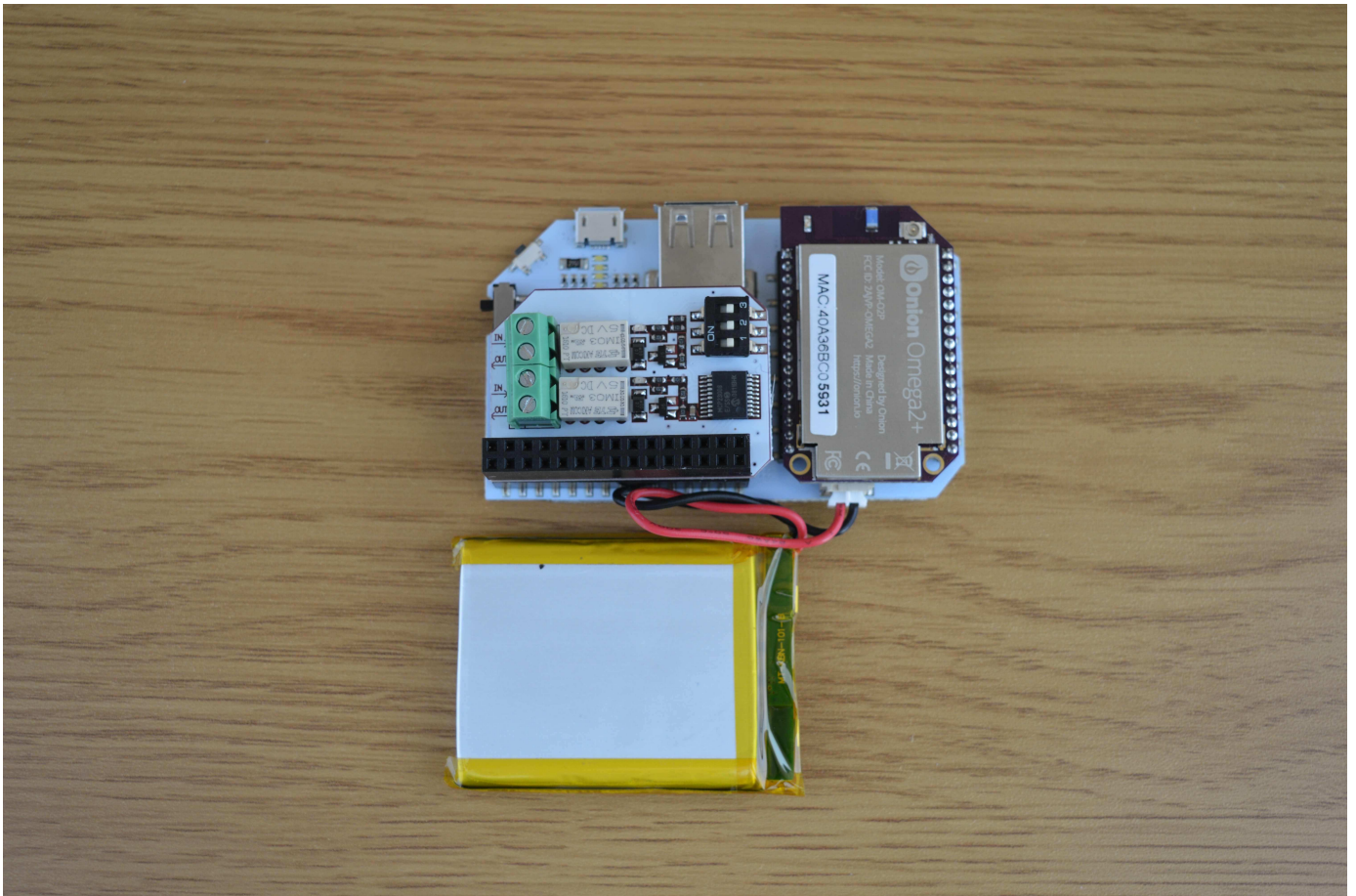

To connect the Relay Expansion to the Omega, plug it into the Expansion Header on the Expansion Dock.

The Relays

Relays are simple switches that can open (disconnect) and close (connect) circuits. Take the following example circuit:

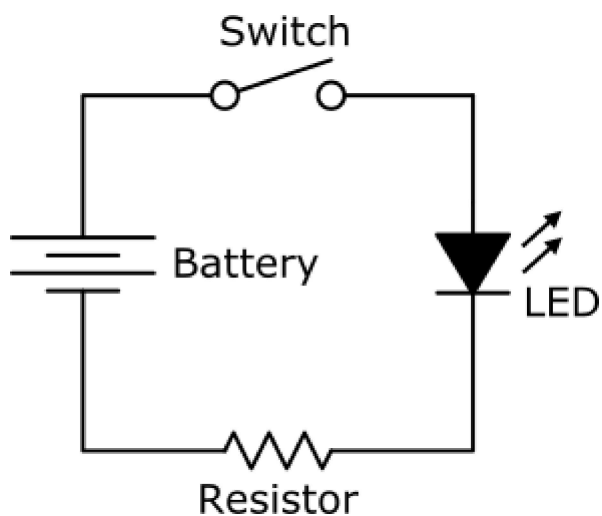

In the above diagram, the function of the Switch can be performed by a single relay.

The Relay Expansion uses two TE Axicom IM03 relay modules. Some of the specifications are shown below:

Parameter	Specification
Maximum Switching Voltage	220VDC, 250VAC
Current Rating	2A
Switching Power	60W, 62.5VA
Switching Time	Typical: 1ms Maximum: 3ms

For full specifications, please see the [TE Axicom datasheet](#).

The relays channels are labelled below:

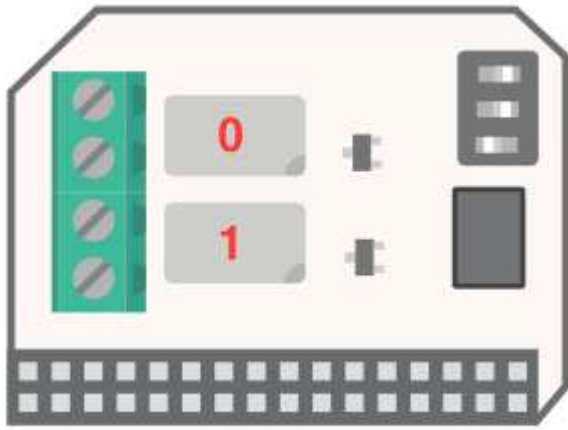

The Screw Terminals

The green block on the board is called the *terminal block*. It houses 4 terminals, 2 for each relay, into which you plug your circuit wires. To secure the wires inside the terminal block, screw them down with a small flathead screwdriver.

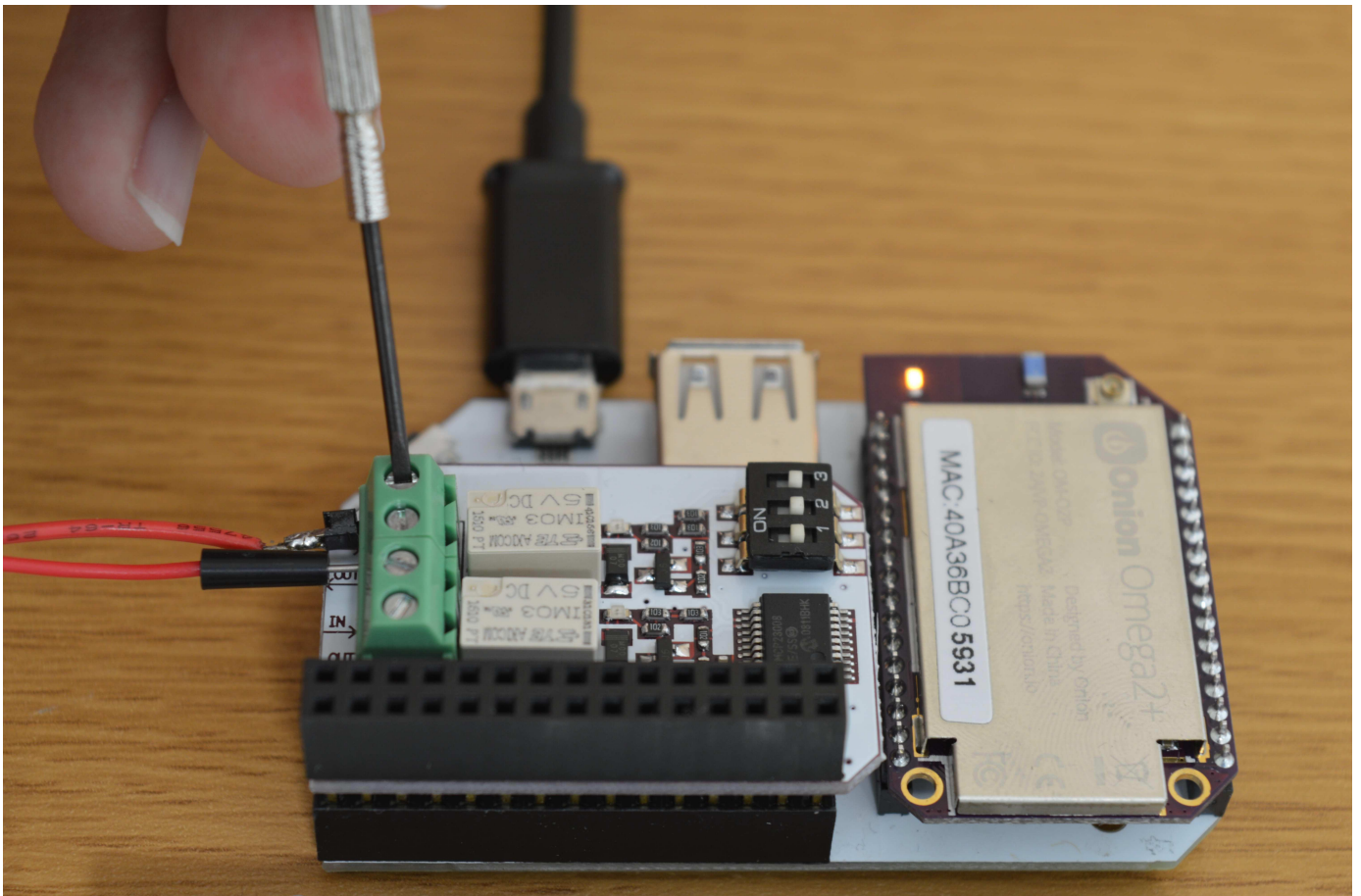

The Address Switch

The address switch allows you to change the I2C address of the board. This is needed to differentiate multiple Relay Expansions from each other when connected to the same Omega.

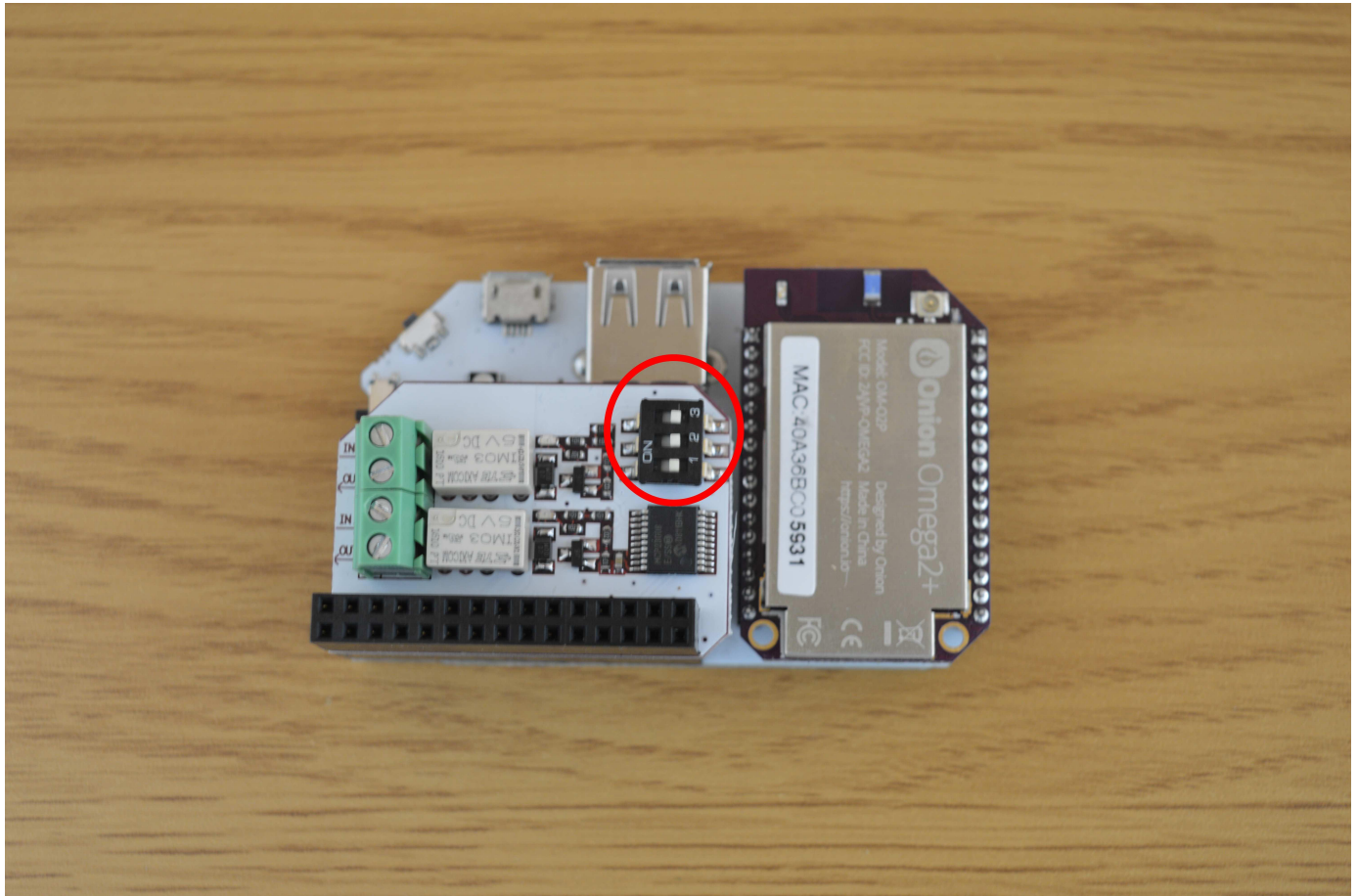

It has 3 switches that can be turned either ON or OFF. See the following table for the address values:

Switch 1	Switch 2	Switch 3	Binary Value
OFF	OFF	OFF	000
OFF	OFF	ON	001
OFF	ON	OFF	010
OFF	ON	ON	011
ON	OFF	OFF	100
ON	OFF	ON	101
ON	ON	OFF	110
ON	ON	ON	111

The I2C addresses corresponding to the different switch positions are shown below:

I2C Device Address	Switch Binary Setting
0x27	000
0x26	100
0x25	010
0x24	110
0x23	001
0x22	101
0x21	011
0x20	111

Mechanical Drawings

We've made available a detailed [diagram](#) of the dimensions and geometry of the Relay Expansion.

Using the Relay Expansion

Consider this LED circuit:

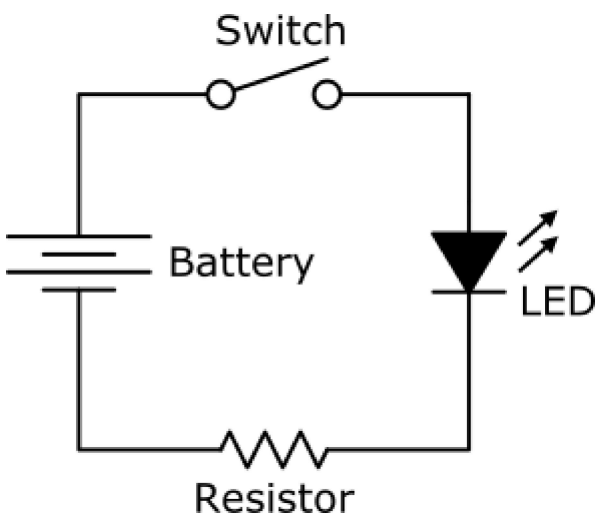

We can build this circuit without the switch:

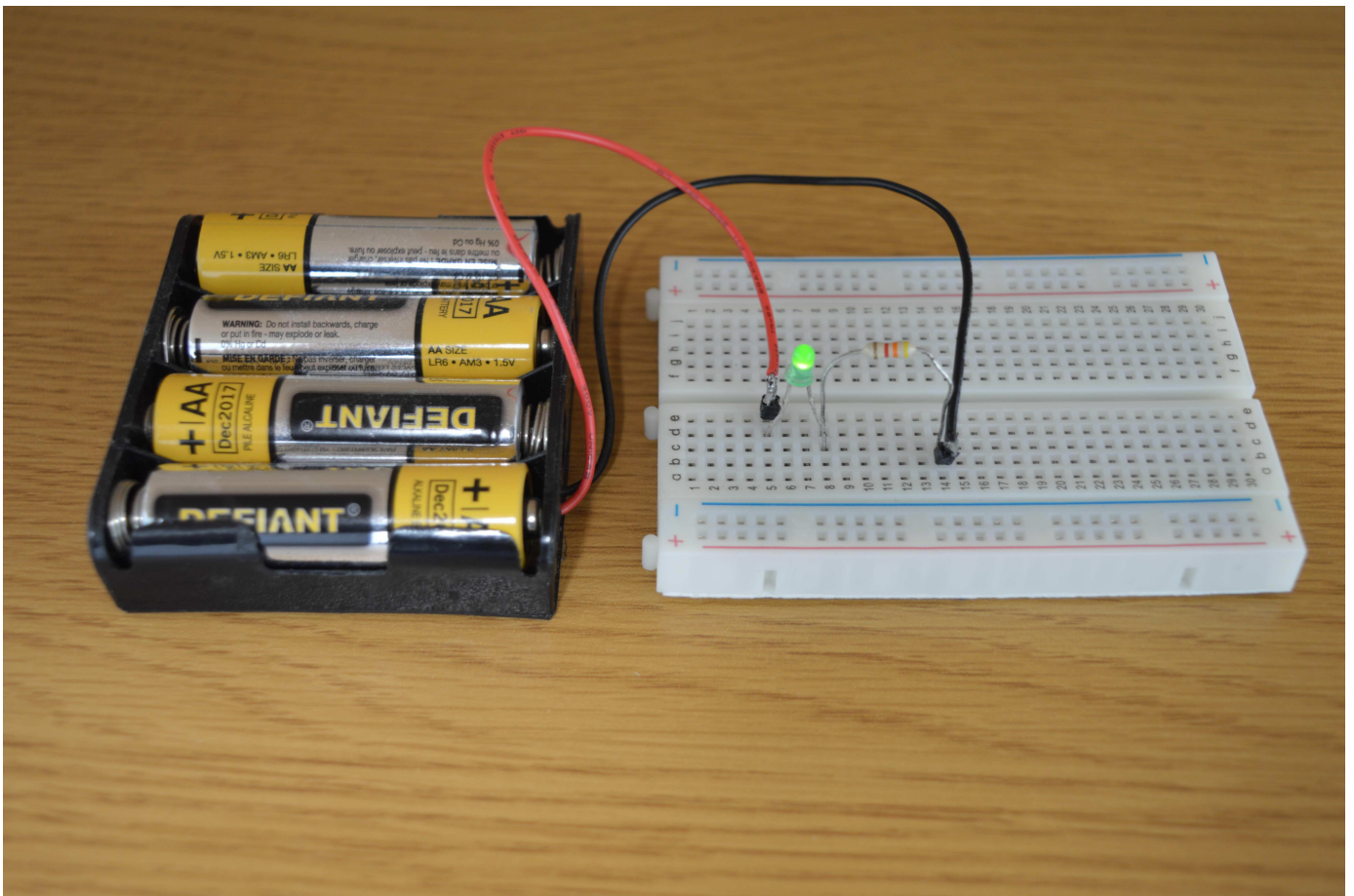

Next, we will add the Omega and Relay Expansion to act as the switch:

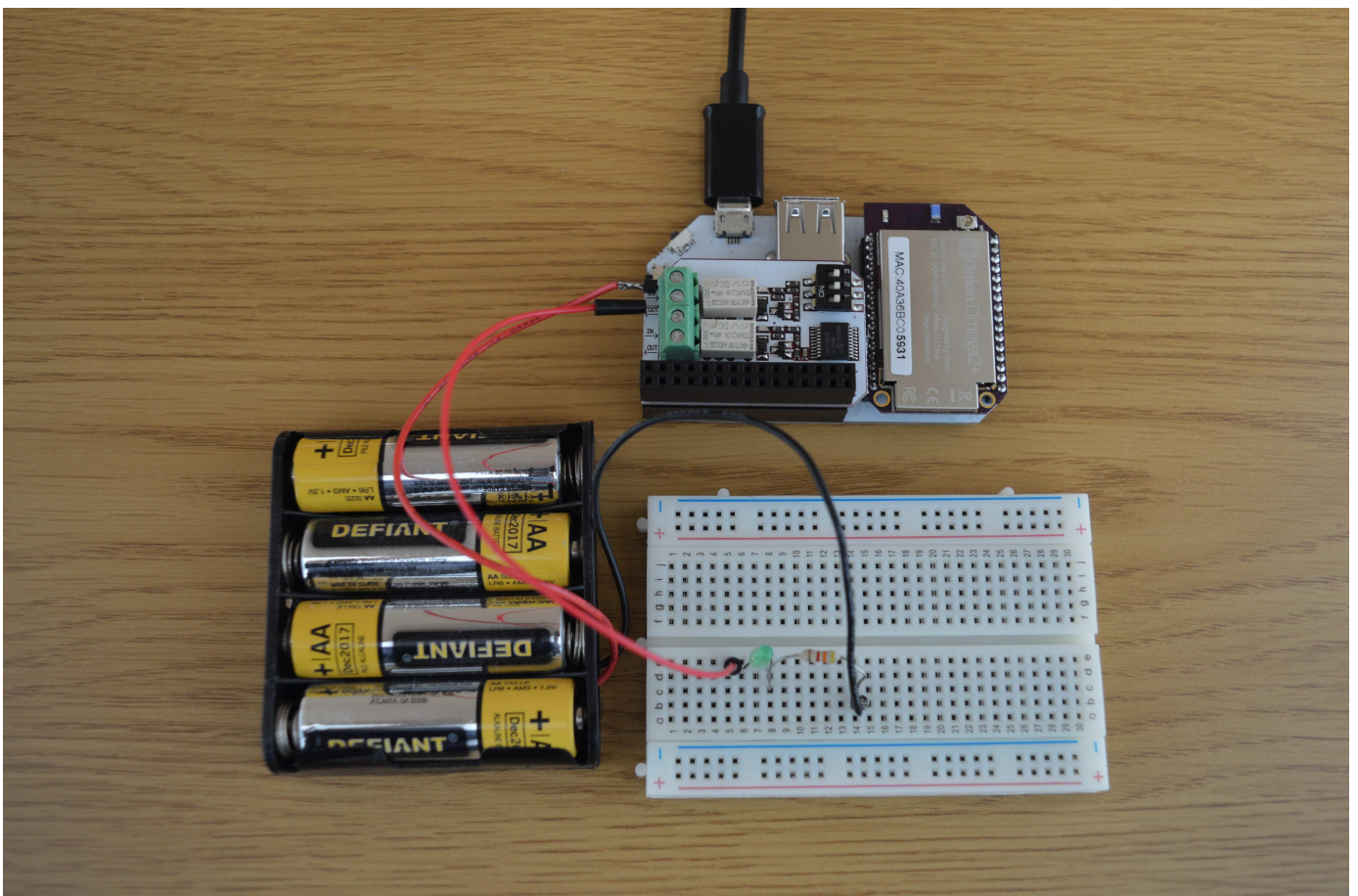

The positive lead of the battery pack is connected to the port labelled IN on the Expansion. A jumper wire is connected from the OUT port back to the circuit. Since the Relay is OFF, the switch is off and no current is passing through the LED:

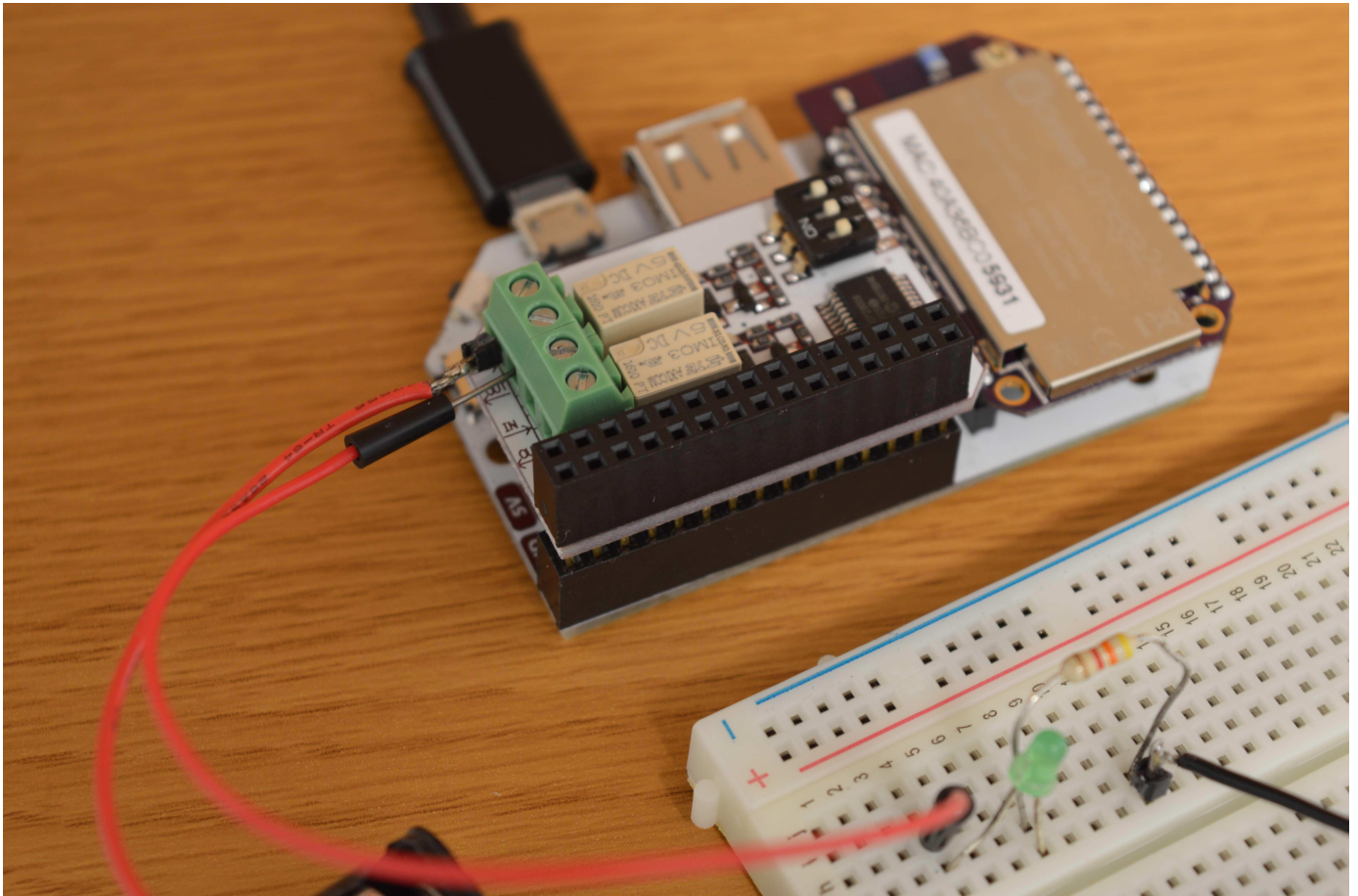

When we turn the relay on, it acts as a closed switch, allowing current to flow through the LED:

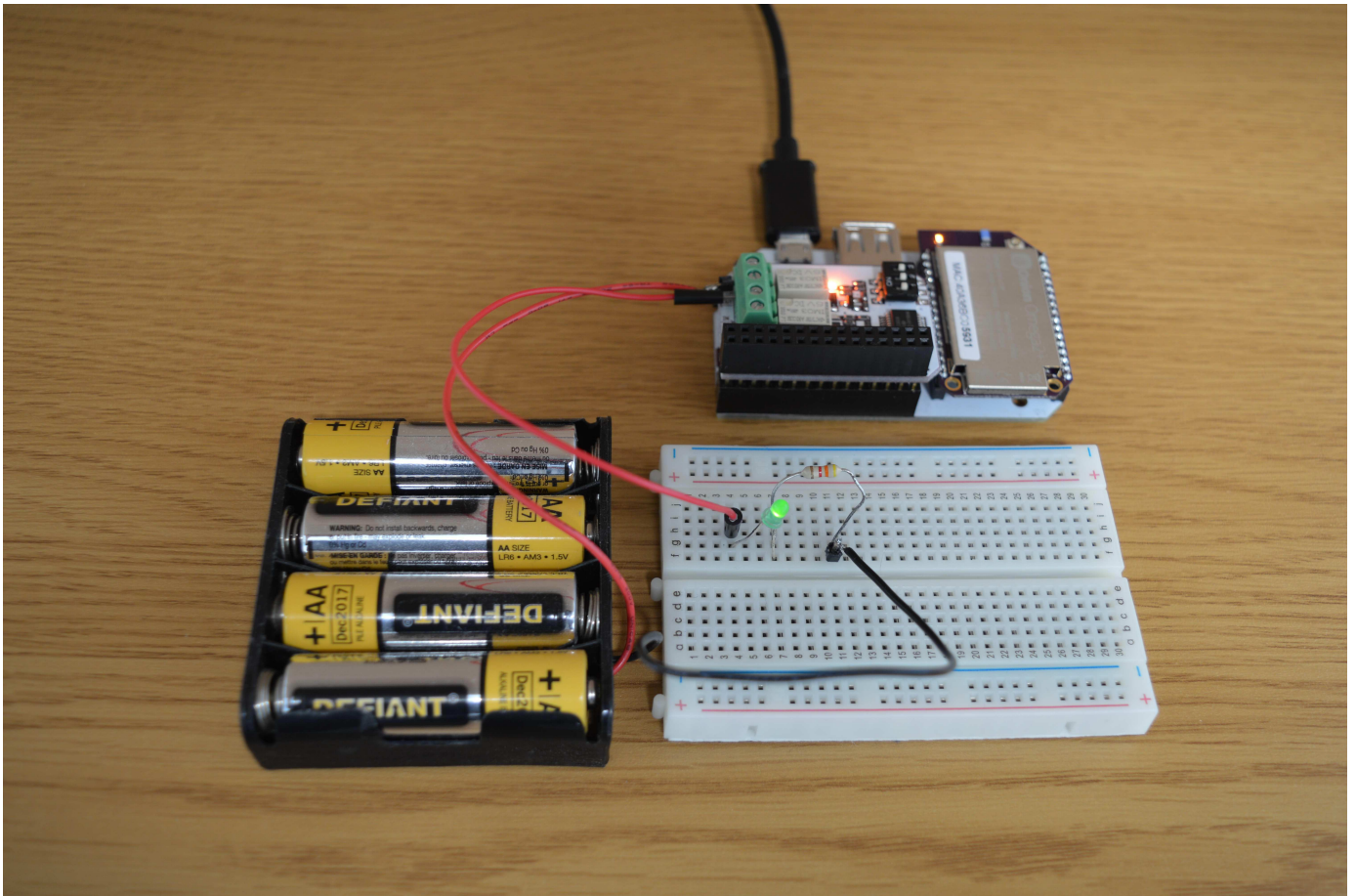

The Relay Expansion can be used to control almost any type of external circuit, such as a lamp, coffee maker, or even your garage door!

Read our [guide to using the Relay Expansion](#) to learn how to control it using software.