

OPTIONAL BACK PANEL SHOWN
 0.100 [2.54mm] TH'K- ALUMINUM
 0.075 [1.91mm] TH'K- WHITE STEEL
 0.188 [4.78mm] TH'K- PVC

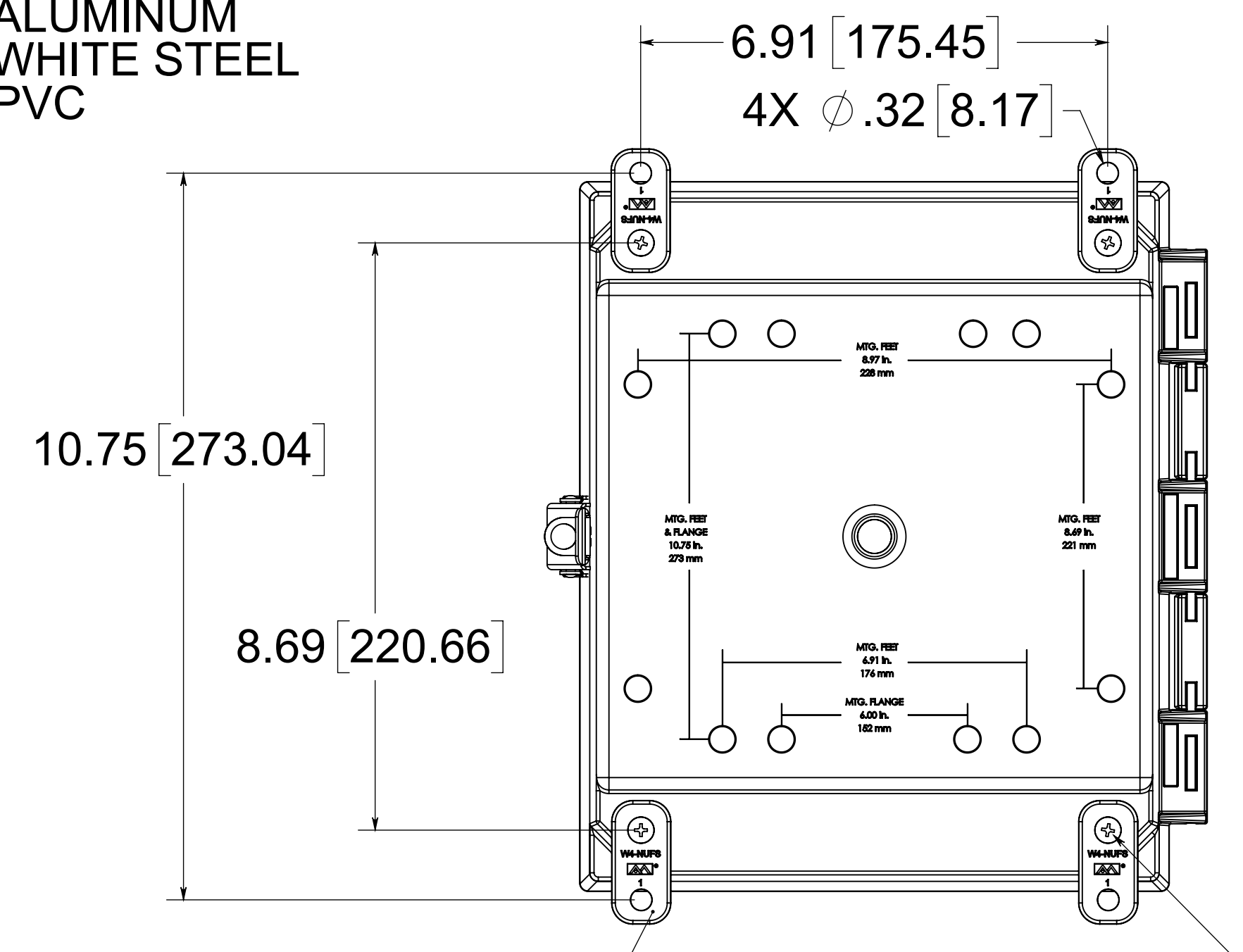

(4) POLYCARBONATE MOUNTING FEET

(4) EACH #10-32 BRASS INSERTS, AND 316 STAINLESS STEEL FLANGE AND FEET SCREWS

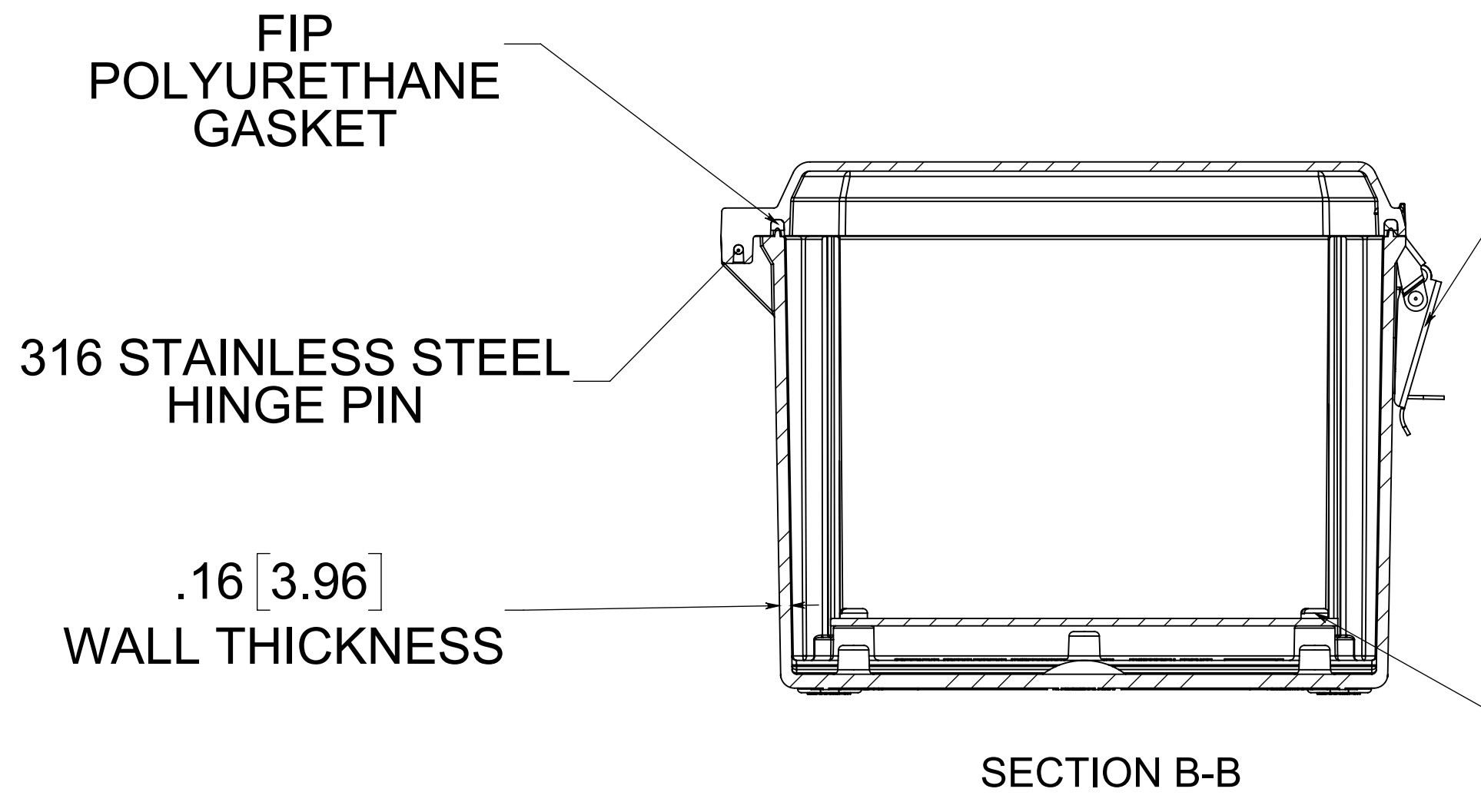

316 STAINLESS STEEL LOCKABLE SNAP LATCH LOCATED ON CENTER

(4) EACH #10-32 BRASS INSERTS AND PLATED CARBON STEEL TRUSS SCREW

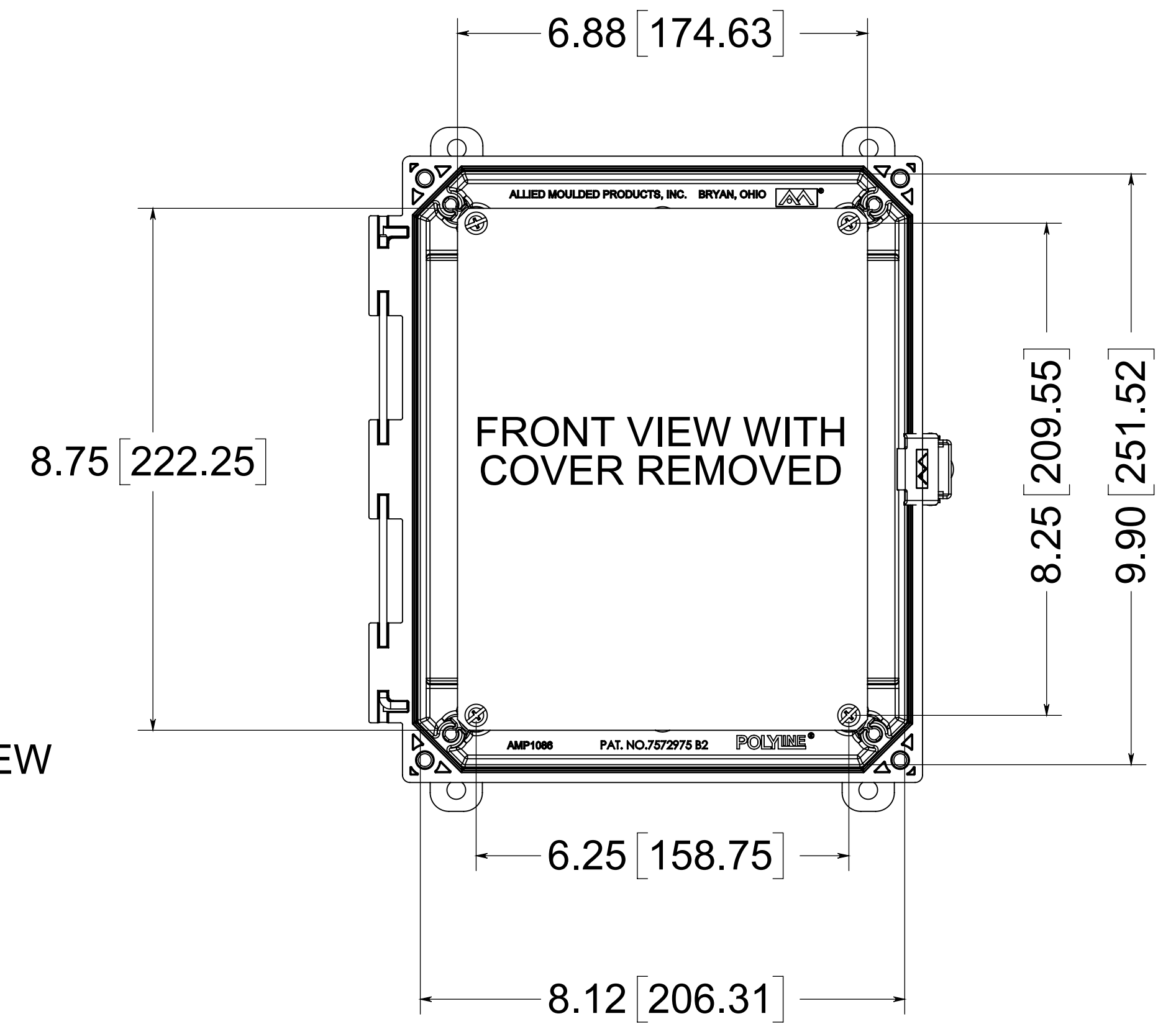

MATERIAL:
 BOX- INJECTED POLYCARBONATE
 STANDARD COVER- INJECTED POLYCARBONATE
 CLEAR COVER - INJECTED POLYCARBONATE

NOTE:
 1. DATA SUBJECT TO CHANGE WITHOUT NOTICE

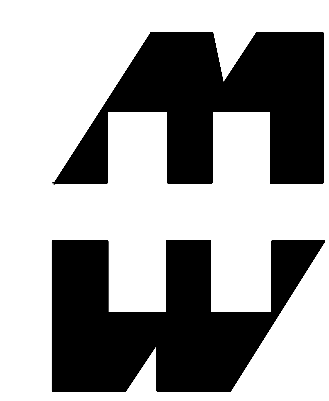

PART No. PCJ1086L

for more information visit www.hammfg.com
 Data subject to change without notice
 Drawing Not to Scale