

Standard Level Sensor

Features

- Polypropylene housing
- FDA test passed
- Covers a wide range of applications
- Ideal for water dispensers, tank monitoring systems, vending machines, coffee machines and printing machines
- IP67 protection rating



Specification @ 25 °C

Output Type	Make Contact (NO)
Contact Rating max.	10 W
Switching Voltage max.	140 VAC / 200 VDC
Switching Current max.	1 A
Carry Current max.	1.2 A
Breakdown Voltage min.	240 VDC
Total Resistance max.	280 mΩ
Operating Temperature	-20 ... 80 °C
Storage Temperature	-30 ... 80 °C
Density of Float typ.*	0.7 g/cm ³
Recommended Minimum Gravity of Medium	Density of Float + 20% g/cm ³

* in delivery condition

Drawing

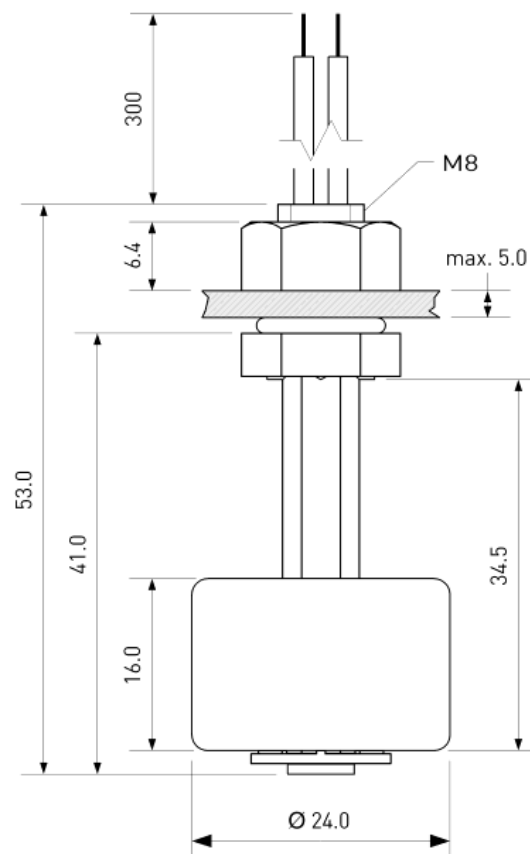

Standard Level Sensor

Material Specification

Housing	PP
Cable	UL 1007, AWG 24, 4 mm Stripped and Tinned
Nuts	PA66, M8, 1 pc Preassembled
Float	PP Foam
Potting	PU / Epoxy
Sealing Ring	Silicone

Operation View

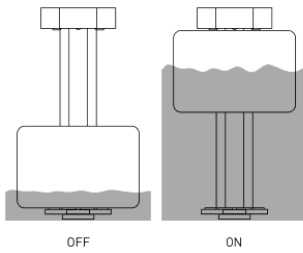

When mounted near ferromagnetic parts switching distance of RND 410-00006 may vary

Electromagnetical influences and magnetic fields may change the switching behaviour of the Level Sensor

Mounting

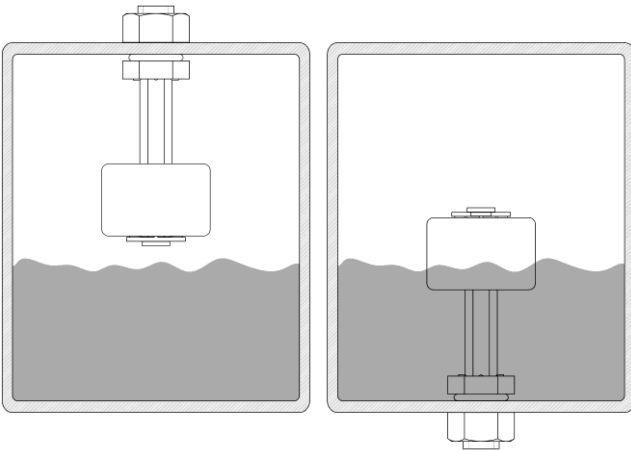

When mounted stem up, operating functions are reversed

Art Nr.
RND 410-00006