

Features

- Easy to install: fast and simple integration ensure stable performance in any application
- Waterproof, IP66 / IP68 protection
- Safe and reliable
- For use with outdoor lighting, sensor equipment, outdoor communication equipment & more

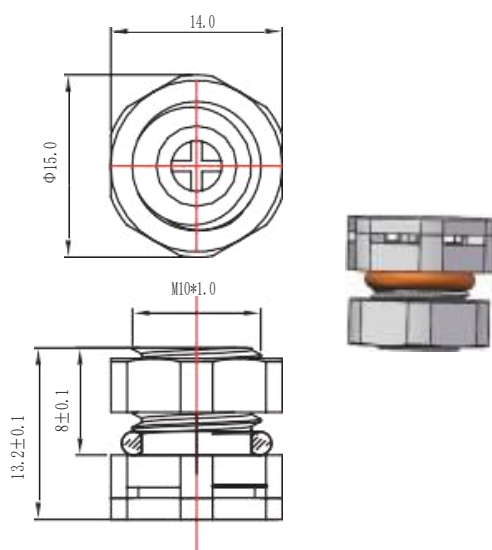

Specification

Air Permeability	250-2700 ml/min@0.07bar
Membrane Material	ePTFE
Membrane Characteristics	Oleophobic & Hydrophobic
Body Material	PA66+25% glass fiber
Colour	Black
Torque Wrench Size	14
O-ring Material	Silica gel 60H shore hardness A
Clamping Nut Material	PA66
Flammability Level	V0
Salt Resistance	10<0.1%
Antibacterial Level (GB/T 2423.16)	1 Level
Anti High & Low Temperature	-40°C~120°C
IP Level	IP66 / IP68
Traceability	With Independent Laser Serial No.
Recommended Torque	0.6±0.1N.m
Installation	Thread

Art. Nr.
RND 455-01102