

P-Clip DIN 3016, Stainless Steel RND cable

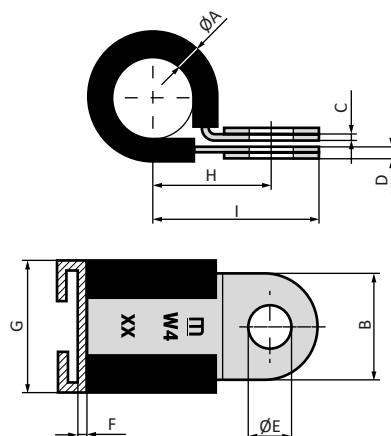

SPECIFICATION:

Material	W4 Stainless Steel AISI 304, lined with EPDM rubber
Feature	Reinforced screw holes at both ends
Corrosion specification	Salt spray test 240 hours (ASTM B-117)
Temperature resistance	(EPDM Rubber) -40°C to +120°C
To suit screw size	M6

Art. Nr.	Ø A	B ±0.3	C +0.2-0.1	D +0.2-0.1	Ø E +0.22-0	F ±0.35	G ±0.8	H +1/-0.2	I MAX
RND 475-00865	5 mm	15 mm	0.6 mm	1.6 mm	6.4 mm	1.5 mm	19 mm	13.7 mm	21.2 mm
RND 475-00866	6 mm	15 mm	0.6 mm	1.6 mm	6.4 mm	1.5 mm	19 mm	14.2 mm	21.7 mm
RND 475-00867	8 mm	15 mm	0.6 mm	1.6 mm	6.4 mm	1.5 mm	19 mm	15.2 mm	22.7 mm
RND 475-00868	9 mm	15 mm	0.6 mm	1.6 mm	6.4 mm	1.5 mm	19 mm	15.7 mm	23.2 mm
RND 475-00869	10 mm	15 mm	0.6 mm	1.6 mm	6.4 mm	1.5 mm	19 mm	16.2 mm	23.7 mm
RND 475-00870	11 mm	15 mm	0.6 mm	1.6 mm	6.4 mm	1.5 mm	19 mm	16.7 mm	24.2 mm
RND 475-00871	12 mm	15 mm	0.6 mm	1.6 mm	6.4 mm	1.5 mm	19 mm	17.2 mm	24.7 mm
RND 475-00872	13 mm	15 mm	0.6 mm	1.6 mm	6.4 mm	1.5 mm	19 mm	17.7 mm	25.2 mm
RND 475-00873	14 mm	15 mm	0.6 mm	1.6 mm	6.4 mm	1.5 mm	19 mm	18.2 mm	25.7 mm
RND 475-00874	15 mm	15 mm	0.6 mm	1.8 mm	6.4 mm	1.5 mm	19 mm	18.7 mm	26.2 mm
RND 475-00875	16 mm	15 mm	0.6 mm	1.8 mm	6.4 mm	1.5 mm	19 mm	19.2 mm	26.7 mm
RND 475-00876	17 mm	15 mm	0.6 mm	1.8 mm	6.4 mm	1.5 mm	19 mm	19.7 mm	27.2 mm
RND 475-00877	18 mm	15 mm	0.6 mm	1.8 mm	6.4 mm	1.5 mm	19 mm	20.2 mm	27.7 mm
RND 475-00878	19 mm	15 mm	0.6 mm	1.8 mm	6.4 mm	1.5 mm	19 mm	20.7 mm	28.2 mm
RND 475-00879	20 mm	15 mm	0.6 mm	1.8 mm	6.4 mm	1.5 mm	19 mm	21.2 mm	28.7 mm
RND 475-00880	21 mm	15 mm	0.6 mm	1.8 mm	6.4 mm	1.5 mm	19 mm	21.7 mm	29.2 mm
RND 475-00881	22 mm	15 mm	0.6 mm	1.8 mm	6.4 mm	1.5 mm	19 mm	22.2 mm	29.7 mm
RND 475-00882	23 mm	15 mm	0.6 mm	1.8 mm	6.4 mm	1.5 mm	19 mm	22.7 mm	30.2 mm
RND 475-00883	25 mm	15 mm	0.6 mm	1.8 mm	6.4 mm	1.5 mm	19 mm	23.7 mm	31.2 mm
RND 475-00884	26 mm	15 mm	0.6 mm	1.8 mm	6.4 mm	1.5 mm	19 mm	24.2 mm	31.7 mm
RND 475-00885	27 mm	15 mm	0.6 mm	1.8 mm	6.4 mm	1.5 mm	19 mm	24.7 mm	32.2 mm
RND 475-00886	28 mm	15 mm	0.6 mm	1.8 mm	6.4 mm	1.5 mm	19 mm	25.2 mm	32.7 mm
RND 475-00887	30 mm	15 mm	0.6 mm	1.8 mm	6.4 mm	1.5 mm	19 mm	26.2 mm	33.7 mm

P-Clip DIN 3016, Stainless Steel

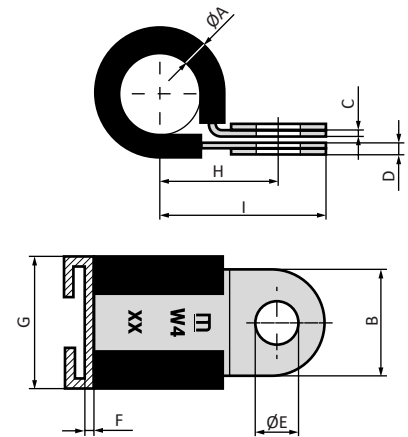

SPECIFICATION:

Material	W4 Stainless Steel AISI 304, lined with EPDM rubber
Feature	Reinforced screw holes at both ends
Corrosion specification	Salt spray test 240 hours (ASTM B-117)
Temperature resistance	(EPDM Rubber) -40°C to +120°C
To suit screw size	M6

Art. Nr.	Ø A	B ±0.3	C +0.2-0.1	D +0.2-0.1	Ø E +0.22-0	F ±0.35	G ±0.8	H +1/-0.2	I MAX
RND 475-00888	32 mm	15 mm	0.6 mm	1.8 mm	6.4 mm	1.5 mm	19 mm	27.2 mm	34.7 mm
RND 475-00889	33 mm	15 mm	0.6 mm	1.8 mm	6.4 mm	1.5 mm	19 mm	27.7 mm	35.2 mm
RND 475-00890	34 mm	15 mm	0.6 mm	1.8 mm	6.4 mm	1.5 mm	19 mm	28.2 mm	35.7 mm
RND 475-00891	35 mm	15 mm	0.6 mm	1.8 mm	6.4 mm	1.5 mm	19 mm	28.7 mm	36.2 mm
RND 475-00892	36 mm	15 mm	0.6 mm	1.8 mm	6.4 mm	1.5 mm	19 mm	29.2 mm	36.7 mm
RND 475-00893	37 mm	15 mm	0.6 mm	1.8 mm	6.4 mm	1.5 mm	19 mm	29.7 mm	37.2 mm
RND 475-00894	38 mm	15 mm	0.6 mm	1.8 mm	6.4 mm	1.5 mm	19 mm	30.2 mm	37.7 mm