



# TAOGLAS®



# Datasheet

## L1/L2 Surface Mount GNSS Front-End Module

**Part No:**  
TFM.100A

### Description

Surface mount GNSS front-end module covering L1/L2

### Features:

- Two-stage LNA providing >25 dB Gain across all bands
- Low Noise Figure: <3.25 dB in low bands and <3.0 dB in high bands
- Vin = +1.8 to +5.5 VDC
- Easy to integrate surface-mount
- Dimensions: 20 x 18 x 2.76 mm
- RoHS & Reach Compliant

<b>1.</b>	<b>Introduction</b>	<b>2</b>
<b>2.</b>	<b>Specification</b>	<b>3</b>
<b>3.</b>	<b>FEM Low Band Characteristics</b>	<b>4</b>
<b>4.</b>	<b>FEM High Band Characteristics</b>	<b>7</b>
<b>5.</b>	<b>Mechanical Drawing</b>	<b>10</b>
<b>6.</b>	<b>Eval Board Mechanical Drawing</b>	<b>11</b>
<b>7.</b>	<b>Module Integration</b>	<b>12</b>
<b>8.</b>	<b>Solder Recommendations</b>	<b>21</b>
<b>9.</b>	<b>Packaging</b>	<b>22</b>
<hr/>		
	<b>Changelog</b>	<b>23</b>

Taoglas makes no warranties based on the accuracy or completeness of the contents of this document and reserves the right to make changes to specifications and product descriptions at any time without notice. Taoglas reserves all rights to this document and the information contained herein. Reproduction, use or disclosure to third parties without express permission is strictly prohibited.



# 1. Introduction



The Taoglas TFM.100A is a surface-mount active electronics GNSS front-end which covers L1/L2 for multiband multi-constellation high-precision applications. The TFM.110A features a SAW/LNA/SAW/LNA topology in the signal path to prevent unwanted out-of-band interference from overdriving the GNSS LNAs or receiver. The SAW filters have been carefully selected and placed to provide excellent out-of-band rejection while also maintaining low noise figure.

Many currently available dual-band GNSS receivers require additional RF circuits between the antenna and the receiver to properly set the overall system noise figure. This requires additional development time for an otherwise simple module integration. Many organizations don't have the RF expertise to effectively design such a solution. The TFM.100A captures the required additional RF circuits in modular form, allowing the designer to simply place the TFM.100A between their GNSS antenna and GNSS receiver.

The TFM.100A offers > 25 dB gain across all applicable bands while maintaining a high P1dB of -24 dBm or better. Noise Figure is < 3.25 dB in the low bands and < 3.0 dB in the high bands. A wide input voltage of +1.8 to +5.5 VDC allows for easy integration in most GNSS systems.

Taoglas also offers the TFM.100B for L1+B1+G1/L5 applications.

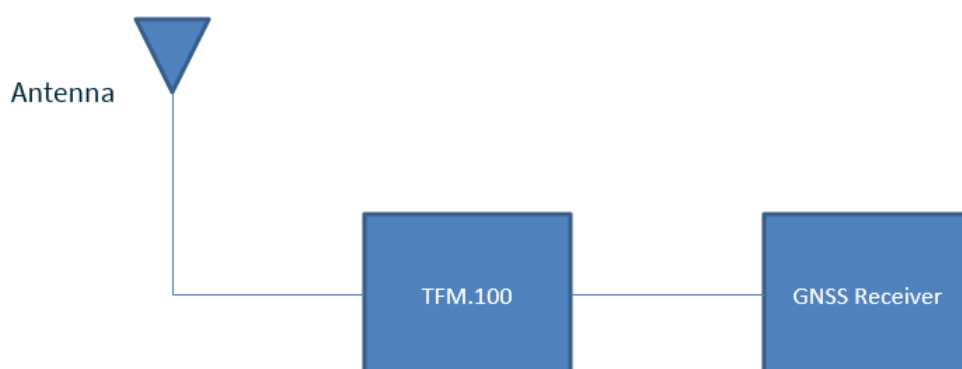

## 2. Specification

Electrical						
Frequency (MHz)	1197	1227	1249	1559	1575.42	1606
Noise Figure (dB)*	2.9	3.2	3.2	2.5	2.2	2.9
Gain (dB)	28	28	26	26	27	25
Group Delay (ns)	46	31	36	36	29	33
Input P1dB (dBm)	-23	-23	-21	-22	-22	-21
Input Return Loss (dB)	-19	-19	-10	-15	-15	-9
Output Return Loss	-6	-7	-6	-7	-8	-8
Vin	+1.8 to +5.5 VDC					
Typical Current (@1.8V)	7.5 – 9.0mA					

\*Note: Tested on evaluation board. Board losses removed.

Mechanical	
Height	2.76 mm max.
Planar Dimension	20 mm x 18 mm
Weight	2g

Environmental	
Temperature Range	-40°C to 85°C
RoHS Compliant	Yes
REACH Compliant	Yes

### 3. FEM Low Band Characteristics

#### 3.1 Low Band Input Return Loss

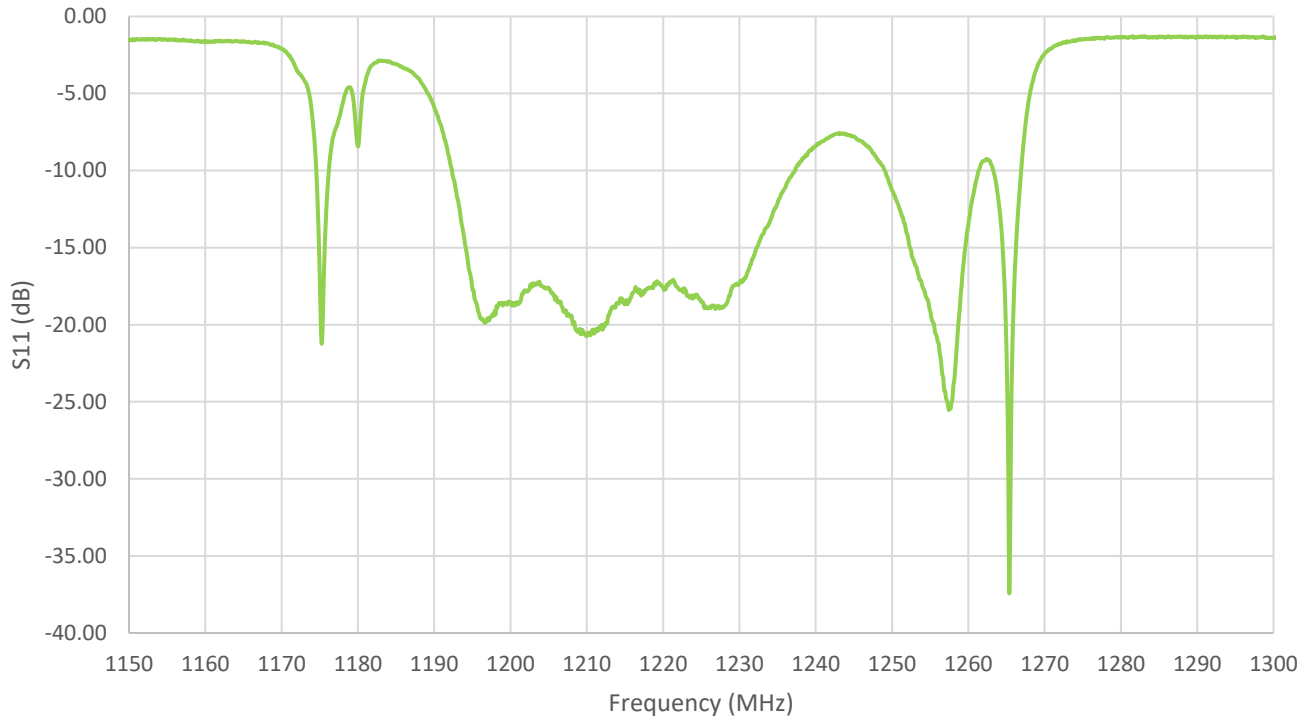

#### 3.2 Low Band Output Return Loss

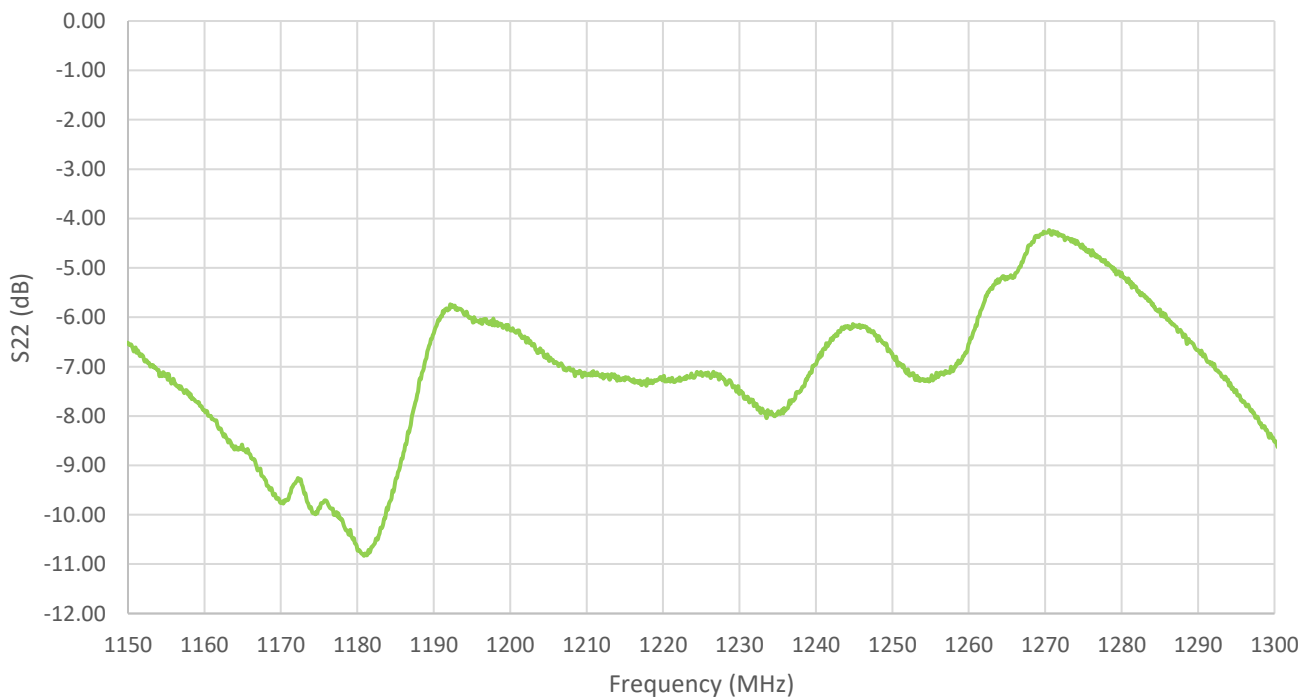

### 3.3 Low Band Noise Figure

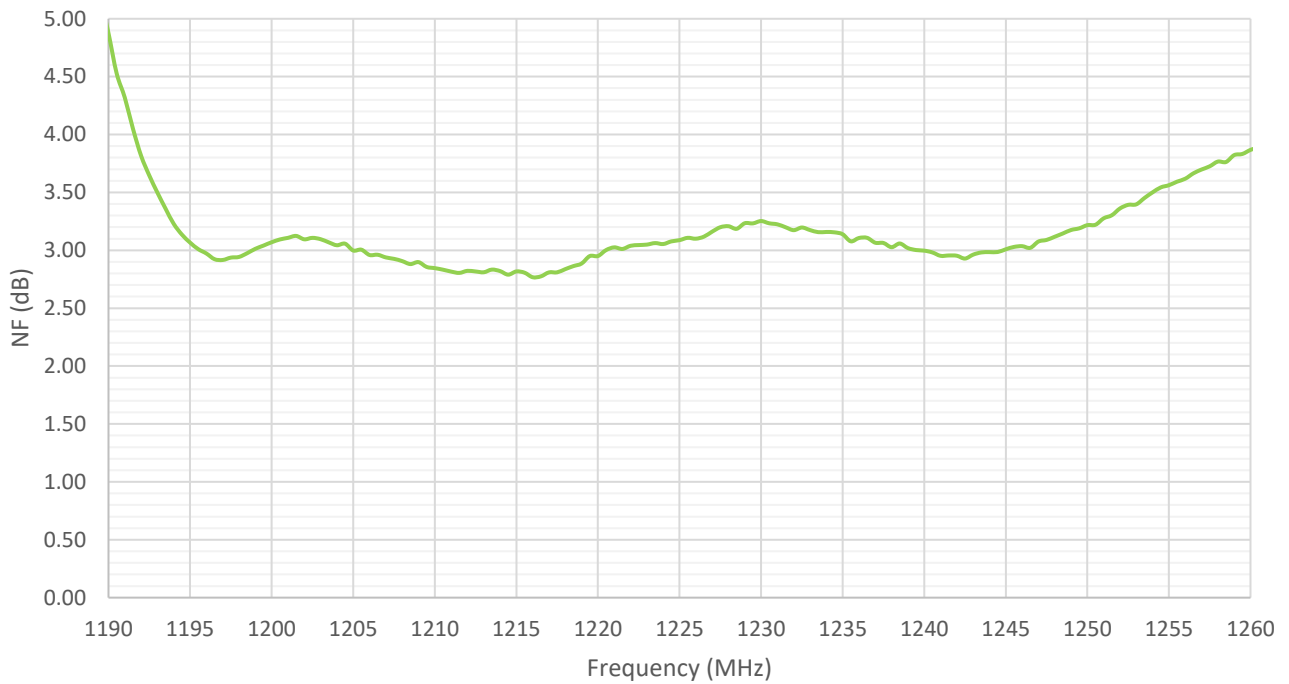

### 3.4 Low Band Gain

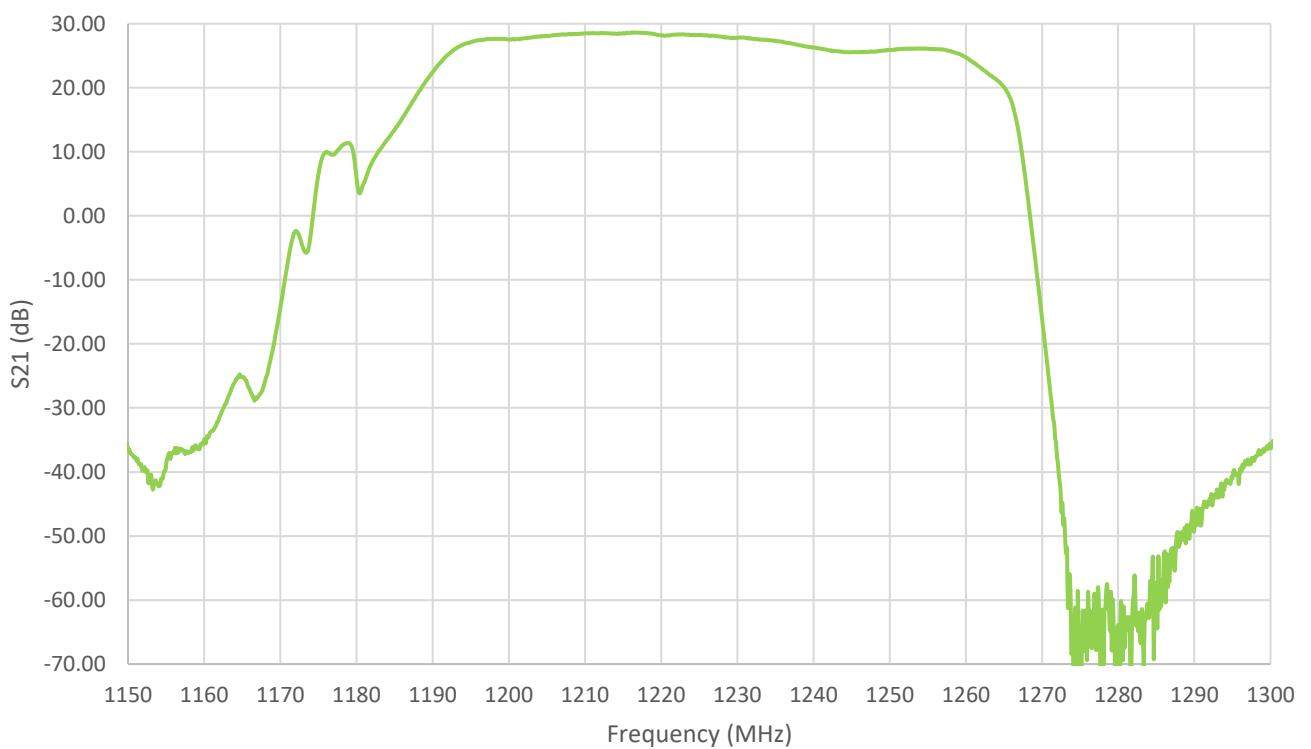

### 3.5 Low Band Gain and Attenuation

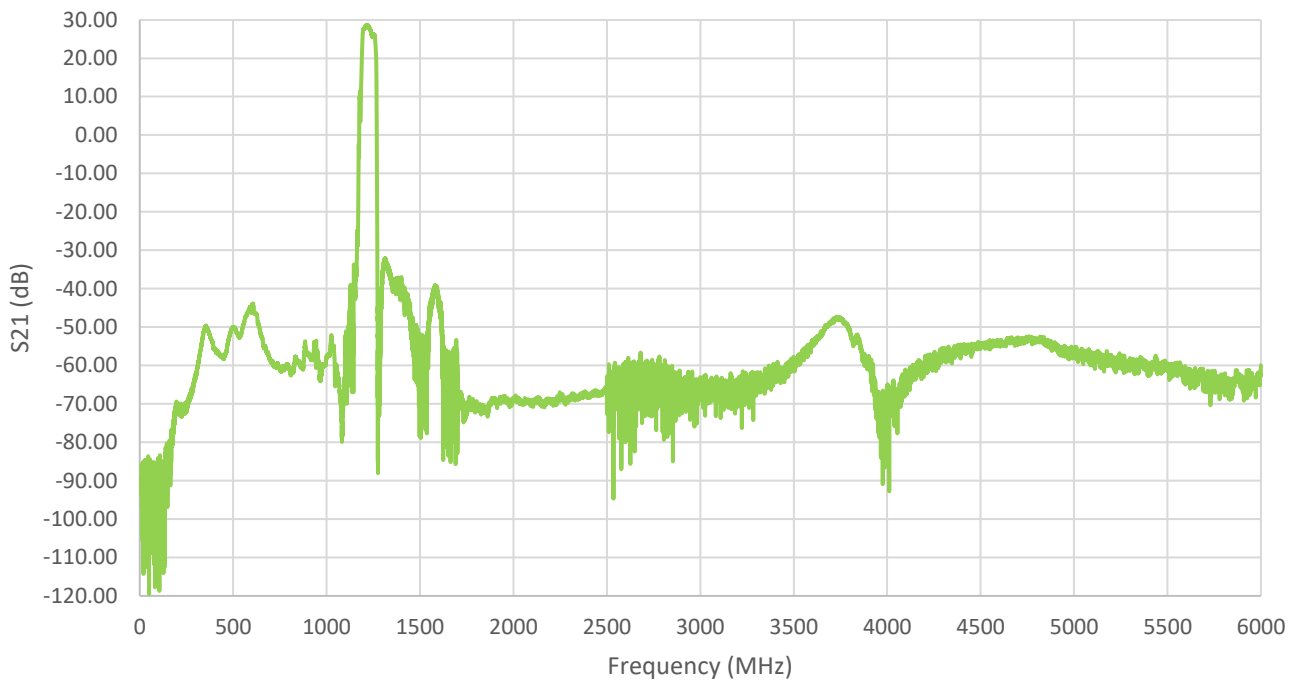

### 3.6 Low Band Group Delay

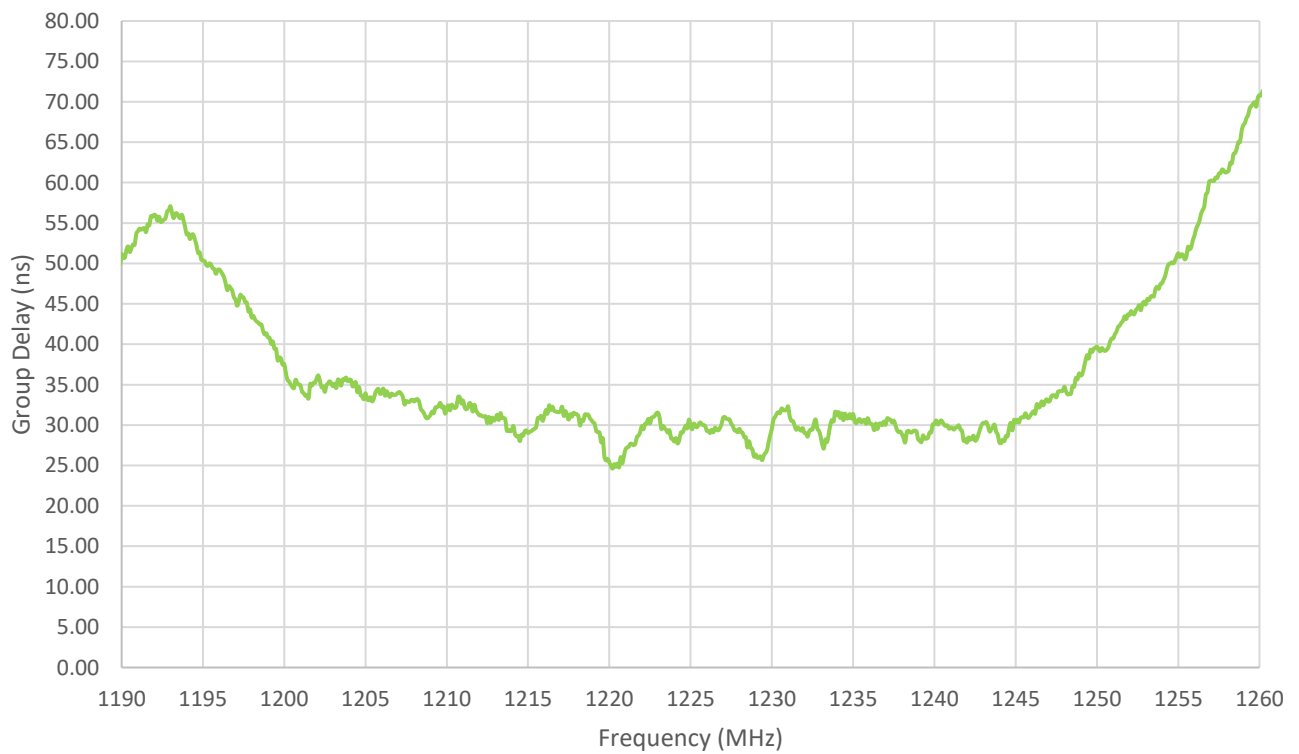

## 4. FEM High Band Characteristics

### 4.1 High Band Input Return Loss

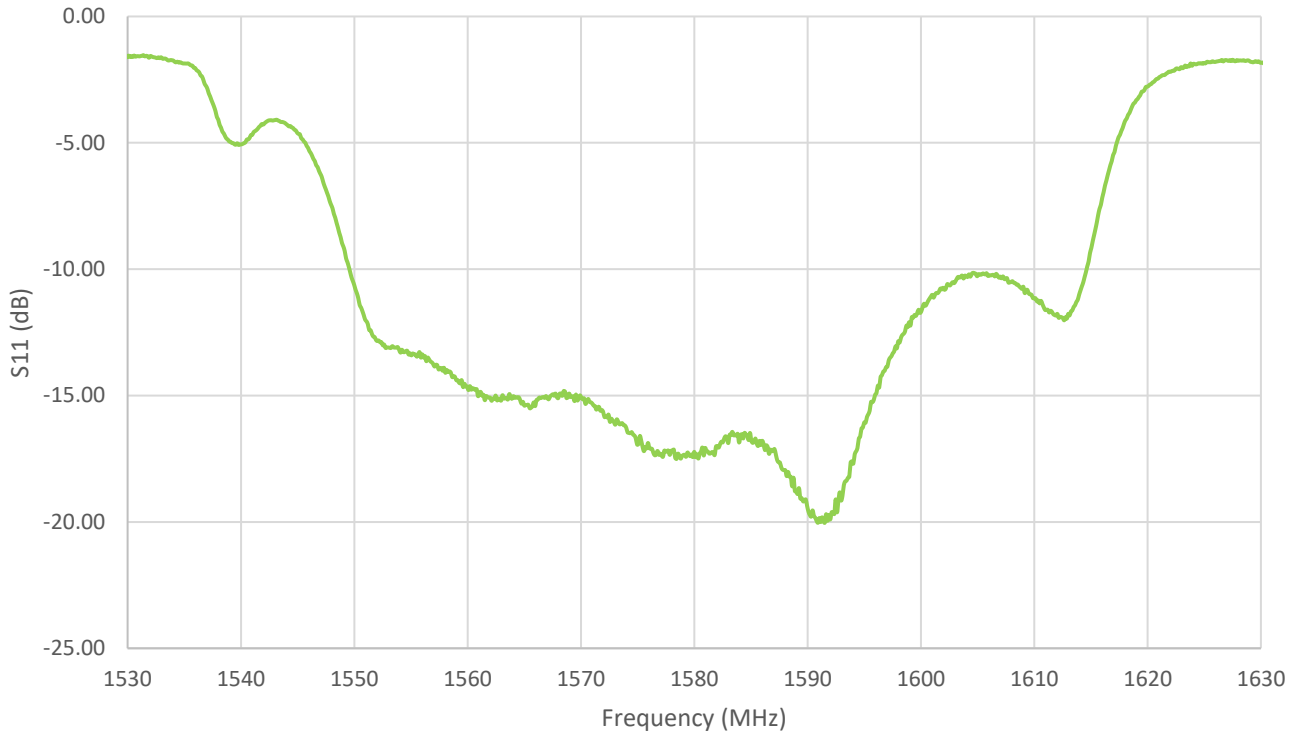

### 4.2 High Band Output Return Loss

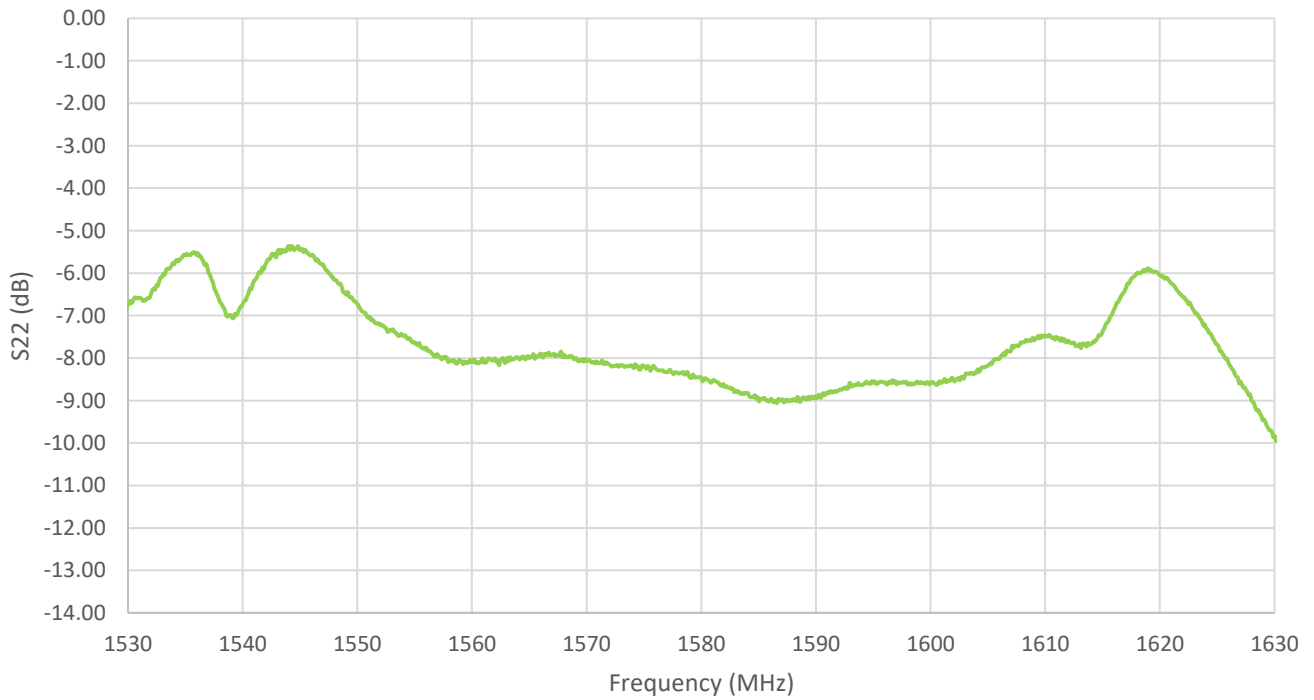



### 4.3 High Band Noise Figure

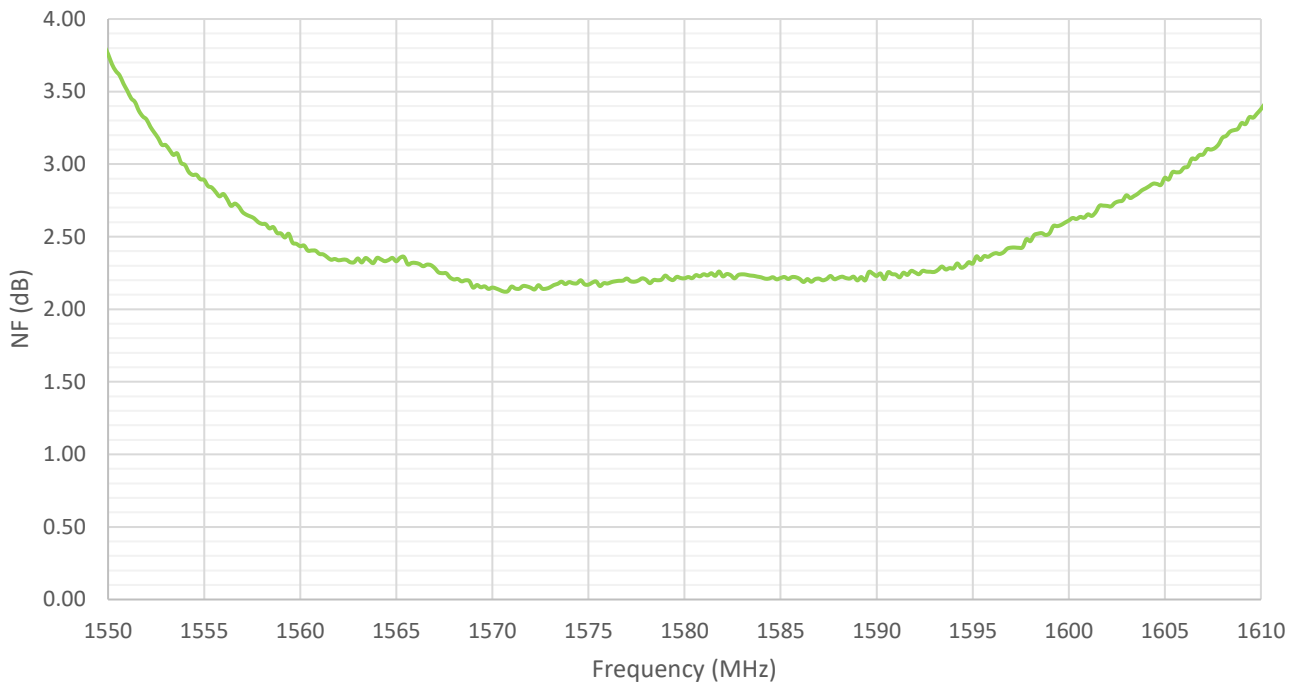

### 4.4 High Band Gain

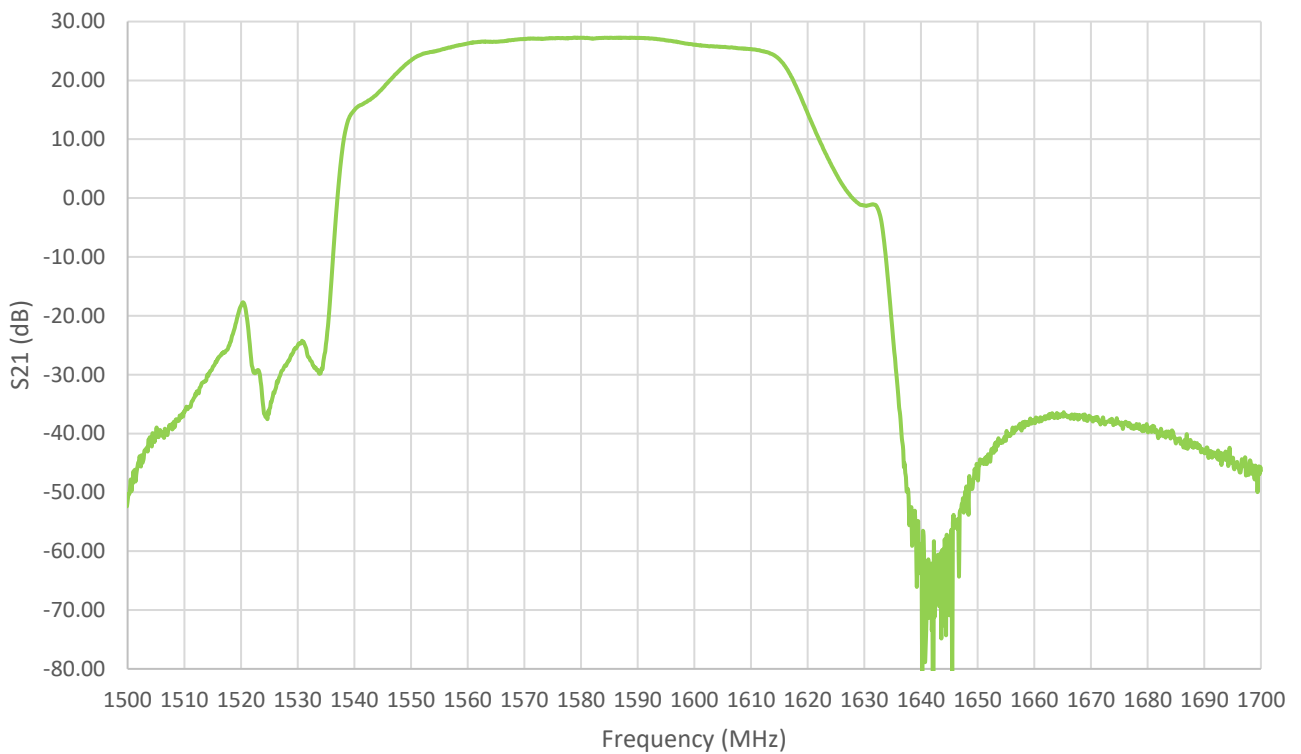

## 4.5 High Band Gain and Attenuation

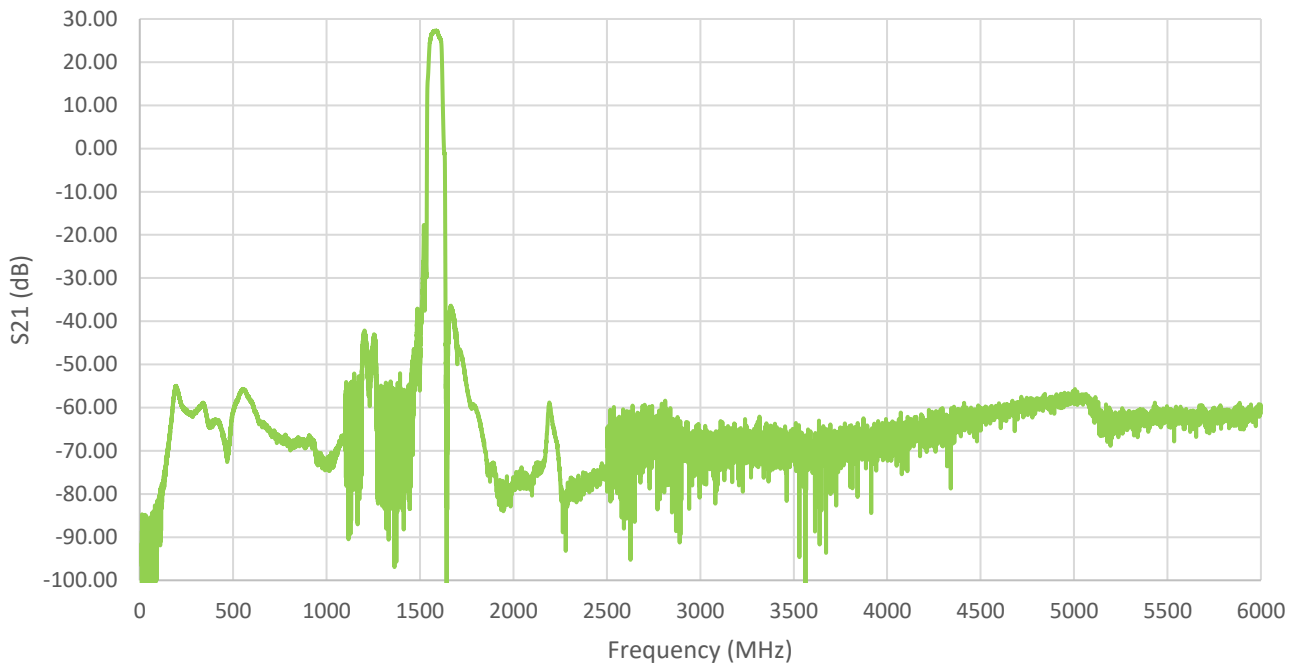

## 4.6 High Band Group Delay

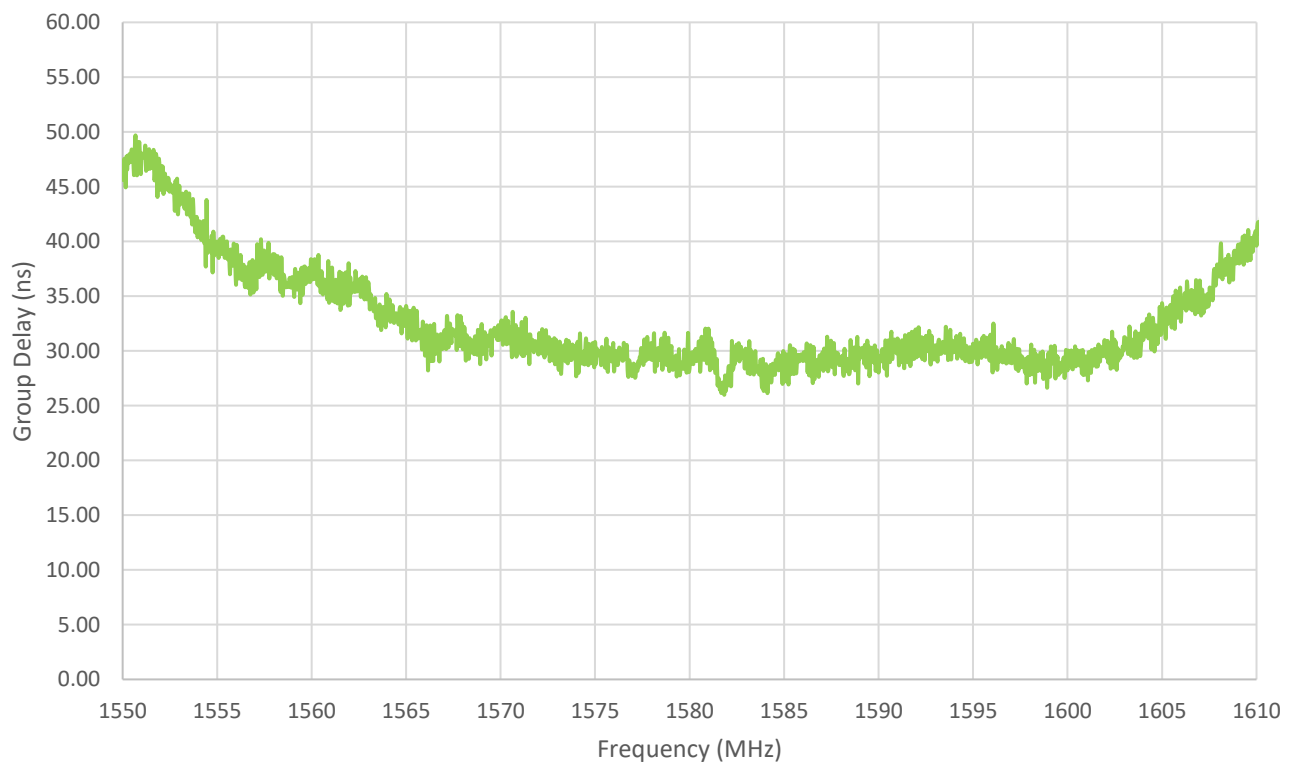

# 5. Mechanical Drawing

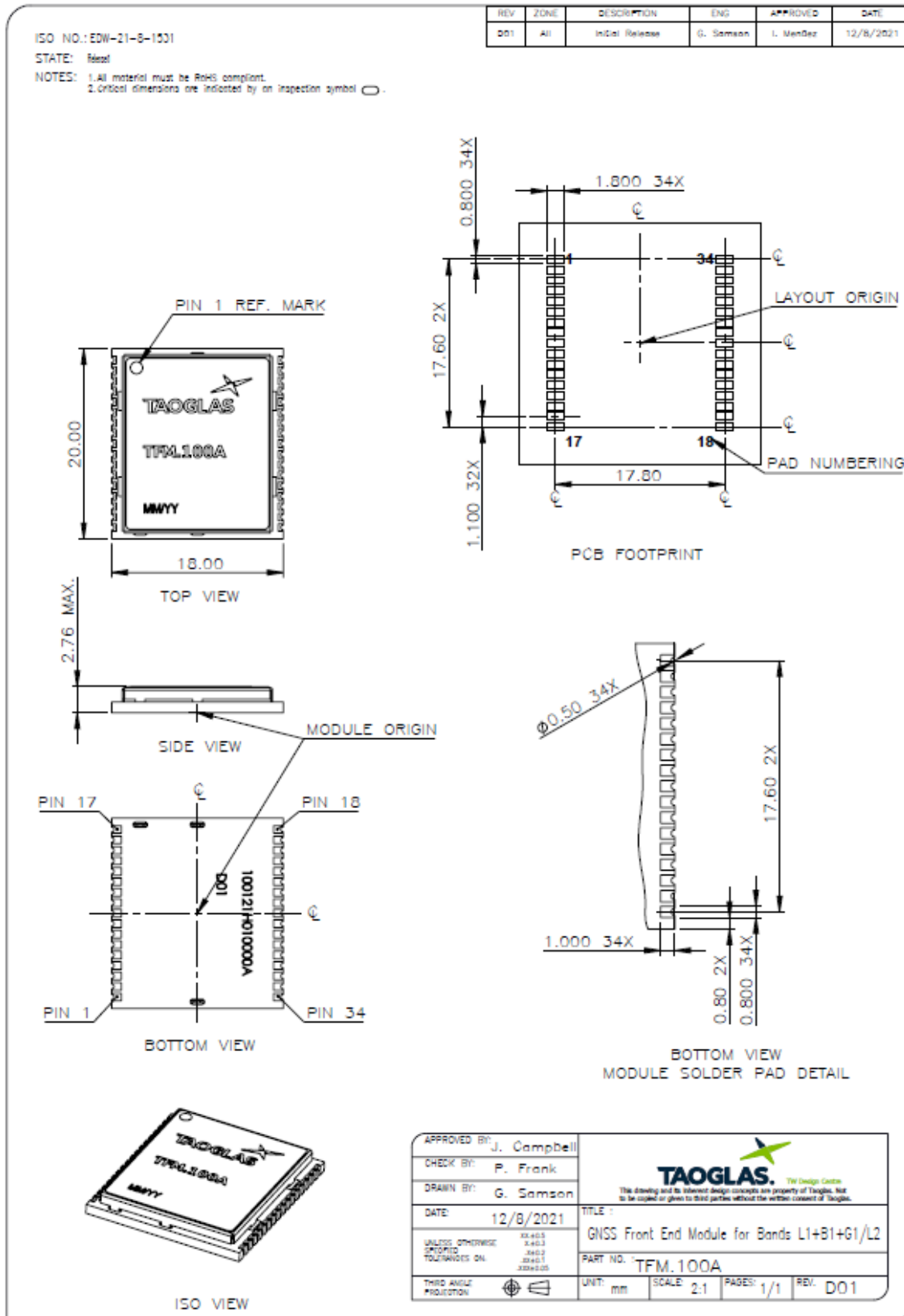

# 6. Eval Board Mechanical Drawing

ISO NO.: EDW-22-8-0100

STATE: Released

NOTES:

1. All material must be RoHS compliant.
2. Use this drawing together with the corresponding 3D CAD database file to fully describe the part.
3. Critical dimensions are indicated by an inspection symbol  $\square$ .

REV	ZONE	DESCRIPTION	ENG	APPROVED	DATE
D01	All	Initial Release	G. Samson	L. Mendez	1/27/2022

Name	Material	Designator	QTY
TFM100A GNSSE Front End Module	NA	U1	1
TFM100 GNSSE Evaluation PCB	FR4	NA	1
Connector, Header, Vert. 2 Position, 2.54 mm	Brass/PhosBr	J3	1
SMA Jack 50 Ohm, PCB Edge Mount	Brass	J1, J2, J4	3
Ceramic Capacitor, 1000pF, CDG/HPD, 0402	Ceramic	C1, C2, C7	3
TVS Diode, 5.5 VWM, 7.5VC WLL-2-3	NA	D2	1

APPROVED BY: P. Frank	<p><b>TAOGLAS</b> <small>TW Design Centre</small></p> <p><small>The drawing and its inherent design concepts are property of Taoglas, not to be copied or given to third parties without the written consent of Taoglas.</small></p>
CHECK BY: J. Campbell	
DRAWN BY: G. Samson	
DATE: 1/27/2022	
UNLESS OTHERWISE SPECIFIED TOLERANCES IN: 3X±0.5, 3X±0.3, 3X±0.2, 3X±0.1, 3X±0.05	
THIRD ANGLE PROJECTION	<p>TITLE: GNSSE Front End Module Evaluation Board L1+B1+G1/L2</p> <p>PART NO.: TFM100A</p> <p>UNIT: mm SCALE: 1:1 PAGES: 1/1 REV: D01</p>

## 7. Module Integration

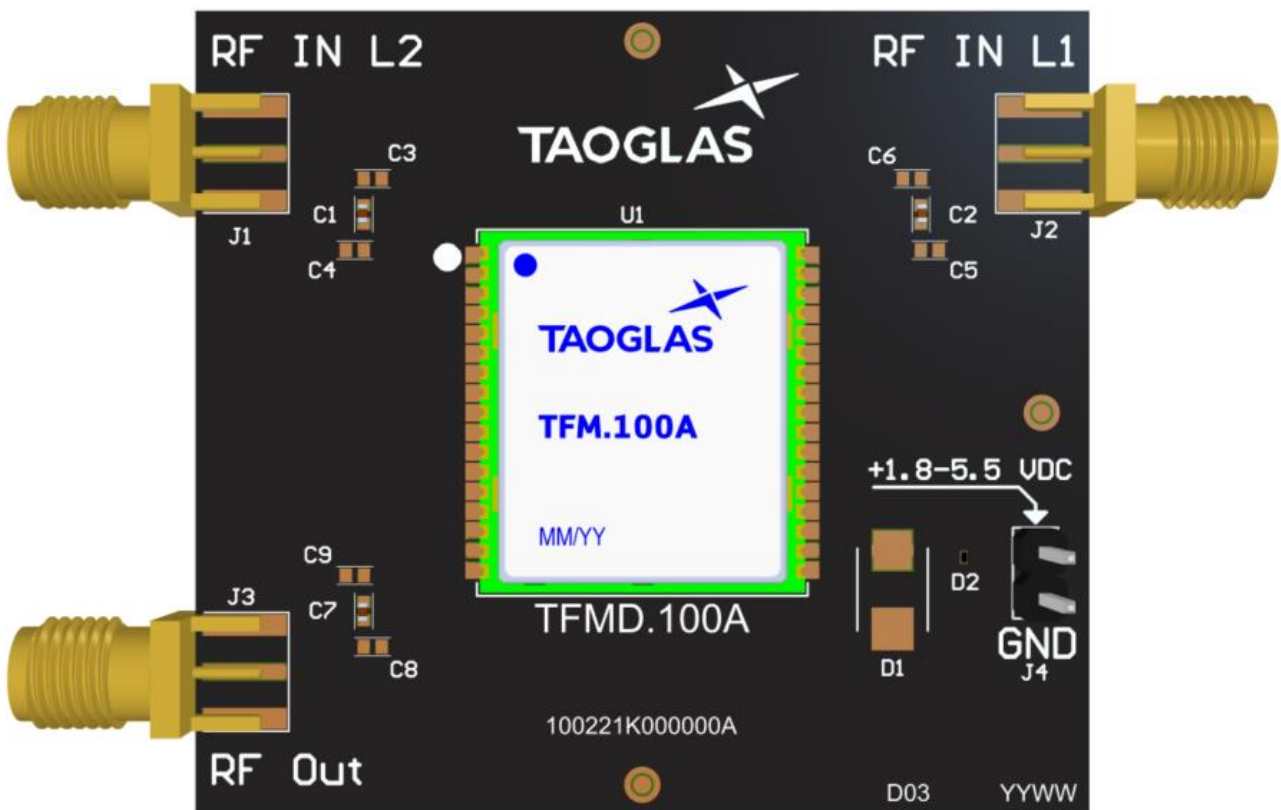
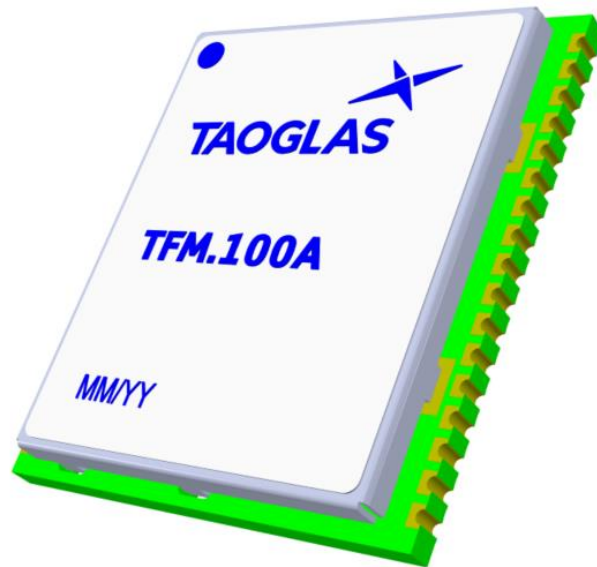

## 7.1 Schematic Symbol and Pin Definitions

The circuit symbol for the TFM.100A is shown below. The front-end module has 34 pins as indicated below.

Pin	Description
1, 3-15, 17-18, 20-32, 34	Ground
2	L2 Input
16	Signal Output
19	Voltage Input
33	L1 Input

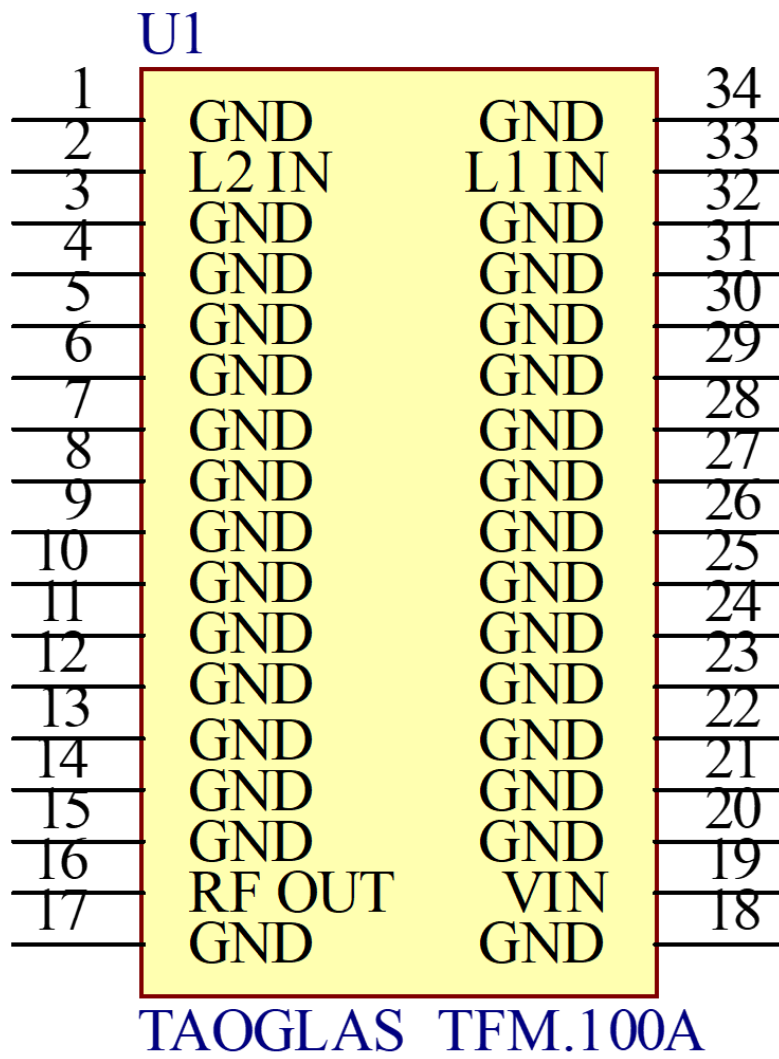

## 7.2 Module Integration

The TFM.100A should be placed as close to the signal input and output as possible to shorten the length of the transmission lines. The RF IN/OUT traces must maintain a 50 Ohm transmission line. A Pi Matching Network is recommended for the RF IN transmission lines, the values and components for the matching circuit will depend on the tuning needed. Ground vias should be placed beside each ground pad and the DC Voltage input should be between +1.8 & +5.5 VDC. It's recommended that the DC Voltage input should be coupled with a 100pF Capacitor and an ESD Diode.



Top Side w/o Solder Mask

### 7.3 PCB Clearance

The footprint and clearance on the PCB must comply with the front-end module's specification. The PCB layout shown in the diagram below demonstrates the TFM.100A clearance area for Pin 16 (RF OUT Pad) & Pin 33 (L1 IN Pad). This clearance also applies to Pin 2 (L2 IN Pad). The copper keep out area only applies to the same layer the TFM.100A was placed.

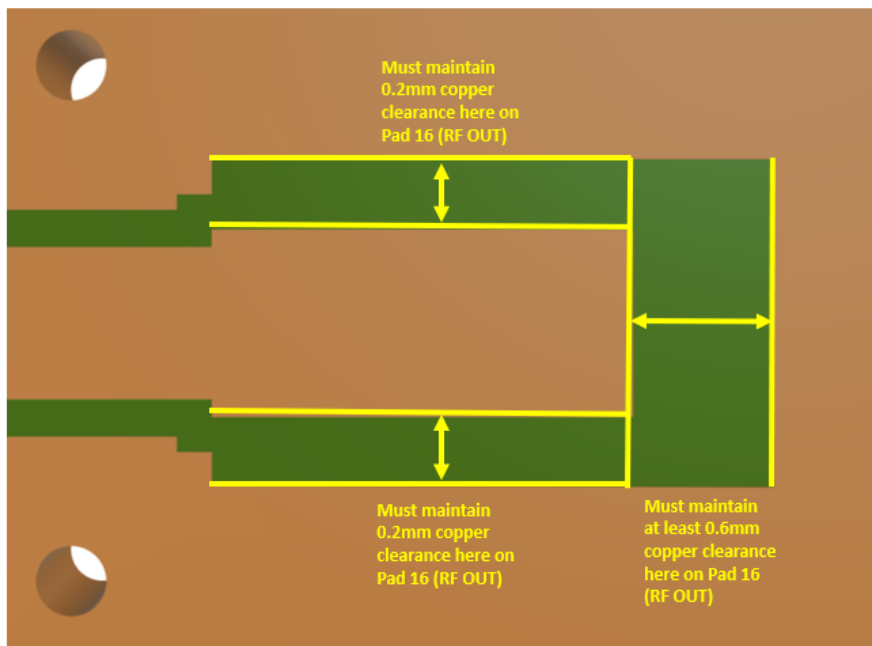

Pin 16 (RF OUT Pad)

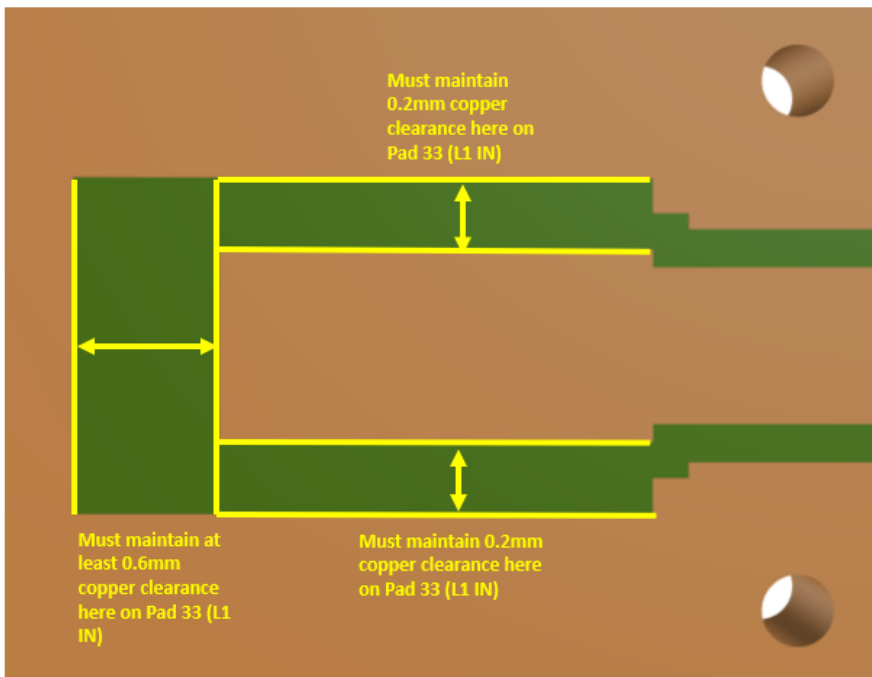

Pin 33 (L1 IN Pad)



## 7.4 PCB Layout

The footprint and clearance on the PCB must comply with the module specification. The PCB layout shown in the diagram below demonstrates the module footprint.

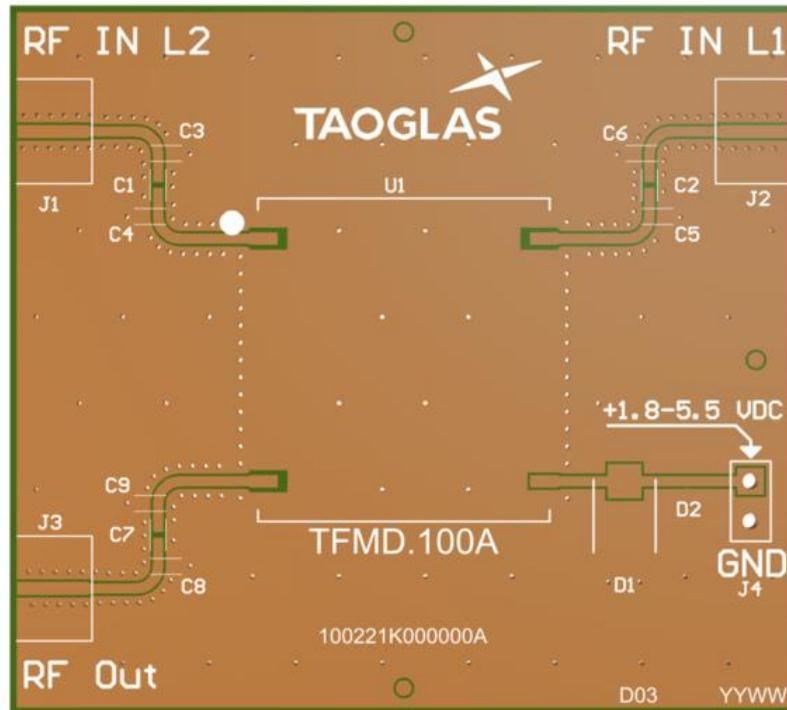

Topside

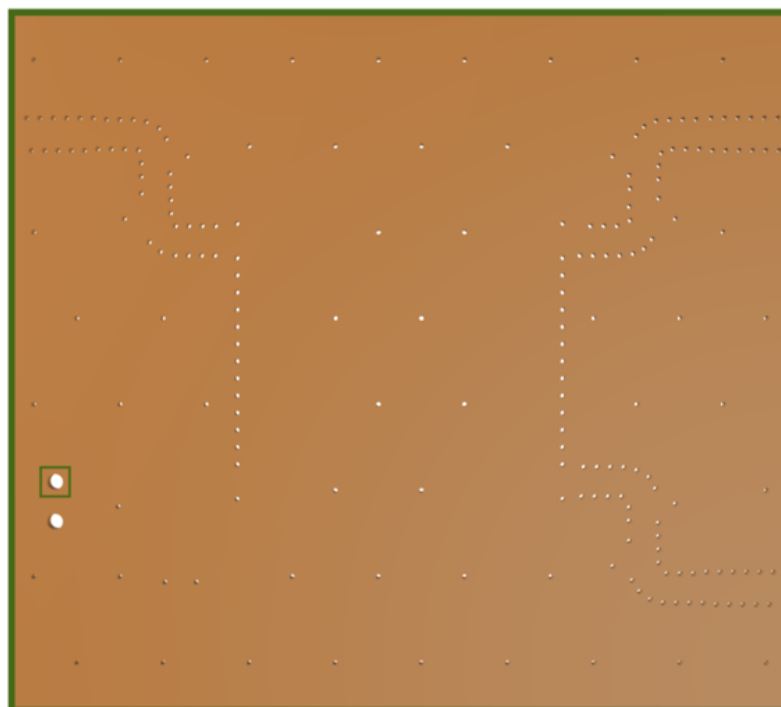

Bottom Side

7.5 Evaluation Board

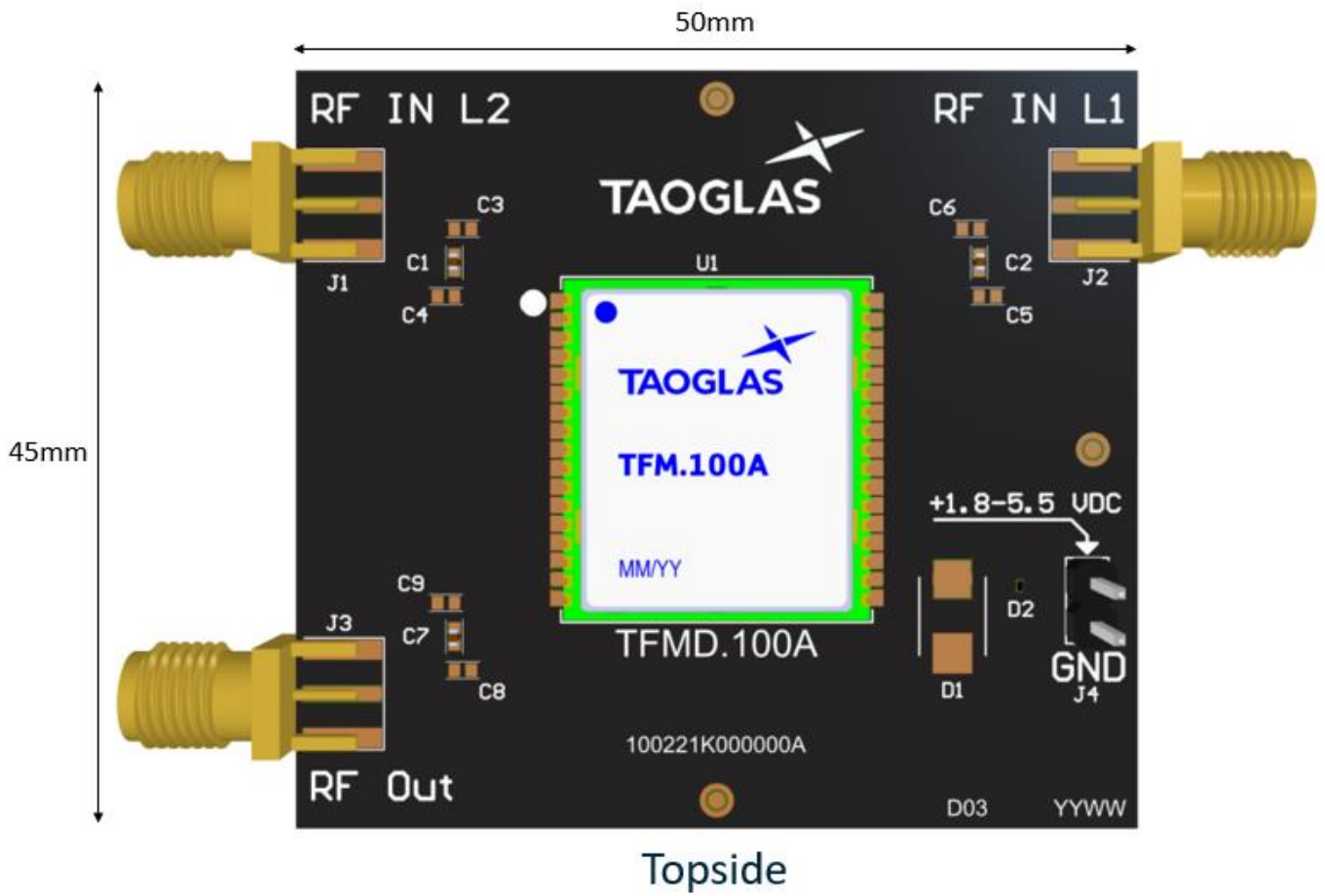

7.6 Demonstration Board

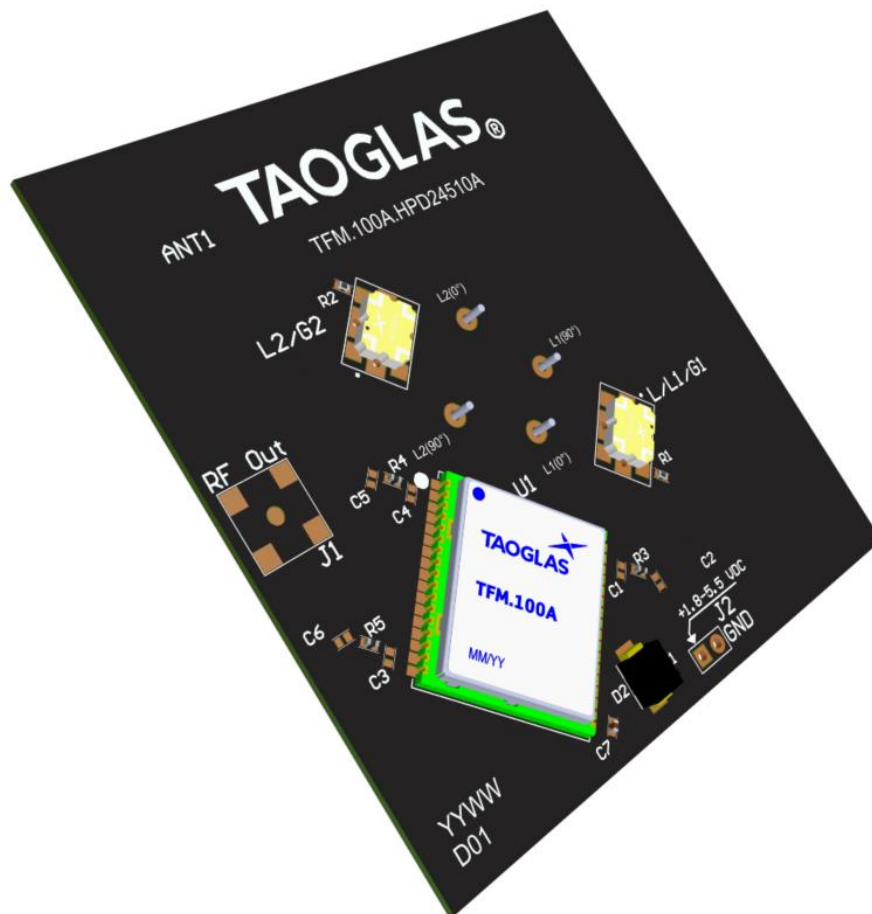

## 7.7 Demonstration Board Layout

The footprint and clearance on the PCB must comply with the module specification. The PCB layout shown in the diagram below demonstrates the module footprint.



Topside

7.8 Demonstration Board

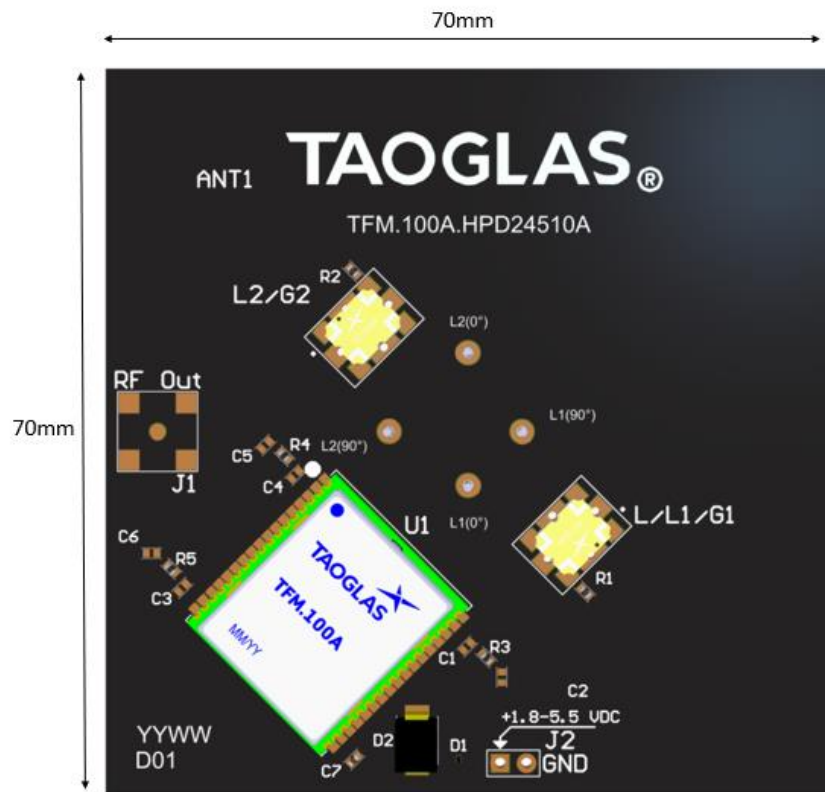

Topside

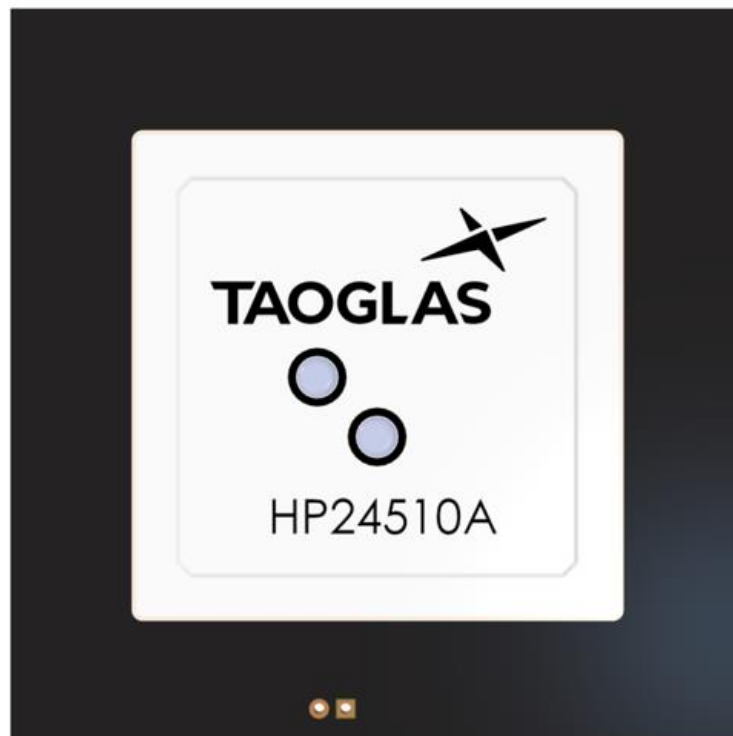

Bottom Side

## 8. Solder Recommendations

The TFM.100A can be assembled by following the recommended soldering temperatures are as follows:

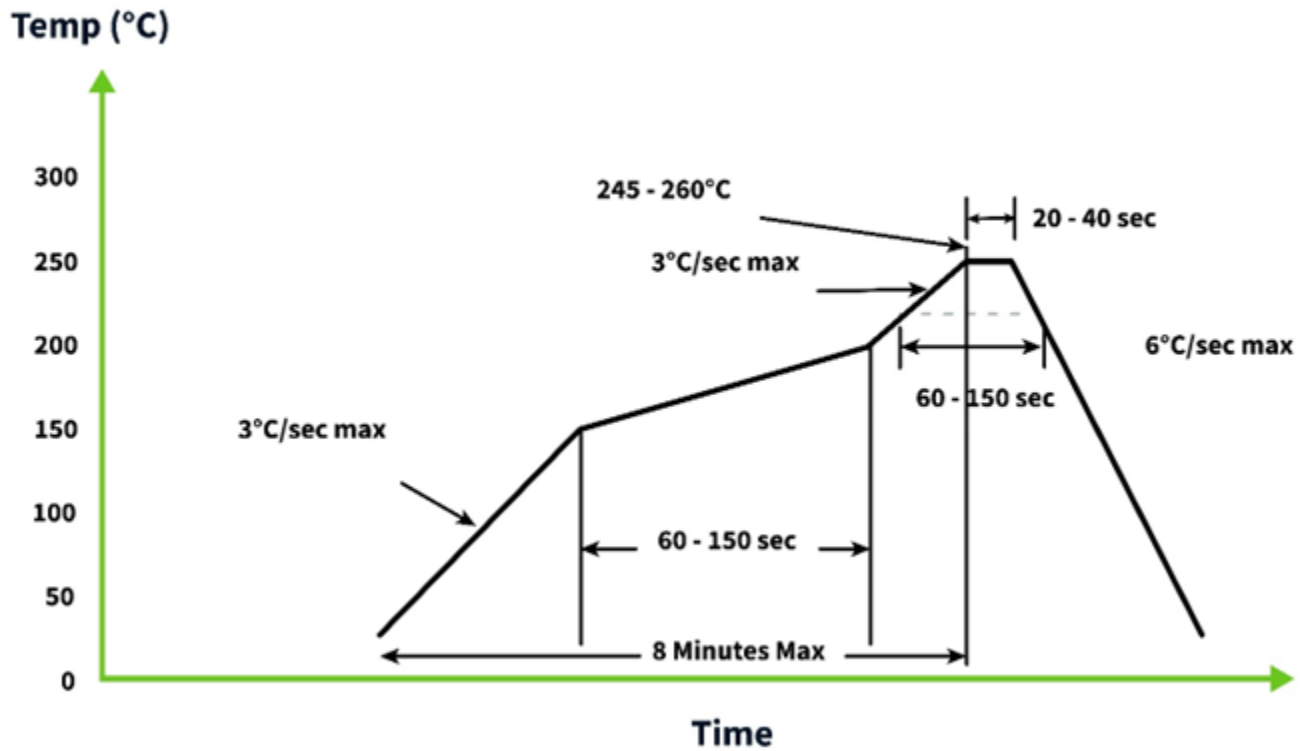

Smaller components are typically mounted on the first pass, however, we do advise mounting the TFM.100A when placing larger components on the board during subsequent reflows.

## 9. Packaging

600 PCS / Reel  
SPQ Label



600 PCS / Vacuum bag  
2 PCS / 3g Desiccant  
1 PCS / Humidity test paper  
SPQ Label

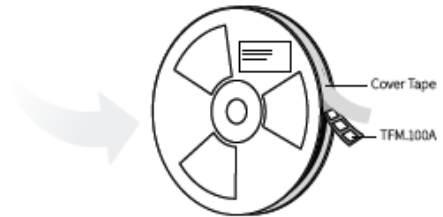

Caution Label  
Product Label  
SPQ Label



1 PCS / Box  
Box(mm): 350x340x67  
Weight (Kg): 2  
SPQ Label

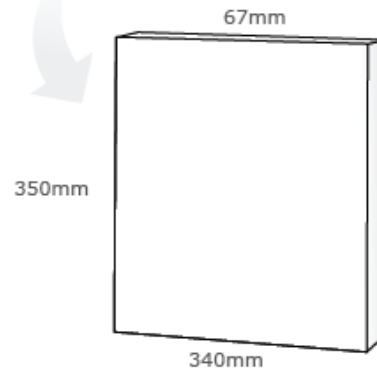

2400 PCS/ Carton  
Carton(mm): 370x360x275  
Weight (Kg): 8.8  
Carton Label

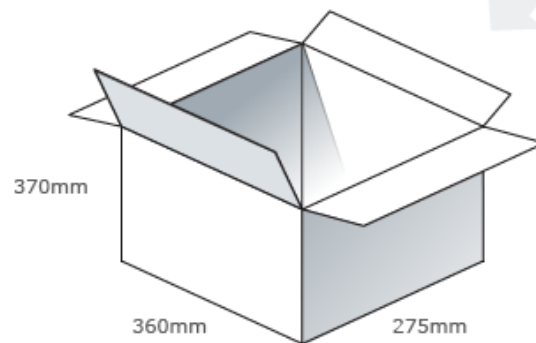

Changelog for the datasheet

**SPE-23-8-124 – TFM.100A**

**Revision: B (Current Version)**

Date:	2023-09-04
Notes:	Updated solder reflow recommendations and electrical specification table
Author:	Cesar Sousa

**Previous Revisions**

**Revision: A (Original First Release)**

Date:	2023-05-08
Notes:	Initial Release
Author:	Gary West





[www.taoglas.com](http://www.taoglas.com)

