

Shockwave

Part No:
TLS.01.305111

Description:

Shockwave 600-6000MHz Permanent Mount External Antenna with 3m CFD-200 SMA(M)

Features:

Applicable for 5G/4G, Cat M1 & NB-IoT bands
Over 45% efficiency and 2.2 dBi gain
Mechanically robust for indoor/outdoor applications
Height: 79.45mm (3.13"); Diameter: 42mm (1.65")
IP67 and IP69K Waterproof
IK10 Rated Enclosure
Cable: Low loss CFD-200 cable, 3 meters
Connector: SMA(M)
RoHS & Reach Compliant

1. Introduction	3
2. Specifications	4
3. Antenna Characteristics	6
4. Radiation Patterns	8
5. Mechanical Drawing	18
6. Installation Guidelines	19
7. Packaging	20
<hr/>	
8. Application Note	21
<hr/>	
Changelog	23

Taoglas makes no warranties based on the accuracy or completeness of the contents of this document and reserves the right to make changes to specifications and product descriptions at any time without notice. Taoglas reserves all rights to this document and the information contained herein. Reproduction, use or disclosure to third parties without express permission is strictly prohibited.



1. Introduction



The Shockwave TLS.01.305111 is a permanent mount, waterproof, external 5G/4G cellular wideband antenna operating at 600-6000MHz with an N type male connector. It has been designed to be used on a Ground Plane. It can be used in mobile and fixed applications for 4G LTE wireless such as:

- Public safety
- HD Video Streaming
- Utilities and Smart Cities
- Fleet Management
- Agricultural
- Industrial

This antenna has superior performance over wide-bands compared to traditional whip antennas. Up to 77% efficiency and with a minimum 2.2dBi peak gain over all cellular bands result when mounted on a 30x30 cm ground plane. Stable radiation patterns over low angles provides consistent gain in the horizontal plane, meaning that it is especially suitable for cellular applications.

A unique indent tab on the base of the antenna allows a wrench to be used to solidly lock the antenna on top of its mounting location while tightening up the nut beneath the metal panel. Waterproof O-rings around the bottom base prevent water from leaking under the antenna.

The TLS.01 antenna is IP67 waterproof and IP69K resistant against high pressure water jets in commercial cleaning environments, which makes the antenna ideal for 5G/4G applications either in indoor or in harsh outdoor environments. For more information contact your regional Taoglas customer support team.

2. Specifications

Electrical								
Band	Frequency (MHz)	Efficiency (%)	Average Gain (dB)	Peak Gain (dBi)	Impedance	Max Input Power	Polarization	Radiation Pattern
5GNR/4G Band 71	617~698	43	-3.2	-1	50 Ω	100W	Vertical	Omni-Directional
4G/3G Band 12,13,14,17,28,29	698~806	57.7	-0.2	3.1				
4G/3G/NB-IoT/Cat M Band 5,8,18,19,20,26,27	824~960	71.4	-0.7	3.2				
5GNR/4G Band 21,32,74,75,76	1427~1518	56.8	-1.4	2.9				
4G/3G Band 1,2,3,4,9,23,25,35,39,66	1710~2200	45.9	-1.8	2.7				
4G/3G Band 7,38,41	2490~2690	42.9	-2	3.4				
5GNR/4G Band 22,42,48,77,78,79	3300~5000	26.8	-4.1	2.5				
LTE5200/ Wi-Fi 5800	5150~5925	8.9	-3.4	5.3				

*Measured on 30*30cm ground plane

Mechanical	
Dimension (mm)	Height: 79.45mm(3.13") ; Diameter : 42mm(1.65")
Connector	SMA(M)ST
Cable	3m CFD-200
Housing Material	UV Resistant ABS
Base Material	Nickel Plated Zinc Alloy
Weight (g)	270
Rec. Torque for Mounting	4.018 N·m
Max. Torque for Mounting	9.8 N·m
Environmental	
Waterproof Rating	IP67 and IP69K
Operation Temperature	-40°C to 85°C
Humidity	Non-condensing 65°C 95% RH
Housing Rating	IK10

5G/4G Bands			
Band Number	5G NR / FR1 / LTE / LTE-Advanced / WCDMA / HSPA / HSPA+ / TD-SCDMA / Cat M / NB-IoT		
	Uplink	Downlink	Covered
1	UL: 1920 to 1980	DL: 2110 to 2170	✓
2	UL: 1850 to 1910	DL: 1930 to 1990	✓
3	UL: 1710 to 1785	DL: 1805 to 1880	✓
4	UL: 1710 to 1755	DL: 2110 to 2155	✓
5	UL: 824 to 849	DL: 869 to 894	✓
7	UL: 2500 to 2570	DL: 2620 to 2690	✓
8	UL: 880 to 915	DL: 925 to 960	✓
9	UL: 1749.9 to 1784.9	DL: 1844.9 to 1879.9	✓
11	UL: 1427.9 to 1447.9	DL: 1475.9 to 1495.9	✓
12	UL: 699 to 716	DL: 729 to 746	✓
13	UL: 777 to 787	DL: 746 to 756	✓
14	UL: 788 to 798	DL: 758 to 768	✓
17	UL: 704 to 716	DL: 734 to 746	✓
18	UL: 815 to 830	DL: 860 to 875	✓
19	UL: 830 to 845	DL: 875 to 890	✓
20	UL: 832 to 862	DL: 791 to 821	✓
21	UL: 1447.9 to 1462.9	DL: 1495.9 to 1510.9	✓
22	UL: 3410 to 3490	DL: 3510 to 3590	✓
23	UL: 2000 to 2020	DL: 2180 to 2200	✓
24	UL: 1625.5 to 1660.5	DL: 1525 to 1559	✓
25	UL: 1850 to 1915	DL: 1930 to 1995	✓
26	UL: 814 to 849	DL: 859 to 894	✓
27	UL: 807 to 824	DL: 852 to 869	✓
28	UL: 703 to 748	DL: 758 to 803	✓
29	UL: -	DL: 717 to 728	✓
30	UL: 2305 to 2315	DL: 2350 to 2360	✓
31	UL: 452.5 to 457.5	DL: 462.5 to 467.5	✗
32	UL: -	DL: 1452 - 1496	✓
35		1850 to 1910	✓
38		2570 to 2620	✓
39		1880 to 1920	✓
40		2300 to 2400	✓
41		2496 to 2690	✓
42		3400 to 3600	✓
43		3600 to 3800	✓
48		3550 to 3700	✓
66	UL: 1710-1780	DL: 2110-2200	✓
71		617 to 698	✓
74/75/76		1427 to 1518	✓
77		3300 to 4200	✓
78		3300 to 3800	✓
79		4400 to 5000	✓

3. Antenna Characteristics

3.1 Return Loss

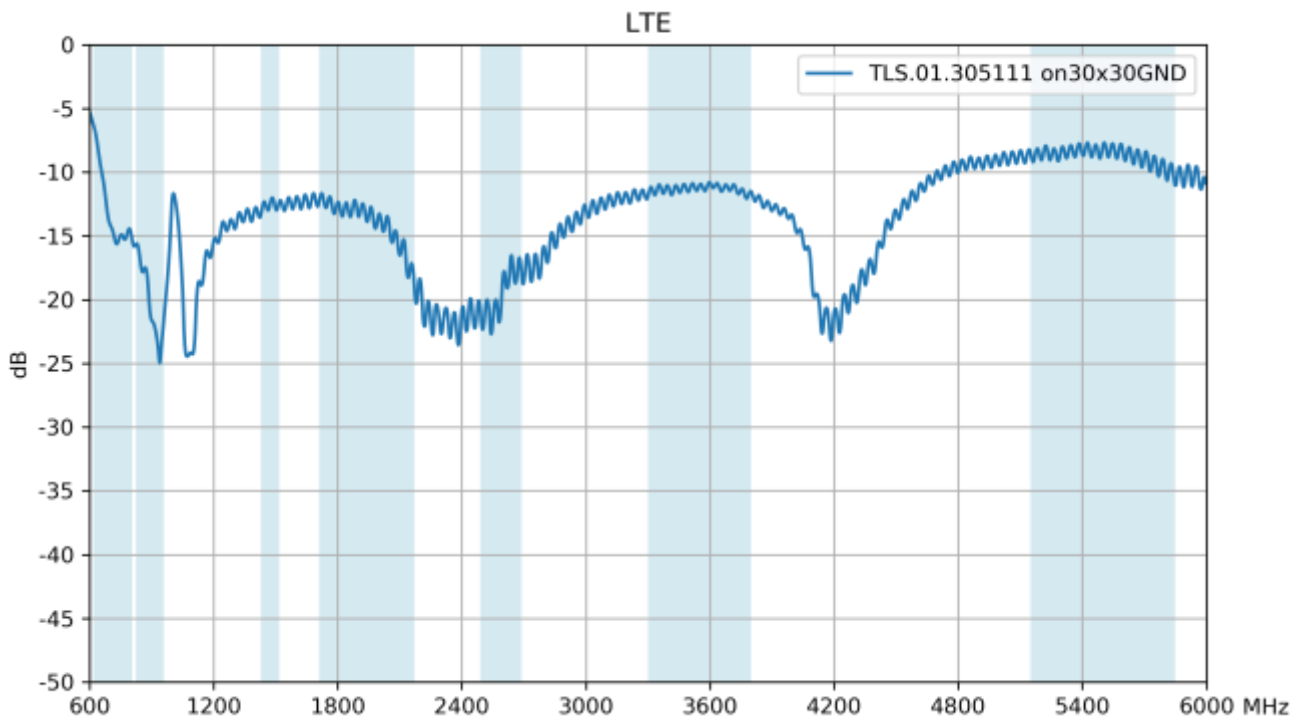

3.2 VSWR

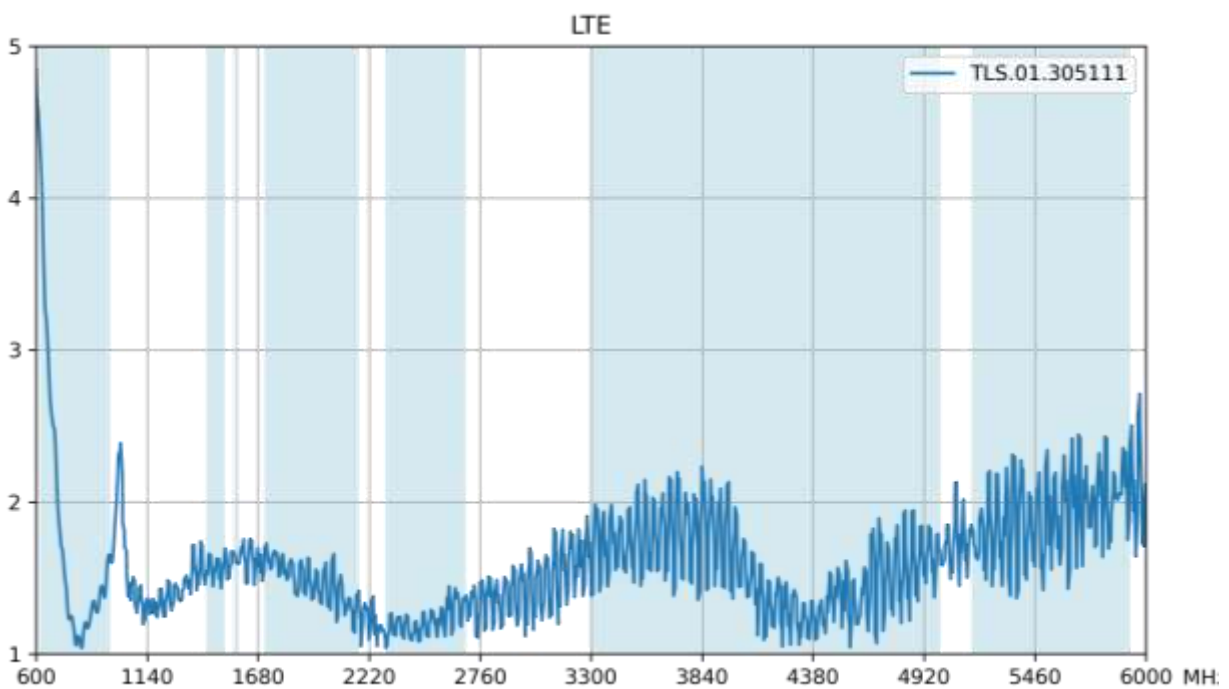

3.3 Efficiency

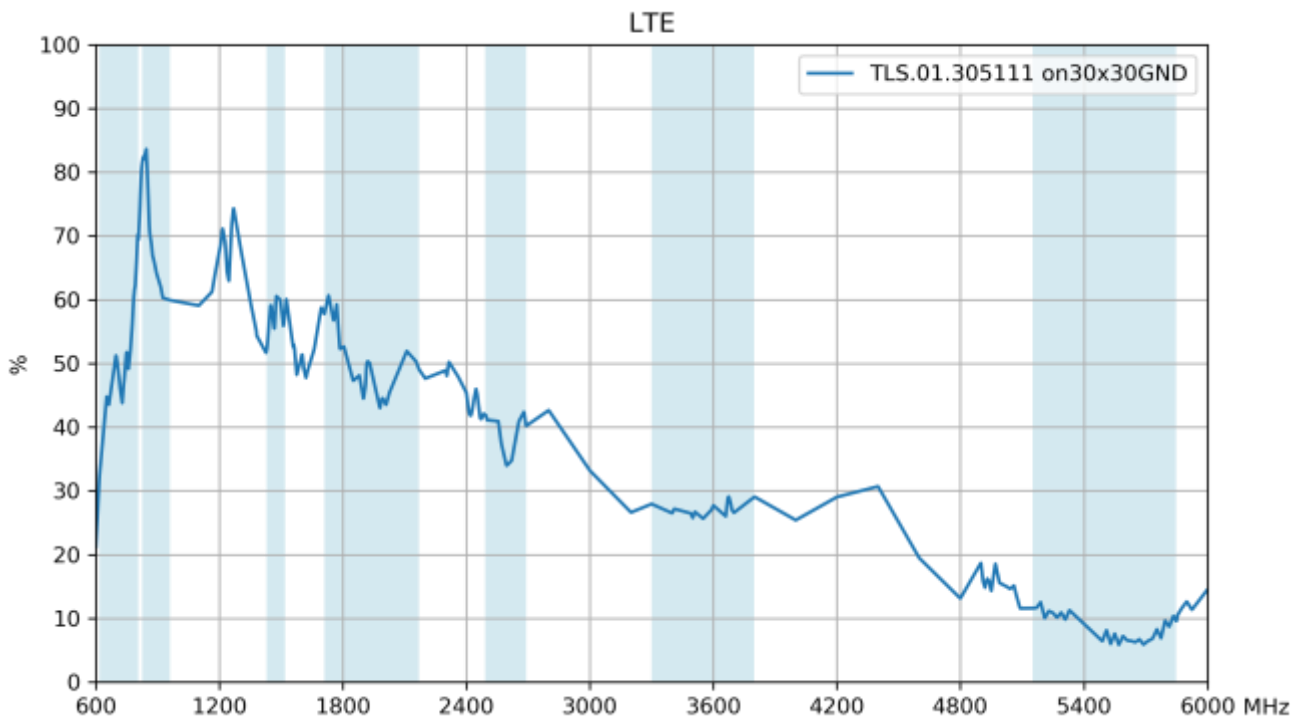

3.4 Average Gain

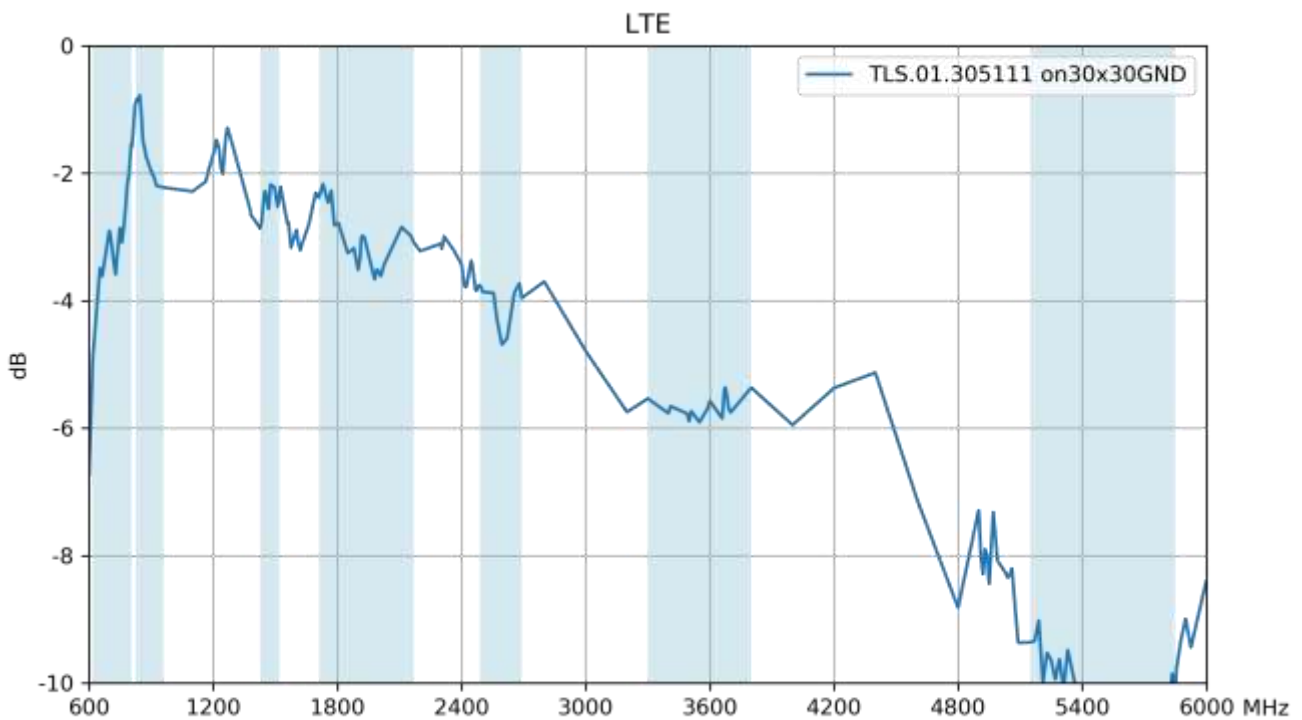

3.5 Peak Gain

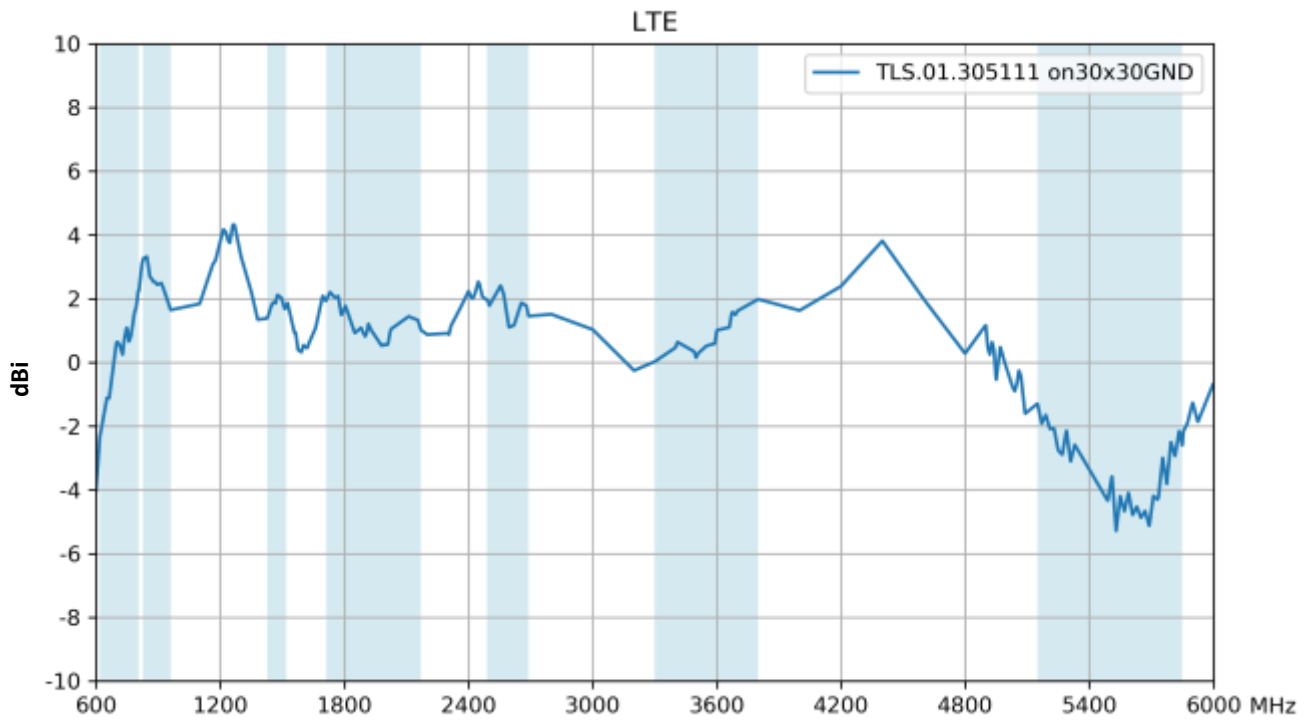

4. Radiation Patterns

4.1 Test Setup

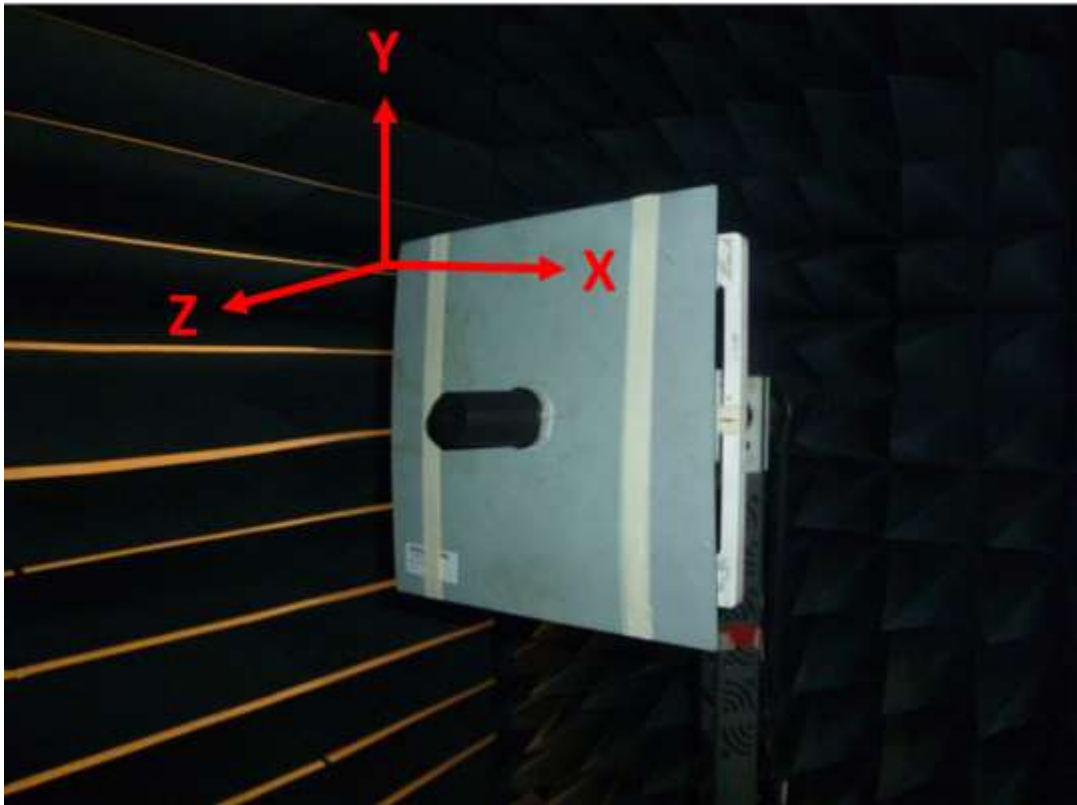

30*30cm Ground Plane

4.2 652MHz 3D and 2D Radiation Patterns

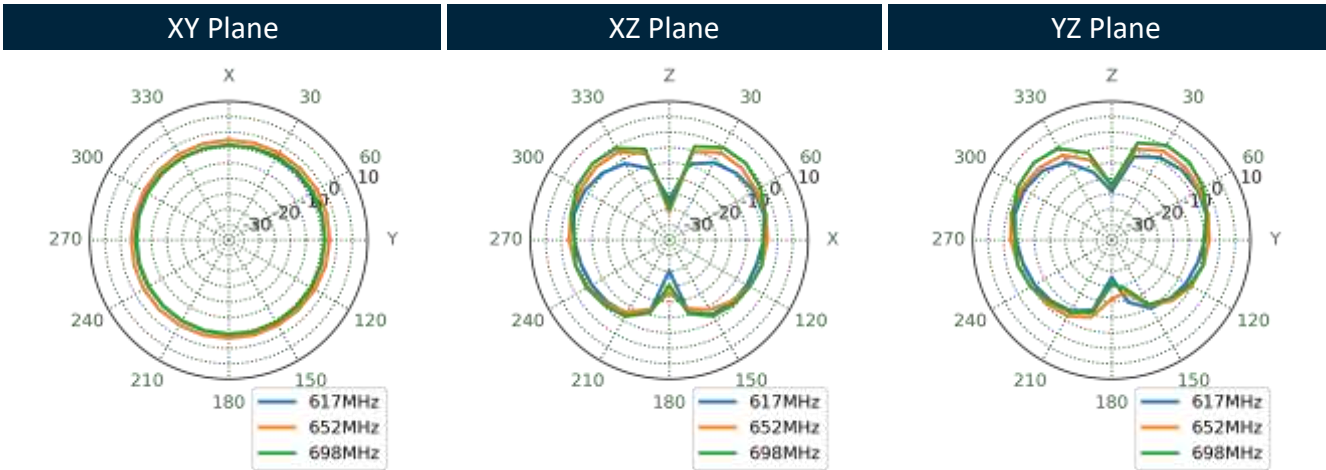
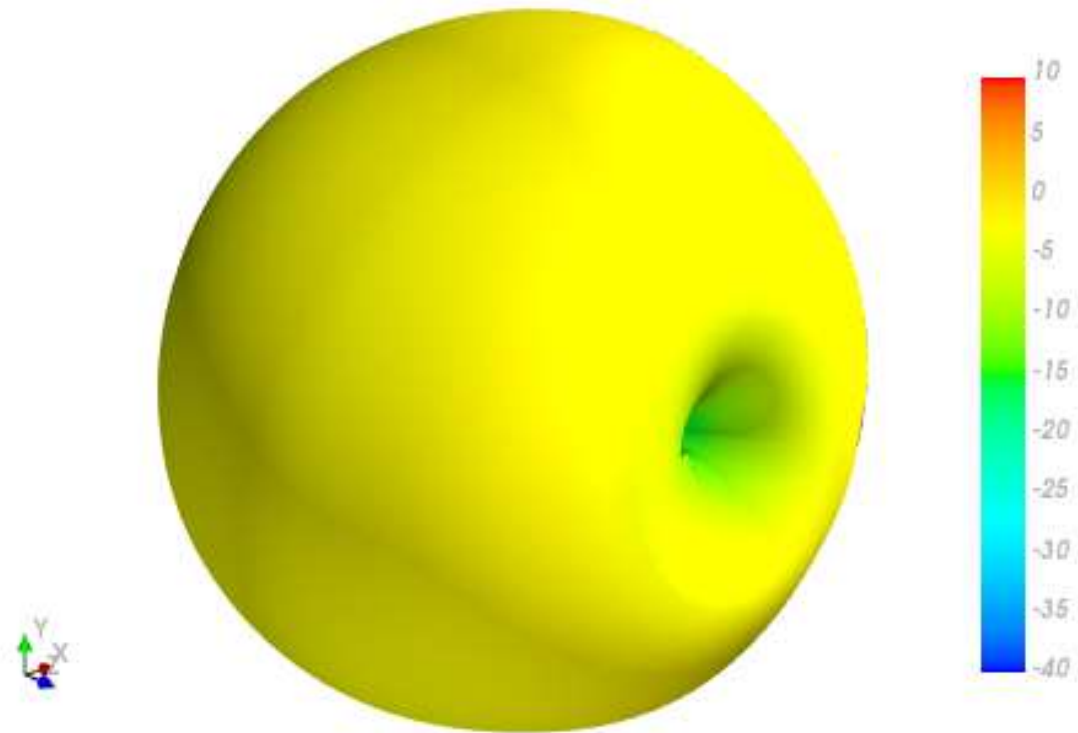

4.3 751MHz 3D and 2D Radiation Patterns

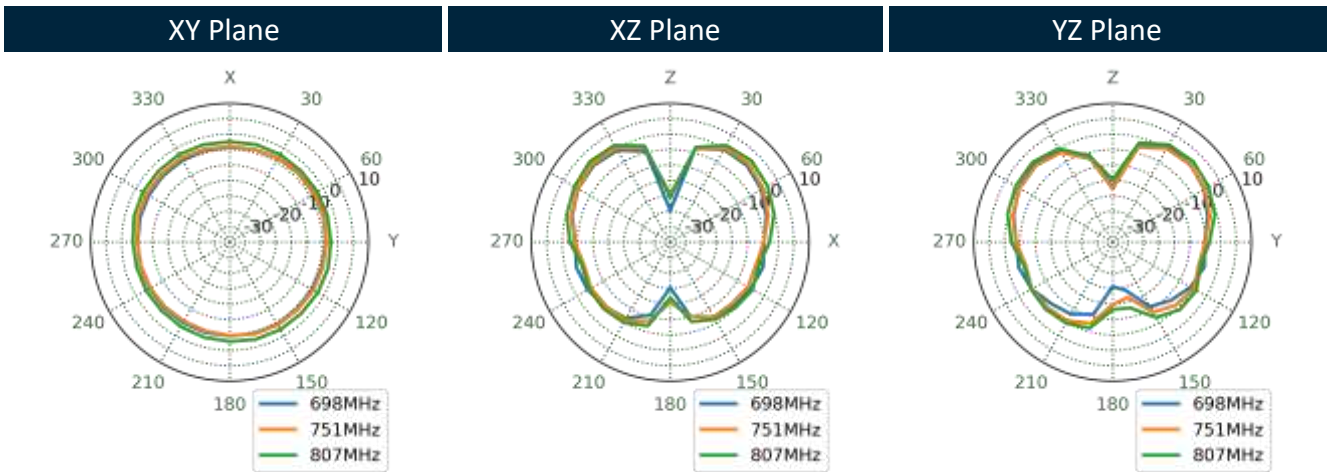
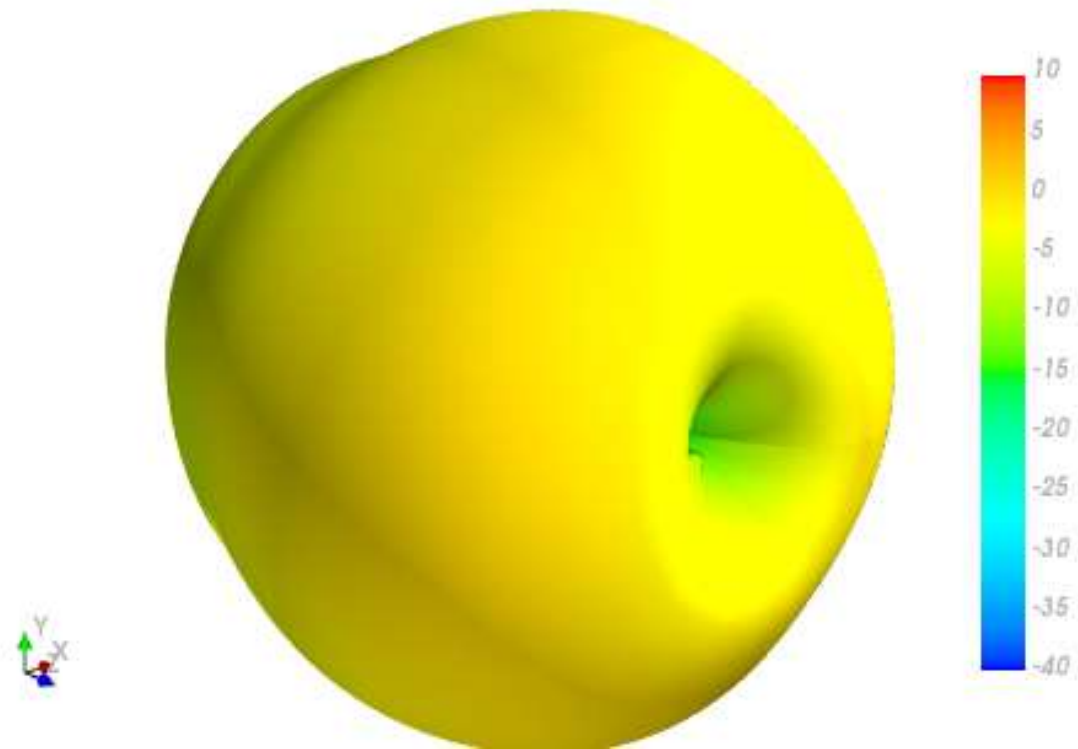

4.4 890MHz 3D and 2D Radiation Patterns

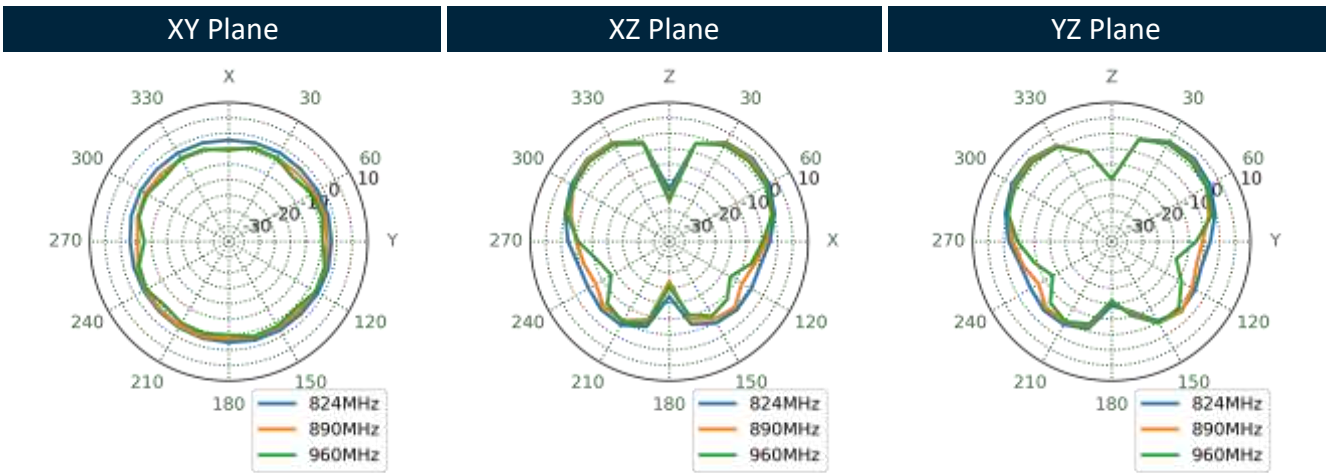
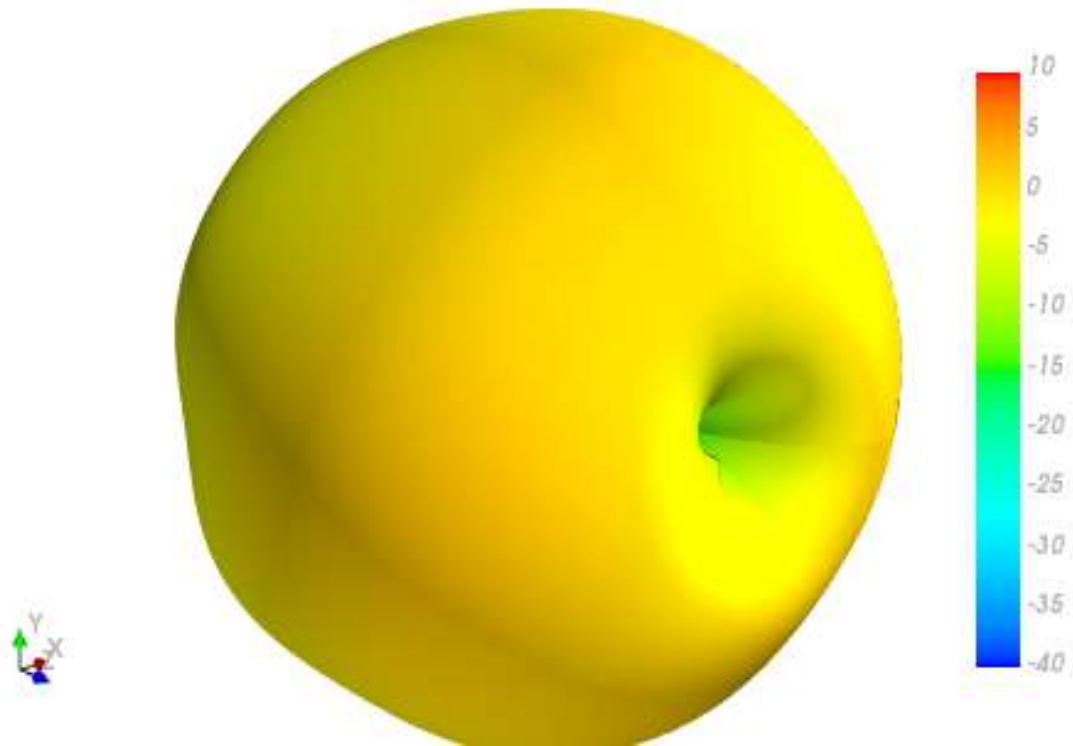

4.5 1470MHz 3D and 2D Radiation Patterns

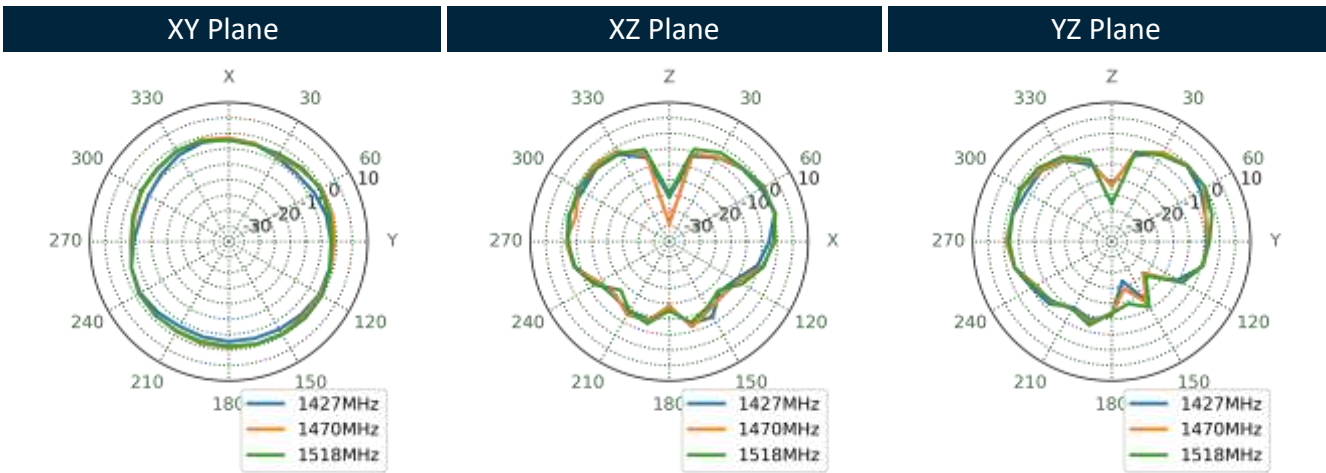
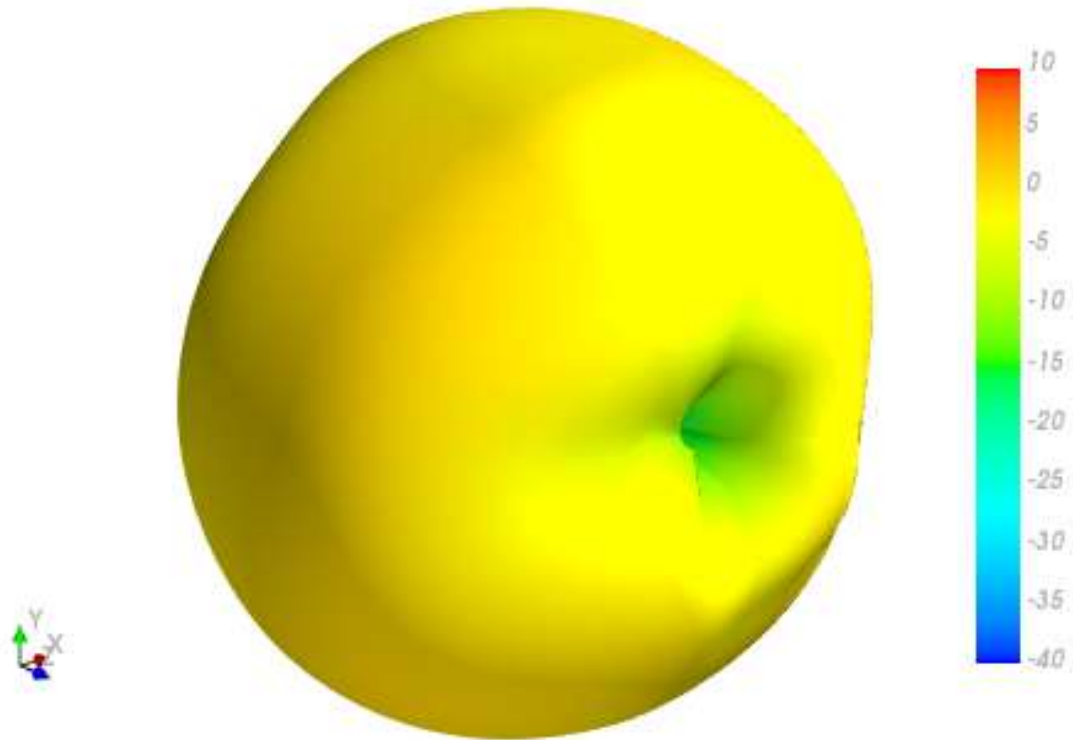

4.6 1805MHz 3D and 2D Radiation Patterns

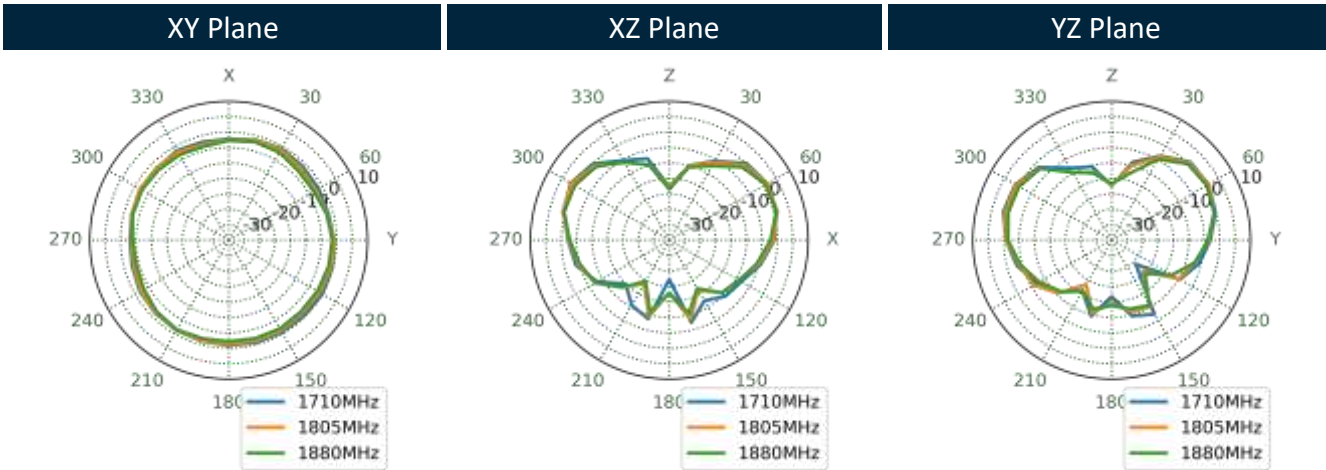
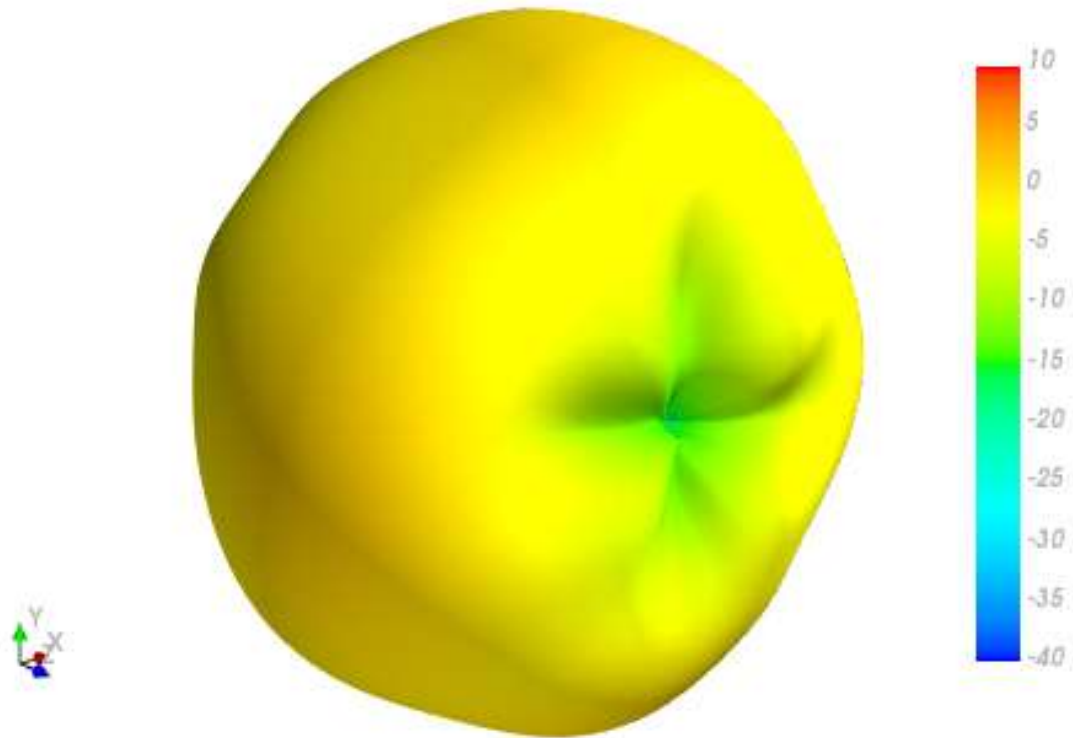

4.7 1920MHz 3D and 2D Radiation Patterns

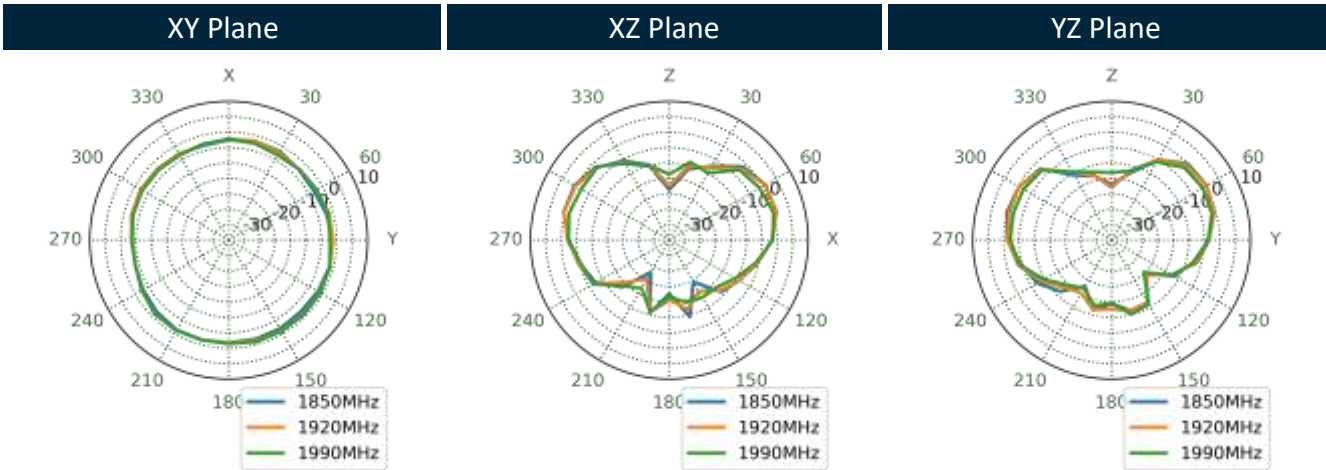
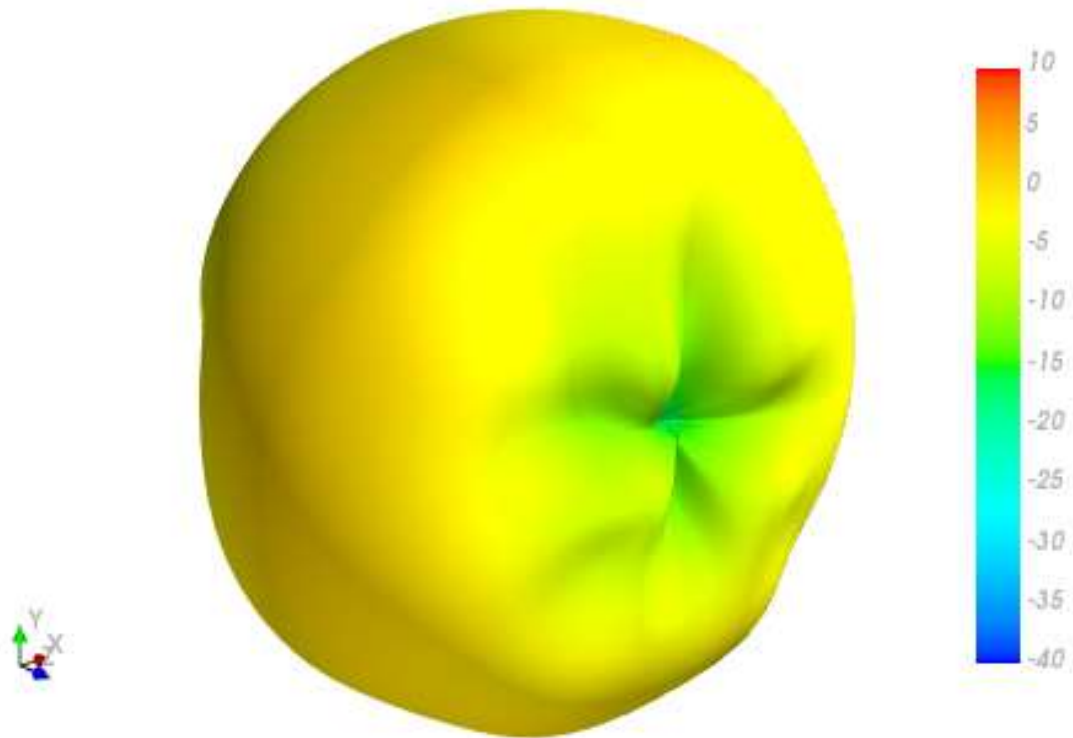

4.8 1990MHz 3D and 2D Radiation Patterns

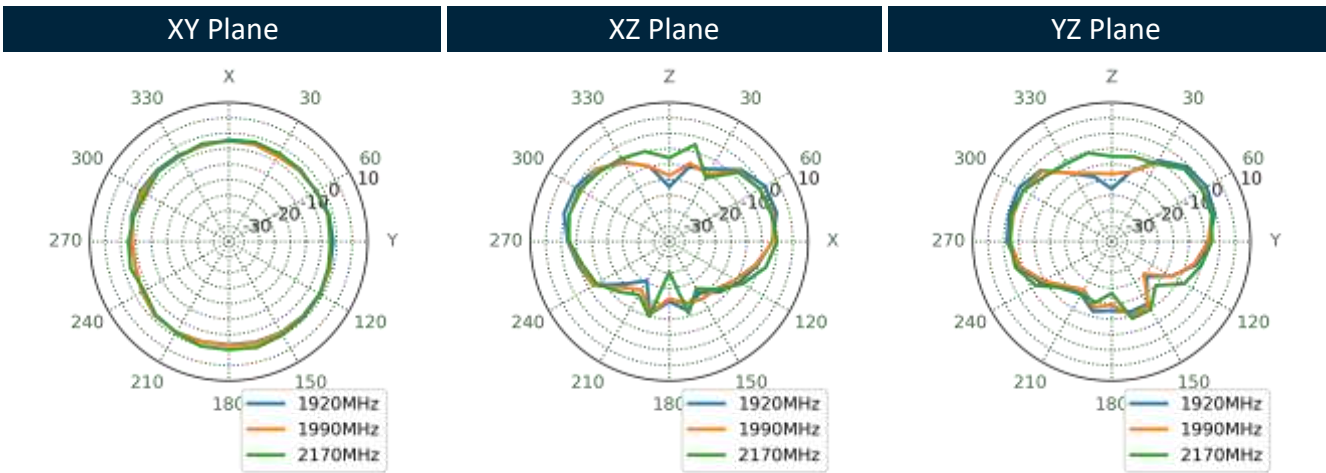
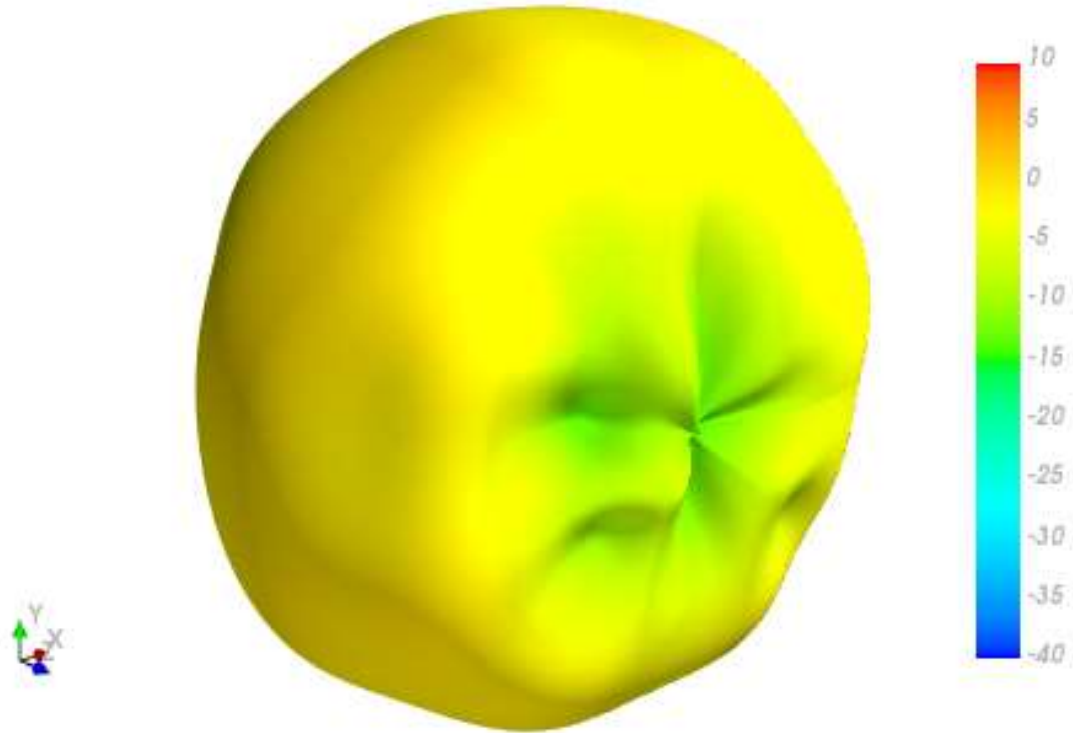

4.9 2595MHz 3D and 2D Radiation Patterns

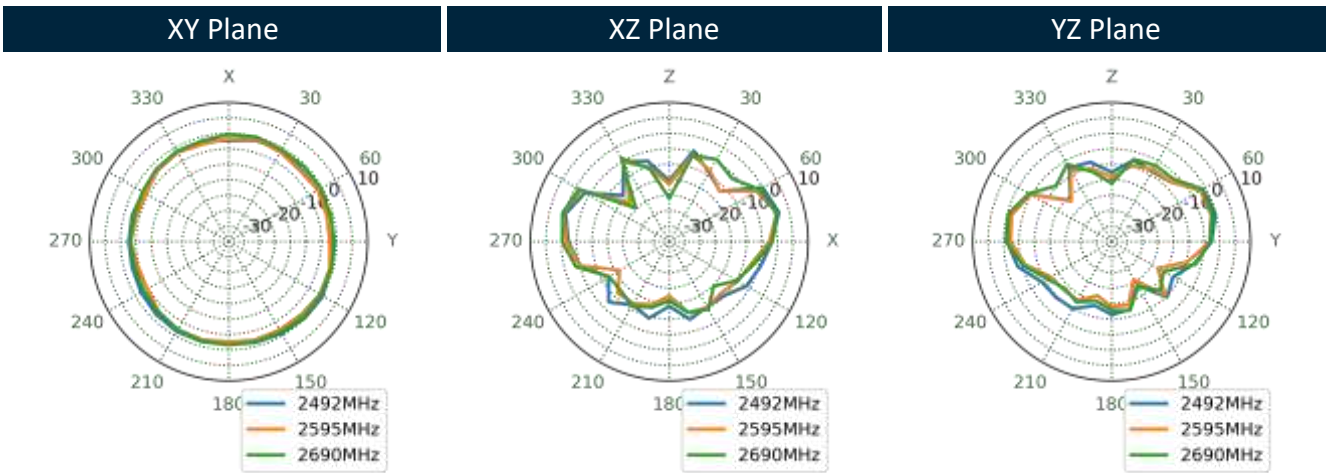
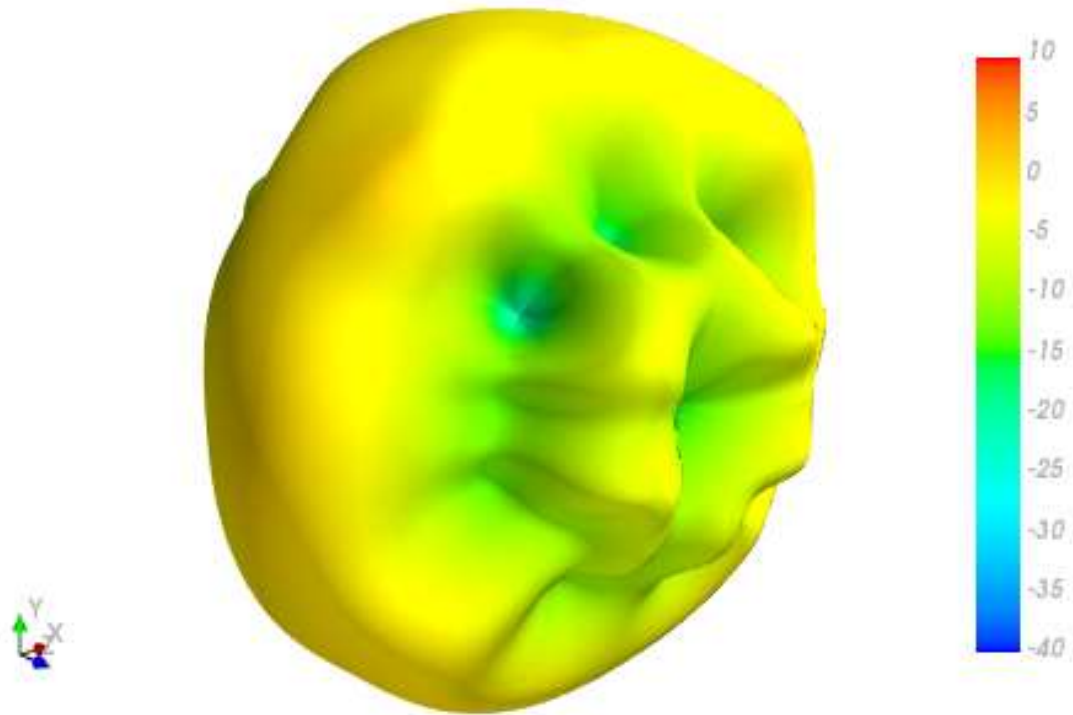

4.10 3550MHz 3D and 2D Radiation Patterns

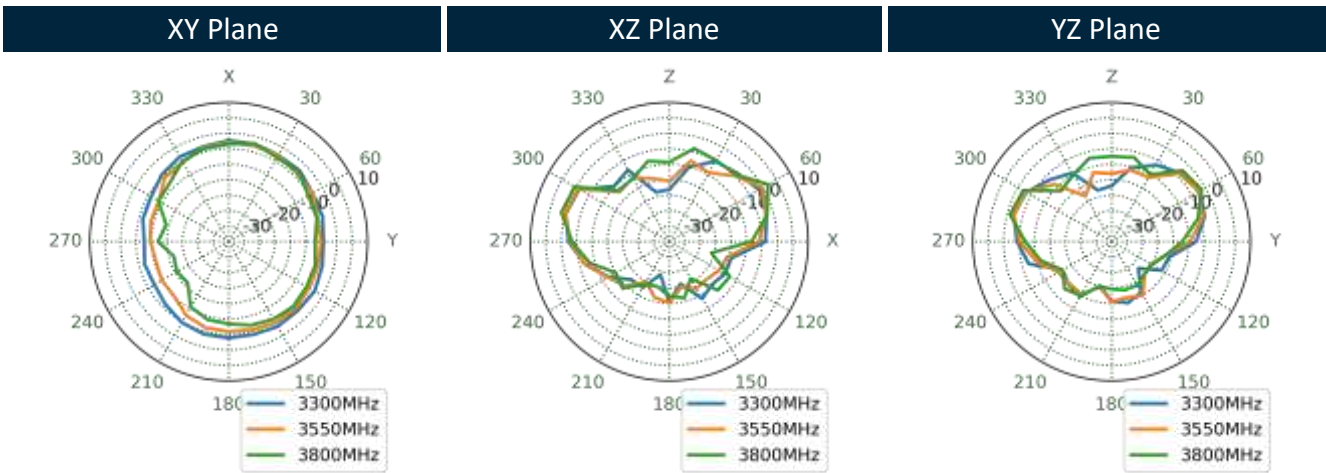
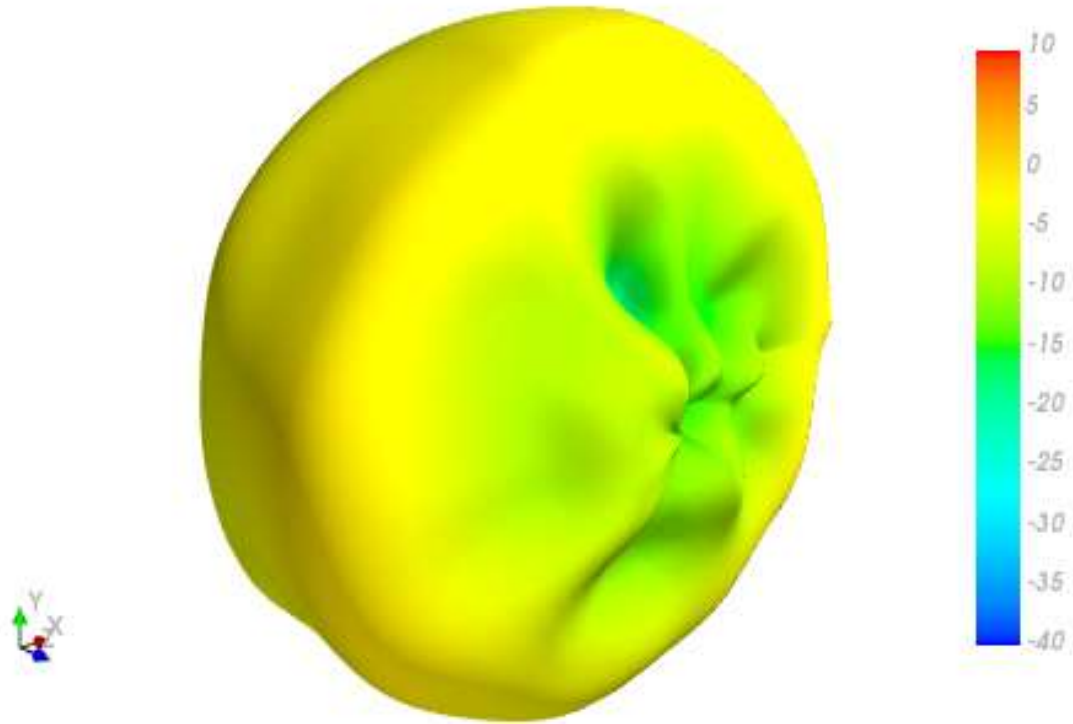

5. Mechanical Drawing (Units: mm)

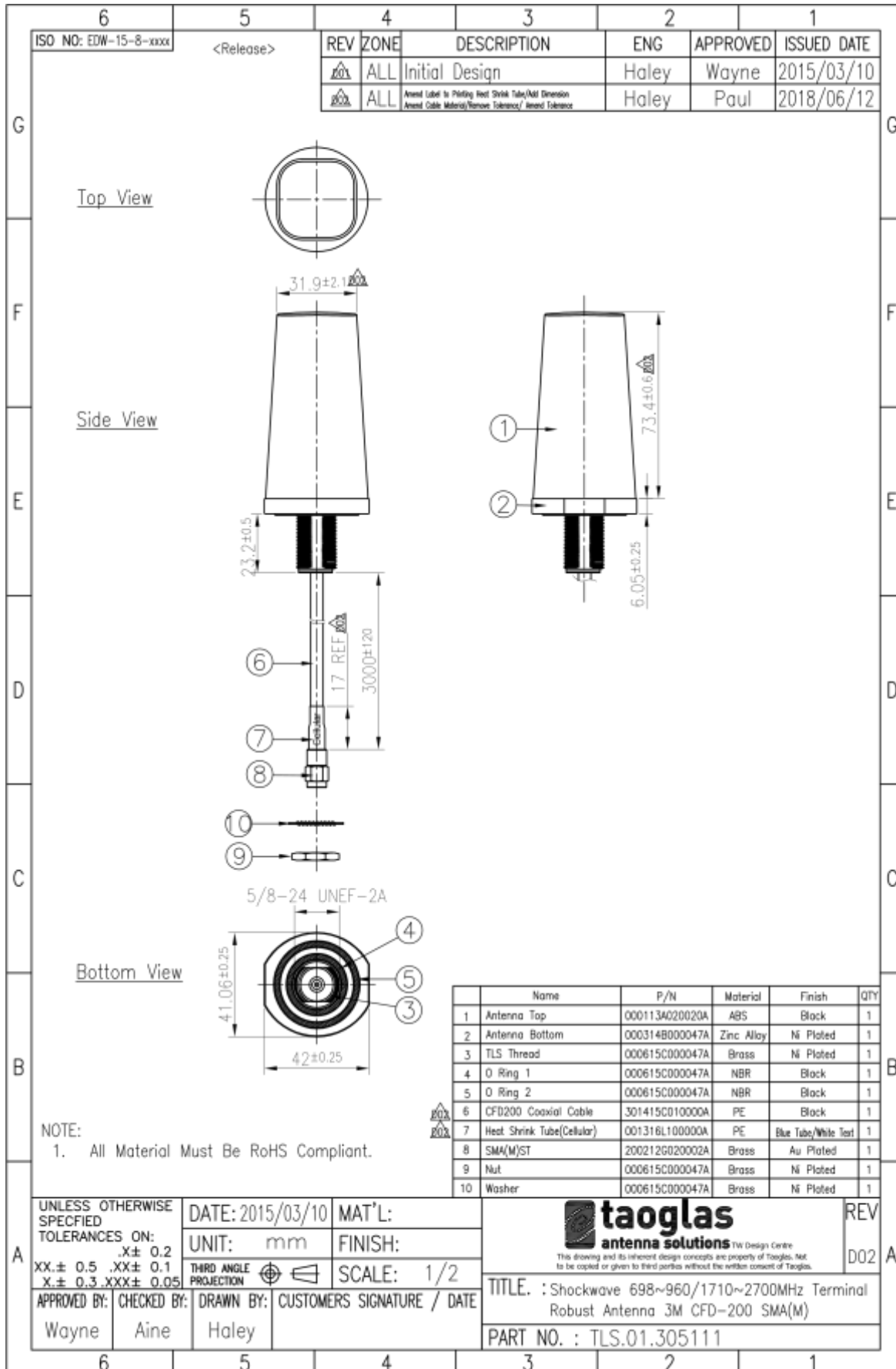

6. Installation Guidelines

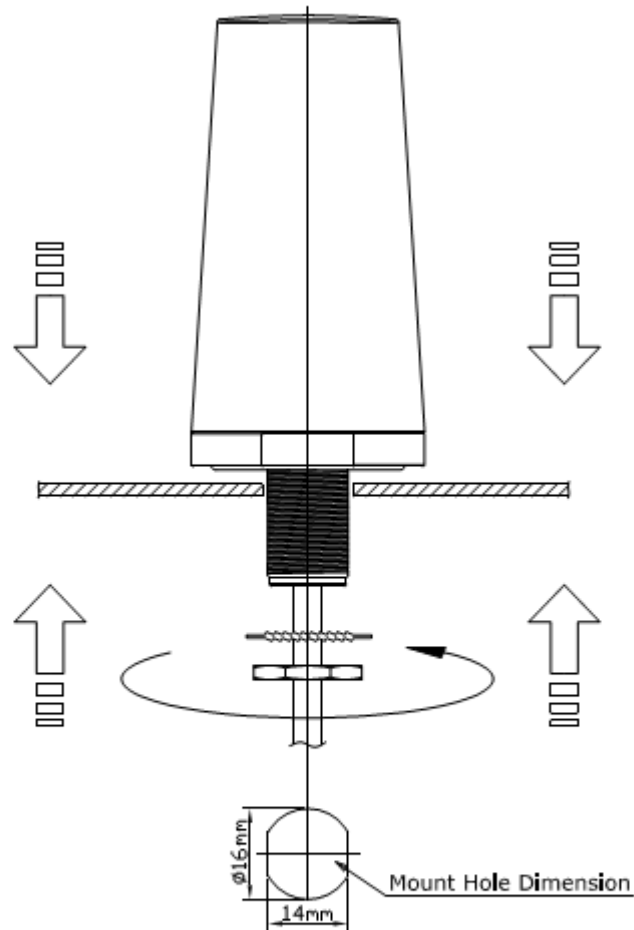

Recommended torque for mounting is 4.018 N.m or 41 kgf.cm

Maximum torque for mounting is 9.8 N.m or 100 kgf.cm

7. Packaging

TLS.01.305111

Packaging Specifications

1 No. TLS.01.305111 per small box
 Box Dimensions - 135 x 135 x 135mm
 Weight - 370g

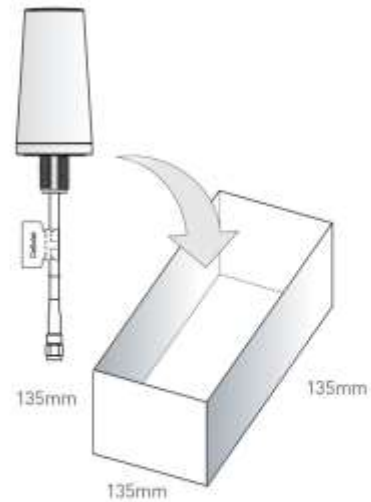

1 Outer Carton
 Carton Dimensions - 430 x 380 x 280mm
 24 pcs TLS.01.305111 per carton
 Weight - 10.2Kg

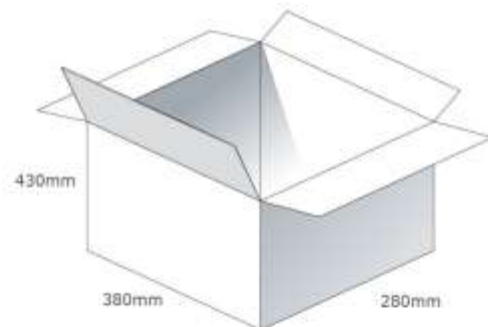

Pallet Dimensions 1100*1100*1510mm
 16 Cartons per Pallet
 4 Cartons per layer
 4 Layers

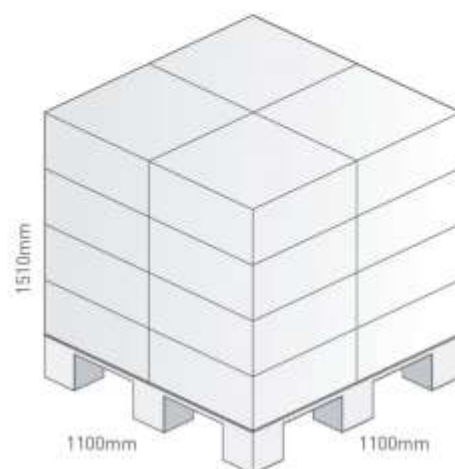

8. Application Note

8.1 Efficiency

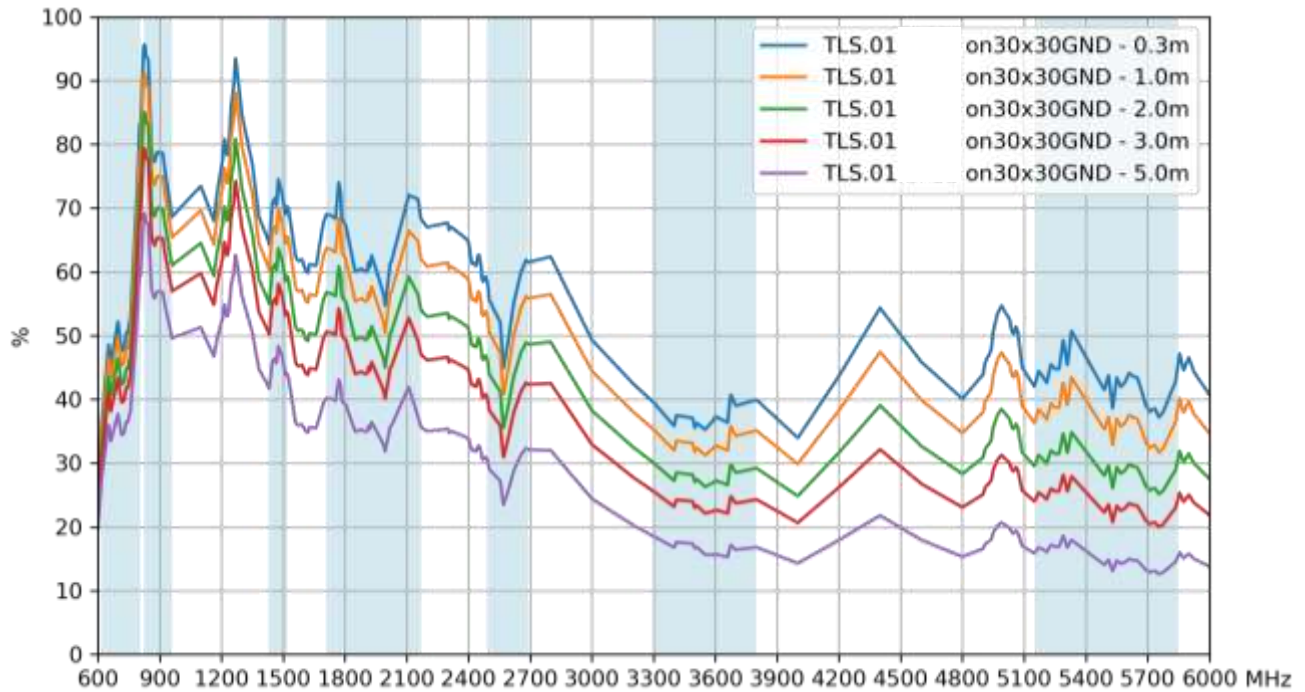

8.2 Peak Gain

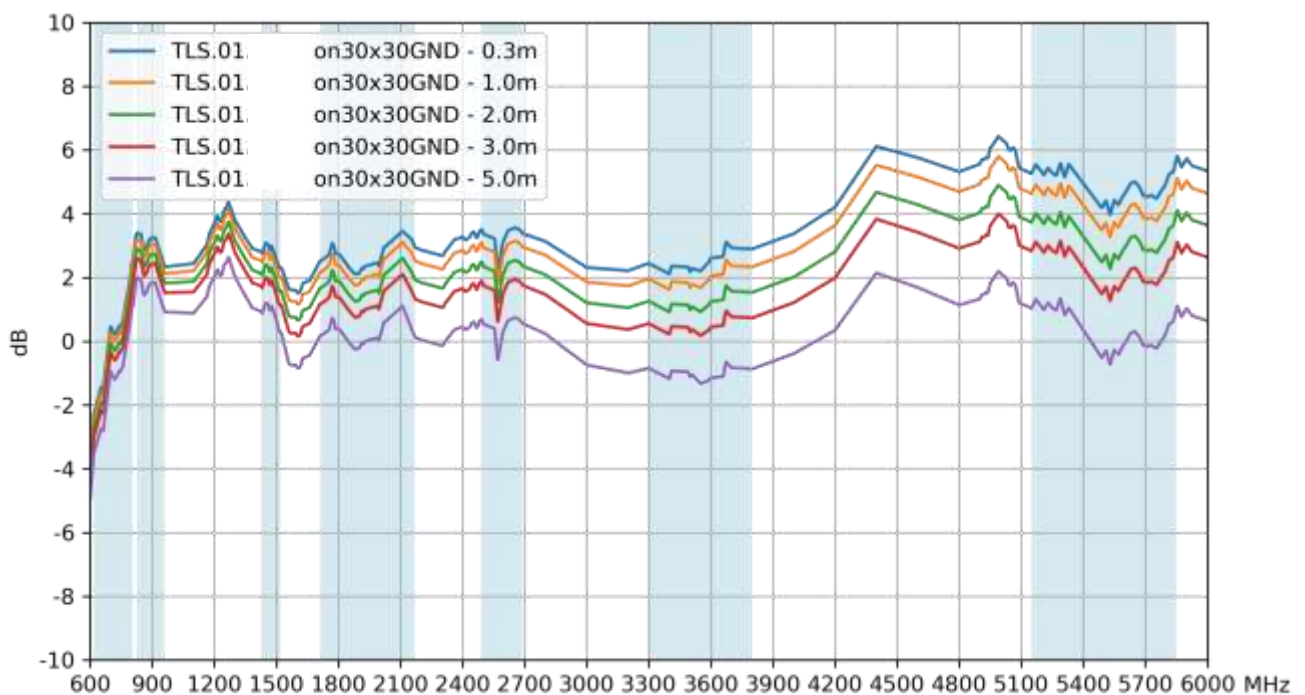

8.3 Average Gain

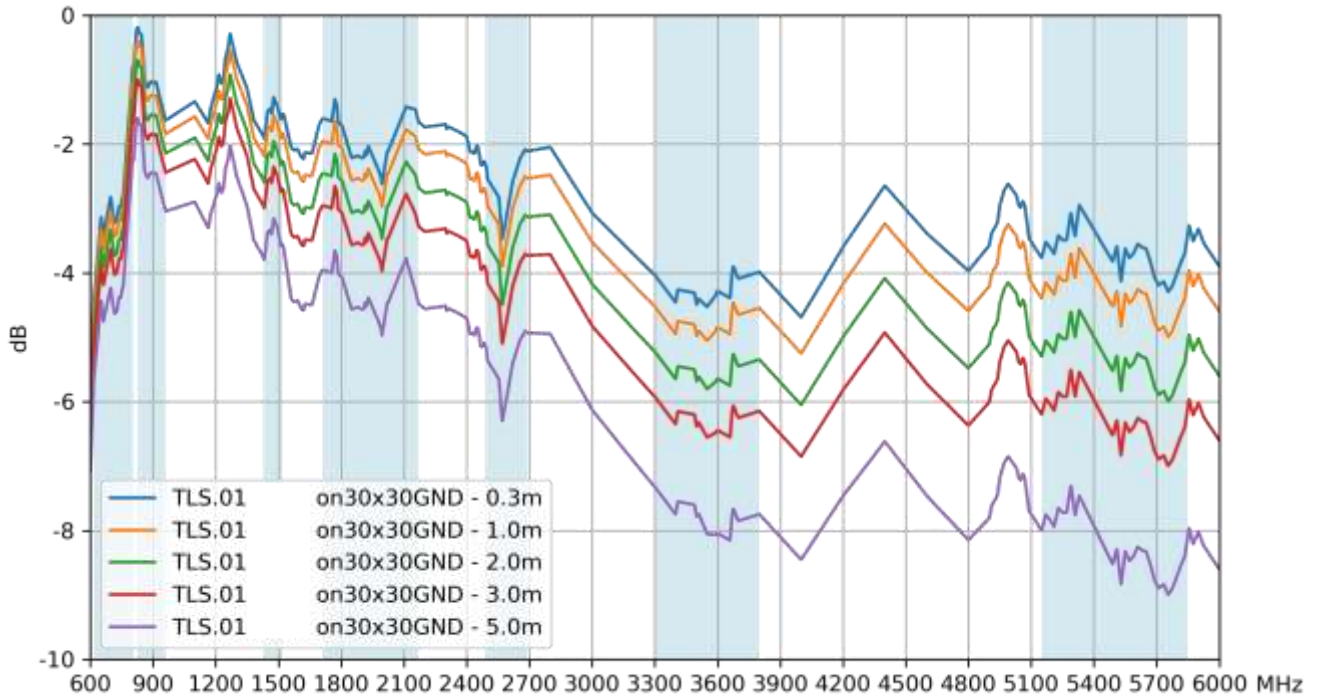

Changelog for the datasheet

SPE-15-8-063 – TLS.01.305111

Revision: H (Current Version)

Date:	2022-01-05
Changes:	Add VSWR plot
Changes Made by:	Ham Yang

Previous Revisions

Revision: G

Date:	Date:
Changes:	Changes:
Changes Made by:	Changes Made by:

Revision: B

Date:	2015-11-27
Changes:	
Changes Made by:	Jack Conroy

Revision: F

Date:	Date:
Changes:	Changes:
Changes Made by:	Changes Made by:

Revision: A (Original First Release)

Date:	2015-11-27
Notes:	
Author:	Jack Conroy

Revision: E

Date:	Date:
Changes:	Changes:
Changes Made by:	Changes Made by:

Revision: D

Date:	Date:
Changes:	Changes:
Changes Made by:	Changes Made by:

Revision: C

Date:	Date:
Changes:	Changes:
Changes Made by:	Changes Made by:



www.taoglas.com

