

**ebm-papst Mulfingen GmbH & Co. KG**

Bachmühle 2 · D-74673 Mulfingen

Phone +49 7938 81-0

Fax +49 7938 81-110

info1@de.ebmpapst.com

www.ebmpapst.com

Limited partnership · Headquarters Mulfingen

Amtsgericht (court of registration) Stuttgart · HRA 590344

General partner Elektrobau Mulfingen GmbH · Headquarters Mulfingen

Amtsgericht (court of registration) Stuttgart · HRB 590142

**Nominal data**

<b>Type</b>	<b>W1G250-HJ14-02</b>	
<b>Motor</b>	<b>M1G074-BF</b>	
Nominal voltage	VDC	24
Nominal voltage range	VDC	16 .. 28
Method of obtaining data		fa
Speed (rpm)	min <sup>-1</sup>	3000
Power consumption	W	120
Current draw	A	5.0
Max. back pressure	Pa	140
Max. back pressure	in. wg	0.56
Min. ambient temperature	°C	-25
Max. ambient temperature	°C	60

ml = Max. load · me = Max. efficiency · fa = Free air · cs = Customer specification · ce = Customer equipment  
Subject to change

**Data according to Commission Regulation (EU) 327/2011**

		Actual	Req. 2015
01 Overall efficiency $\eta_{es}$	%	41.8	28.1
02 Measurement category		A	
03 Efficiency category		Static	
04 Efficiency grade N		53.7	40
05 Variable speed drive		Yes	

Data obtained at optimum efficiency level.

The ErP data is determined using a motor-impeller combination in a standardized measurement setup.

09 Power consumption $P_e$	kW	0.13
09 Air flow $q_v$	m <sup>3</sup> /h	1405
09 Pressure increase $p_{fs}$	Pa	122
10 Speed (rpm) $n$	min <sup>-1</sup>	2685
11 Specific ratio <sup>*</sup>		1.00

<sup>\*</sup> Specific ratio =  $1 + p_{fs} / 100\,000\text{ Pa}$ 

LU-191336



## Technical description

<b>Weight</b>	2.35 kg
<b>Size</b>	250 mm
<b>Motor size</b>	74
<b>Rotor surface</b>	Galvanized
<b>Electronics housing material</b>	Die-cast aluminum, painted black
<b>Impeller material</b>	PP plastic
<b>Fan housing material</b>	Die-cast aluminum
<b>Number of blades</b>	7
<b>Airflow direction</b>	V
<b>Direction of rotation</b>	Counterclockwise, viewed toward rotor
<b>Degree of protection</b>	Motor IP24, electronics IP69
<b>Insulation class</b>	"B"
<b>Moisture (F) / Environmental (H) protection class</b>	H2+
<b>Ambient temperature note</b>	Occasional start-up between -40°C and -25°C is permissible. For continuous operation at temperatures below -25°C (e.g. refrigeration applications) we recommend our fan design with special low-temperature bearings.
<b>Max. permitted ambient temp. for motor (transport/storage)</b>	+80 °C
<b>Min. permitted ambient temp. for motor (transport/storage)</b>	-40 °C
<b>Installation position</b>	Shaft horizontal or rotor on bottom; rotor on top on request
<b>Condensation drainage holes</b>	On rotor side
<b>Mode</b>	S1
<b>Motor bearing</b>	Ball bearing; (sealed)
<b>Technical features</b>	<ul style="list-style-type: none"> <li>- Tach output</li> <li>- Motor current limitation</li> <li>- Soft start</li> <li>- Control input 0-10 VDC / PWM</li> <li>- Overvoltage detection</li> <li>- Thermal overload protection for electronics</li> <li>- Reverse polarity protection</li> </ul>
<b>Electrical hookup</b>	Via terminal strip
<b>Approval</b>	EAC

Product drawing

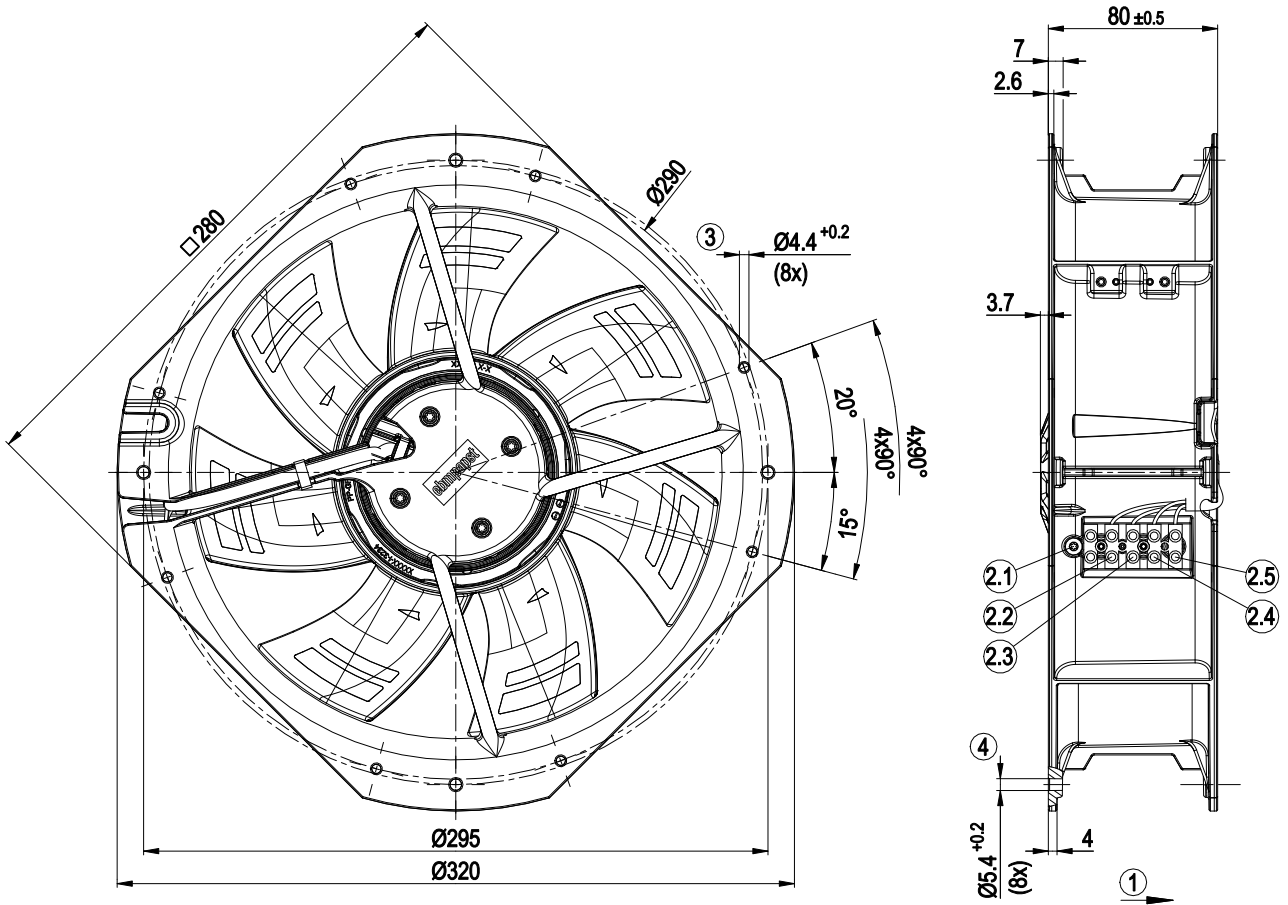

1	Airflow direction "V"
2.1	Ground connection point
2.2	Control input
2.3	Speed monitoring
2.4	-
2.5	+
3	For self-tapping M5 screws
4	For self-tapping M6 screws

## Connection diagram

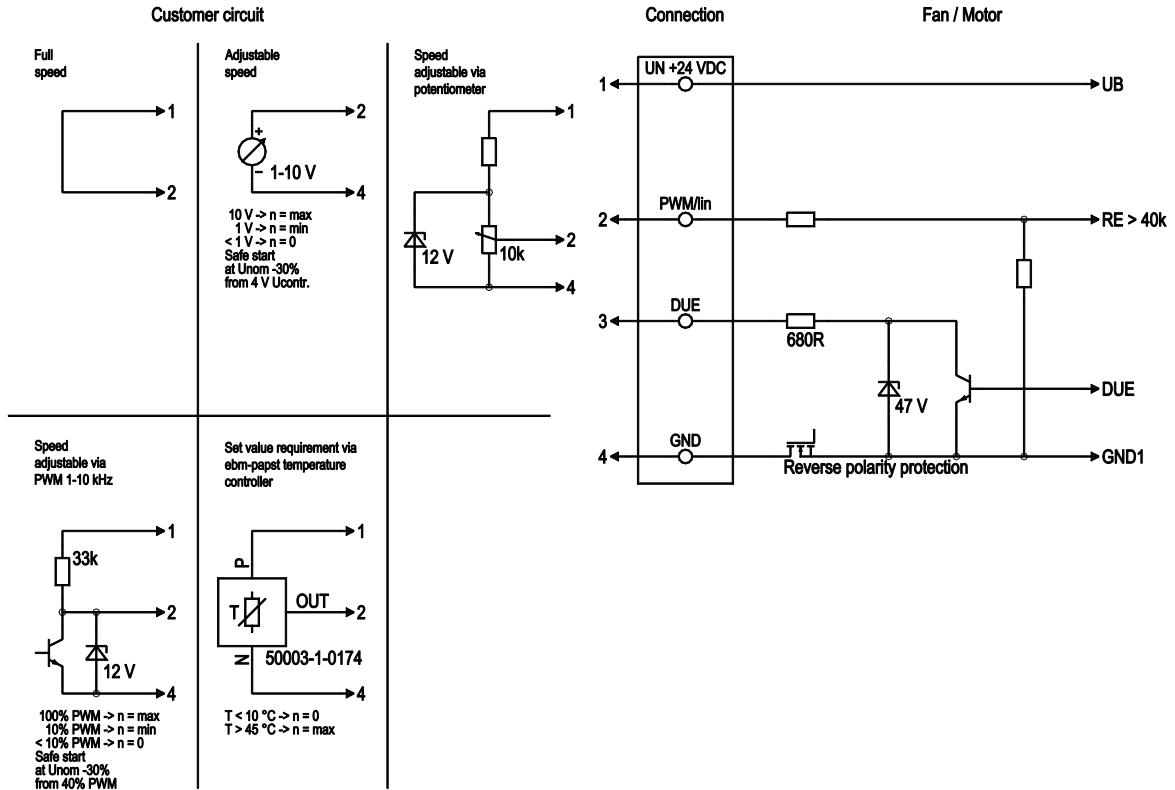

No.	Conn.	Designation	Color	Function/assignment
	1	UN +24 VDC	red	Power supply 24 VDC, maximum ripple 3.5%
	2	PWM/LIN	yellow	Control input Re > 40k
	3	DUE	white	Tach output, 3 pulses per revolution, Isink max = 10 mA
	4	GND	blue	Reference ground

## Curves: Air performance

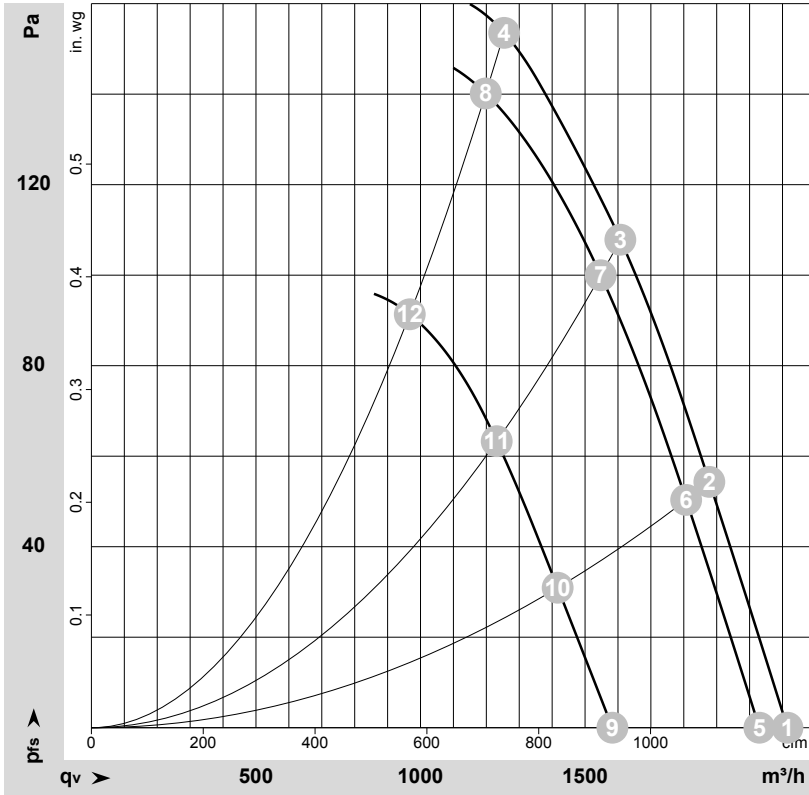

$\rho = 1.15 \text{ kg/m}^3 \pm 2 \%$

Measurement: LU-191421-1  
 Measurement: LU-191336-1  
 Measurement: LU-191420-1

Air performance measured according to ISO 5801 installation category A. For detailed information on the measurement setup, contact ebm-papst. Intake sound level: Sound power level according to ISO 13347 / sound pressure level measured at 1 m distance from fan axis. The values given are valid under the specified measuring conditions and may vary due to conditions of installation. For deviations from the standard configuration, the parameters have to be checked on the installed unit.

## Measured values

	U	n	P <sub>ed</sub>	I	q <sub>v</sub>	p <sub>fs</sub>	q <sub>v</sub>	p <sub>fs</sub>
	V	min <sup>-1</sup>	W	A	m <sup>3</sup> /h	Pa	cfm	in. wg
1	28	3135	135	5.93	2115	0	1245	0.00
2	28	2975	139	6.21	1880	55	1105	0.22
3	28	2840	143	6.50	1605	108	945	0.43
4	28	2760	148	6.77	1255	156	740	0.63
5	24	3000	120	6.00	2030	0	1195	0.00
6	24	2880	127	6.30	1805	50	1065	0.20
7	24	2745	130	6.50	1550	100	910	0.40
8	24	2645	131	6.65	1200	140	705	0.56
9	16	2360	60	4.38	1585	0	930	0.00
10	16	2275	63	4.66	1415	31	835	0.12
11	16	2205	67	4.92	1230	63	725	0.25
12	16	2145	70	5.16	965	92	570	0.37

U = Voltage · n = Speed (rpm) · P<sub>ed</sub> = Power consumption · I = Current draw · q<sub>v</sub> = Air flow · p<sub>fs</sub> = Pressure increase

