



XC303 modular PLC, small PLC, programmable CODESYS 3, SD Slot, USB, 2x Ethernet, CAN, RS485

Part no. XC-303-C21-001
Catalog No. 191081
Alternate Catalog No. XC-303-C21-001

Similar to illustration

Delivery program

Approvals			CE, cULus EAC
certificate			CE
Connection design in TOP direction			Push-in spring-cage terminal

Technical data

General

Standards			EN 61131
Approvals			
Approvals			CE, cULus EAC
certificate			CE
Electromagnetic compatibility (EMC)			
ESD	Air/contact discharge	kV	8 / 4
Electromagnetic fields	(0.08...1) / (1,4...2) / (2...2,7) GHz	V/m	10 / 3 / 1
Burst			
Supply cable		kV	2
Signal cable		kV	1
Surge			
Supply cable (balanced / unbalanced)		kV	0,5 / 0,5
Signal cable (unbalanced)		kV	1
Radiated RFI		V	10
Emitted interference (radiated, high frequency)	(30...230 MHz) / (230...1000 MHz)	dB	40 / 47 class A
Voltage fluctuations/voltage dips			Yes / 20 ms
Ambient conditions			
Climatic conditions			
Climatic proofing			Dry heat to IEC 60068-2-2 Damp heat as per EN 60068-2-3
Air pressure (operation)		hPa	795 - 1080
Relative humidity			< 95%, non-condensing
Condensation			prevent with suitable measures
Temperature			
Operation		°C	-25 - +55
Storage, transport	θ	°C	-25 - +80
Degree of Protection			IP20
Mounting position			Vertical (on horizontal top-hat rail)
Free fall, packaged (IEC/EN 60068-2-32)		m	1
Vibrations	3,5 mm / 1 g	Hz	5 - 8.4 / 8.4 -150
Mechanical shock resistance	Semisinusoida Impacts		9 15 g/11 ms

Terminations

Rated operational data			
------------------------	--	--	--

Insulating material group			I
Overtoltage category / pollution degree			II / 2
Rated operating voltage		V	160
Maximum load current/cross-sectional area		A / mm ²	6/1.5
Connection design in TOP direction			Push-in spring-cage terminal
Stripping length		mm	10
Gauge pin IEC/EN 60947-1			A1
Connection specifications			
"e" solid H07V-U		mm ²	0.2 - 1.5
"f" flexible H 07V-K		mm ²	0.2 - 1.5
"f" with ferrules without plastic collar according to DIN 46228-1 (ferrules crimped gas-tight)		mm ²	0.25-1.5
"f" with ferrules with plastic collar according to DIN 46228-1 (ferrules crimped gas-tight)		mm ²	0.25-1.5
Cable size		AWG	24 - 16

Supply

Power supply - Input			
Power supply			
Rated operating voltage	U _e	V	24
Rated operational current	I _e	A	2.8
Potential isolation	PE (polyethylene)		No
Heat dissipation			
Max. heat dissipation		W	8
Notes on heat dissipation			The max. heat dissipation is specified as the maximum power produced inside the device's housing.

Digital inputs

Channels		Number	4 (interruptfähig)
Input voltage			
Nominal input voltage	U _e	V DC	24
Low level	U _{eL}	V	0 < U _{eL} < +5
High level	U _{eH}	V	+15 < U _{eH} < +30
Input current			
Input current, nominal value	I _e	mA	2
Low level/active level	I _{eL}	mA	≤1.1
High level/active level	I _{eH}	mA	≥2.3
Input delay			
t _{Rising edge}		μs	< 300
t _{Falling edge}		μs	< 300
Potential isolation		Input to input	No
Heat dissipation (per active channel)		W	0.05 inputs as per EN61131-2 Type 1; inputs can also be operated as outputs

Digital outputs

Channels		Quantity	4
Output current		A	
Output current, nominal value	I _{aL}	A	0.5
Short-circuit rating			Yes
Potential isolation		Output against output	No
Heat dissipation (internal, per active channel)		W	0.1
Utilization factor	%	g	100% (# I _{Amax} = 2A)
Delay on signal change and resistive load			
from Low to High level		μs	200
From High to Low signal		μs	200
Notes on digital outputs			Protective devices must be installed directly at the inductive load in order to prevent interference.

Design verification as per IEC/EN 61439

Technical data for design verification			
Static heat dissipation, non-current-dependent	P _{vs}	W	8
Operating ambient temperature min.		°C	-25
Operating ambient temperature max.		°C	55
Degree of Protection			IP20
IEC/EN 61439 design verification			
10.2 Strength of materials and parts			
10.2.2 Corrosion resistance			
			Meets the product standard's requirements.
10.2.3.1 Verification of thermal stability of enclosures			
			Meets the product standard's requirements.
10.2.3.2 Verification of resistance of insulating materials to normal heat			
			Meets the product standard's requirements.
10.2.3.3 Verification of resistance of insulating materials to abnormal heat and fire due to internal electric effects			
			Meets the product standard's requirements.
10.2.4 Resistance to ultra-violet (UV) radiation			
			Meets the product standard's requirements.
10.2.5 Lifting			
			Does not apply, since the entire switchgear needs to be evaluated.
10.2.6 Mechanical impact			
			Does not apply, since the entire switchgear needs to be evaluated.
10.2.7 Inscriptions			
			Meets the product standard's requirements.
10.3 Degree of protection of ASSEMBLIES			
			Meets the product standard's requirements.
10.4 Clearances and creepage distances			
			Meets the product standard's requirements.
10.5 Protection against electric shock			
			Does not apply, since the entire switchgear needs to be evaluated.
10.6 Incorporation of switching devices and components			
			Does not apply, since the entire switchgear needs to be evaluated.
10.7 Internal electrical circuits and connections			
			Is the panel builder's responsibility.
10.8 Connections for external conductors			
			Is the panel builder's responsibility.
10.9 Insulation properties			
10.9.2 Power-frequency electric strength			
			Is the panel builder's responsibility.
10.9.3 Impulse withstand voltage			
			Is the panel builder's responsibility.
10.9.4 Testing of enclosures made of insulating material			
			Is the panel builder's responsibility.
10.10 Temperature rise			
			The panel builder is responsible for the temperature rise calculation. Eaton will provide heat dissipation data for the devices.
10.11 Short-circuit rating			
			Is the panel builder's responsibility.
10.12 Electromagnetic compatibility			
			Is the panel builder's responsibility.
10.13 Mechanical function			
			The device meets the requirements, provided the information in the instruction leaflet (IL) is observed.

Technical data ETIM 7.0

PLC's (EG000024) / PLC CPU-module (EC000236)			
Electric engineering, automation, process control engineering / Control / Programmable logic control (SPS) / SPS - basic device (ecl@ss10.0.1-27-24-22-07 [AKE530014])			
Supply voltage AC 50 Hz		V	0 - 0
Supply voltage AC 60 Hz		V	0 - 0
Supply voltage DC		V	18 - 30
Voltage type of supply voltage			DC
Number of relay outputs			0
Max. number of time switches			1000
Model			Modular
Processing time (1K, binary operation)		ms	0.0011
Number of HW-interfaces industrial Ethernet			2
Number of interfaces PROFINET			0
Number of HW-interfaces RS-232			0
Number of HW-interfaces RS-422			0
Number of HW-interfaces RS-485			1
Number of HW-interfaces USB			1
Number of HW-interfaces parallel			0
Number of HW-interfaces Wireless			0
Number of HW-interfaces other			1
Number of analogue outputs			0
Number of analogue inputs			0

Number of digital inputs		0
Number of digital outputs		0
With optical interface		No
Supporting protocol for TCP/IP		Yes
Supporting protocol for PROFIBUS		No
Supporting protocol for CAN		Yes
Supporting protocol for INTERBUS		No
Supporting protocol for ASI		No
Supporting protocol for KNX		No
Supporting protocol for MODBUS		Yes
Supporting protocol for Data-Highway		No
Supporting protocol for DeviceNet		No
Supporting protocol for SUCONET		No
Supporting protocol for LON		No
Supporting protocol for PROFINET IO		No
Supporting protocol for PROFINET CBA		No
Supporting protocol for SERCOS		No
Supporting protocol for Foundation Fieldbus		No
Supporting protocol for EtherNet/IP		Yes
Supporting protocol for AS-Interface Safety at Work		No
Supporting protocol for DeviceNet Safety		No
Supporting protocol for INTERBUS-Safety		No
Supporting protocol for PROFIsafe		No
Supporting protocol for SafetyBUS p		No
Supporting protocol for other bus systems		Yes
Radio standard Bluetooth		No
Radio standard WLAN 802.11		No
Radio standard GPRS		No
Radio standard GSM		No
Radio standard UMTS		No
IO link master		No
System accessory		Yes
Redundancy		Yes
With display		No
Type of memory		RAM
Memory size	kByte	512000
Additional program memory possible		Yes
Rail mounting possible		Yes
Wall mounting/direct mounting		No
Front build in possible		No
Rack-assembly possible		No
Suitable for safety functions		No
Category according to EN 954-1		
SIL according to IEC 61508		None
Performance level acc. EN ISO 13849-1		None
Appendant operation agent (Ex ia)		No
Appendant operation agent (Ex ib)		No
Explosion safety category for gas		None
Explosion safety category for dust		None
Width	mm	51
Height	mm	110
Depth	mm	81

Approvals

Product Standards		CE, cULus
-------------------	--	-----------

UL File No.	E205091
North America Certification	UL listed, certified by UL for use in Canada
Specially designed for North America	No
Current Limiting Circuit-Breaker	No

Dimensions

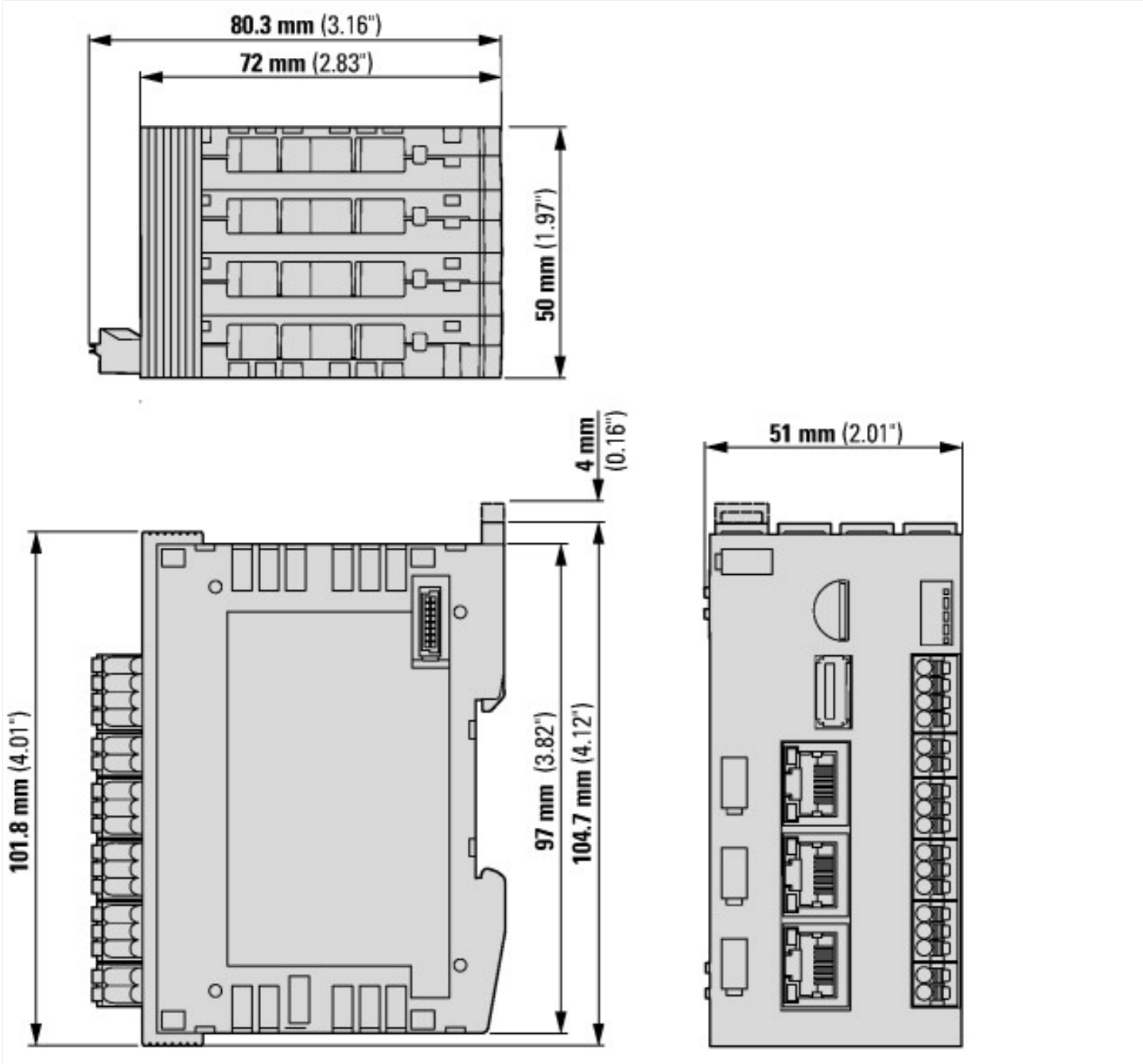

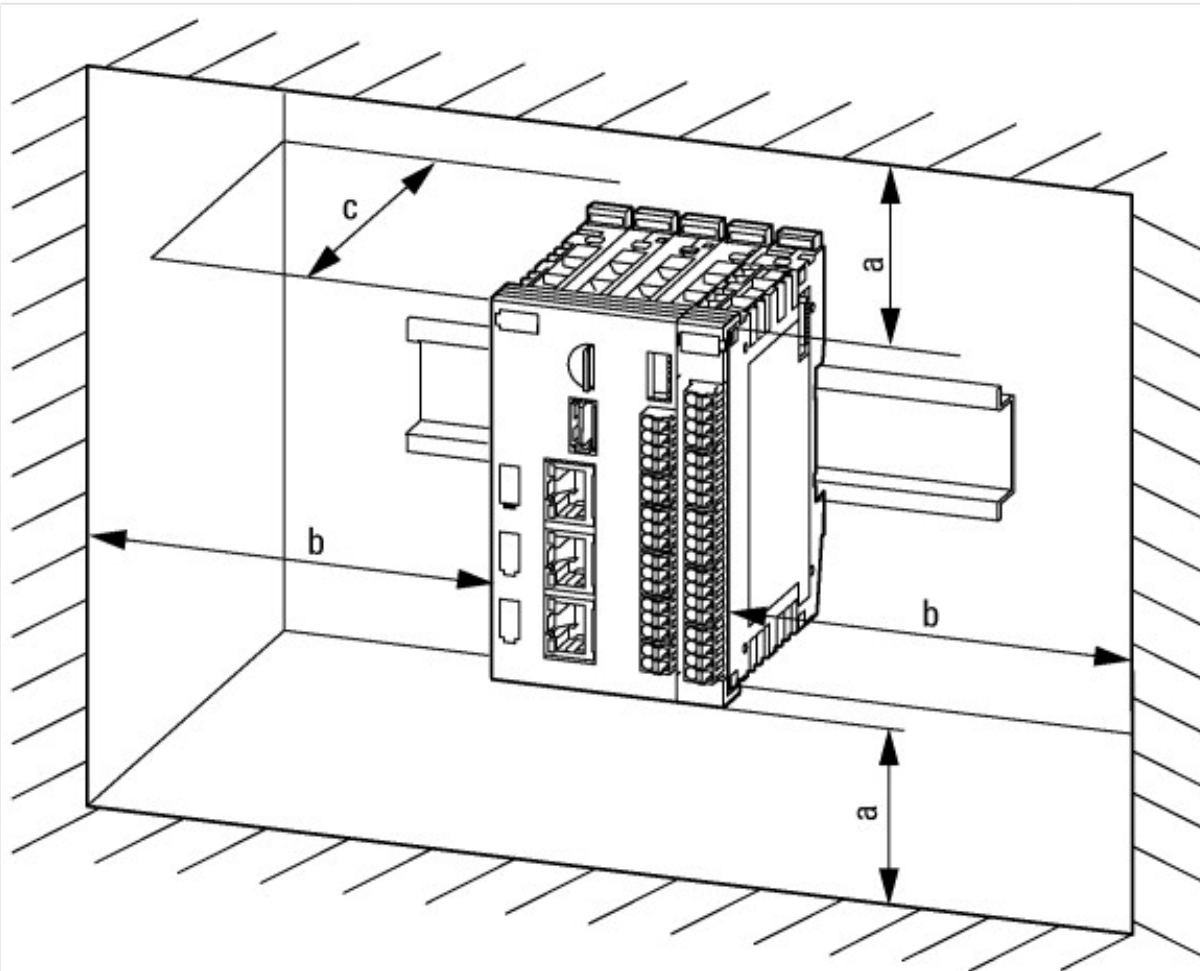

108.7 mm (4.28") x 54.3 mm (2.13") x 80.3 mm (3.16")

Additional product information (links)

assembly instructions XC-303-... (IL050018ZU)

assembly instructions XC-303-... (IL050018ZU) https://es-assets.eaton.com/DOCUMENTATION/AWA_INSTRUCTIONS/IL050018ZU2018_02.pdf

manual modular control XC300 (MN050005)

Modularsteuerung XC300 – Handbuch (MN050005) - Deutsch https://es-assets.eaton.com/DOCUMENTATION/AWB_MANUALS/MN050005_DE.pdf

manual modular control XC300 (MN050005) - English https://es-assets.eaton.com/DOCUMENTATION/AWB_MANUALS/MN050005_EN.pdf

Product overview (WEB) <http://www.eaton.eu/xc>