

Product Data Sheet

9295414810  
VKS0154XULCS  
DV6248 TD

**ebmpapst**

The engineer's choice



DV6248 TD

INDEX

**1 General ..... 3**

**2 Mechanics ..... 3**

2.1 General..... 3

2.2 Connections..... 3

**3 Operating Data ..... 4**

3.1 Electrical Operating Data ..... 4

3.2 Electrical Features ..... 6

3.3 Aerodynamics ..... 6

3.4 Sound Data..... 7

**4 Environment..... 7**

4.1 General..... 7

4.2 Climatic Requirements ..... 7

**5 Safety..... 8**

5.1 Electrical Safety ..... 8

5.2 Approval Tests ..... 8

**6 Reliability..... 8**

6.1 General..... 8

1 General

Fan type	Mixed-flow fan	
Rotating direction looking at rotor	Counterclockwise	
Airflow direction	Air outlet over struts	
Bearing system	Ball bearing	
Mounting position - shaft	Any	

2 Mechanics

2.1 General

Depth	51,0 mm	
Diameter	172,0 mm	
Mass	0,820 kg	
Housing material	Metal	
Impeller material	Plastic	
Max. torque when mounted across both mounting flanges	Wire outlet corner: 180 Ncm Remaining corners: 180 Ncm	
Screw size	ISO 4762 - M4 degreased, without an additional brace and without washer	

2.2 Connections

Electrical connection	Wires	
Lead wire length	L = 365 mm	
Tolerance	+ - 10,0 mm	
Tube length	S = 15 mm	
Tolerance	+ - 3,0 mm	
Wire size (AWG)	22	
Insulation diameter	1,70 mm	

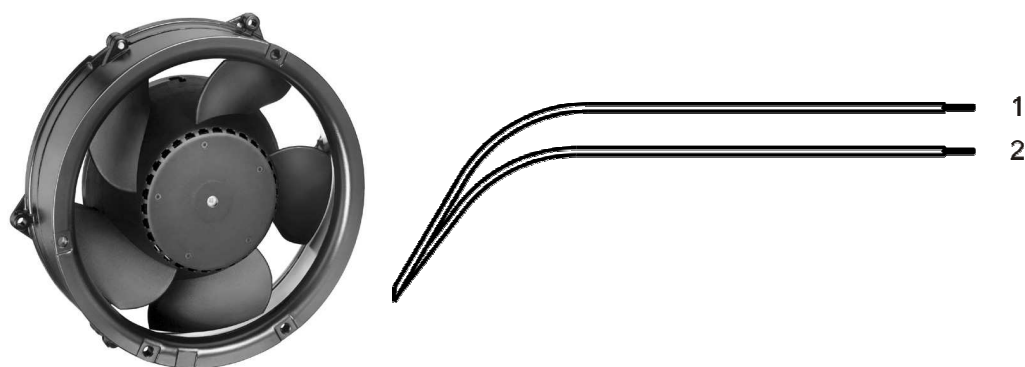

Wire	Color	Operation
1	red	+ UB
2	blue	- GND

### 3 Operating Data

#### 3.1 Electrical Operating Data

Measurement conditions: Normal air density = 1,2 kg/m<sup>3</sup>; Temperature 23°C +/- 3°C; Motor axis horizontal; warm-up time before measuring 5 minutes (unless otherwise specified). In the intake and outlet area should not be any solid obstruction within 0,5 m.

$\Delta p = 0$ : corresp. to free air flow (see chapter aerodynamics)  
 I: corresp. to arithm. mean current value

Features	Condition	Symbol	Values		
Voltage range		U	40 V		55,0 V
Nominal voltage		U <sub>N</sub>		48,0 V	
Power consumption	$\Delta p = 0$	P	68 W	87 W	85,0 W
Tolerance	0010		+/- 15 %	+/- 15,0 %	+/- 15,0 %
Current consumption	$\Delta p = 0$	I	1.750 mA	1.800 mA	1.700 mA
Tolerance	0010		+/- 15,0 %	+/- 15,0 %	+/- 15,0 %
Speed	$\Delta p = 0$	n	5.000 1/min	5.500 1/min	5.530 1/min
Tolerance	0010		+/- 10,0 %	+/- 10,0 %	+/- 10,0 %

#### Motor testing

The motor testing relates to a fan, operating with horizontal shaft, at free air flow. It is possible to run this motor in an uncontrolled state. For some testings the motor may set in a test cycle by connecting to a voltage follower as below mentioned.

#### Voltage graph to start the test cycle

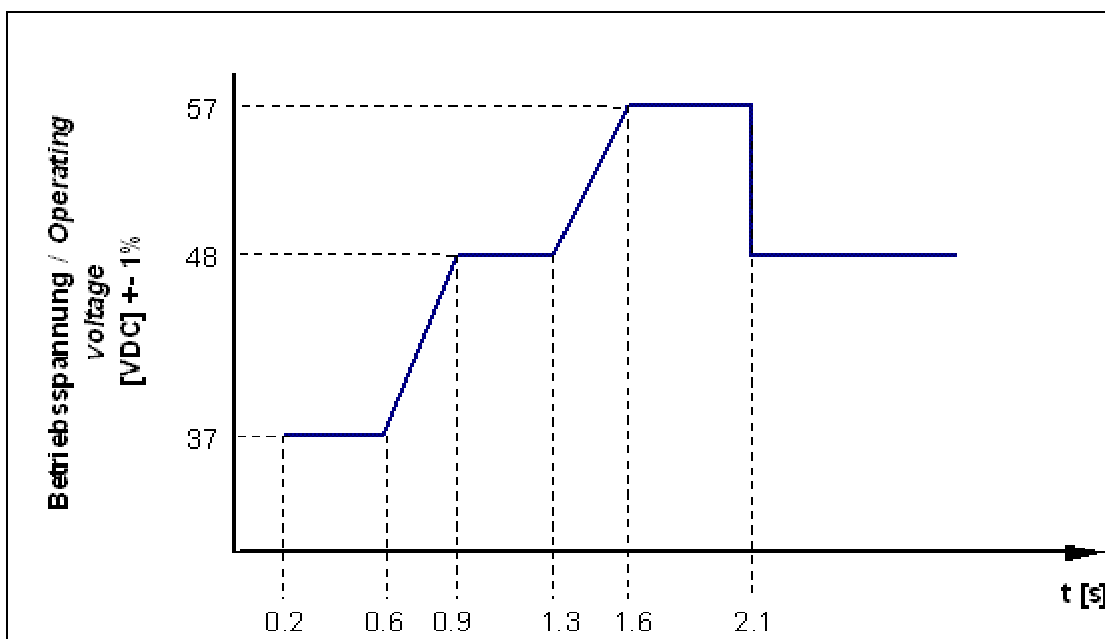

Speed graph after starting the test cycle

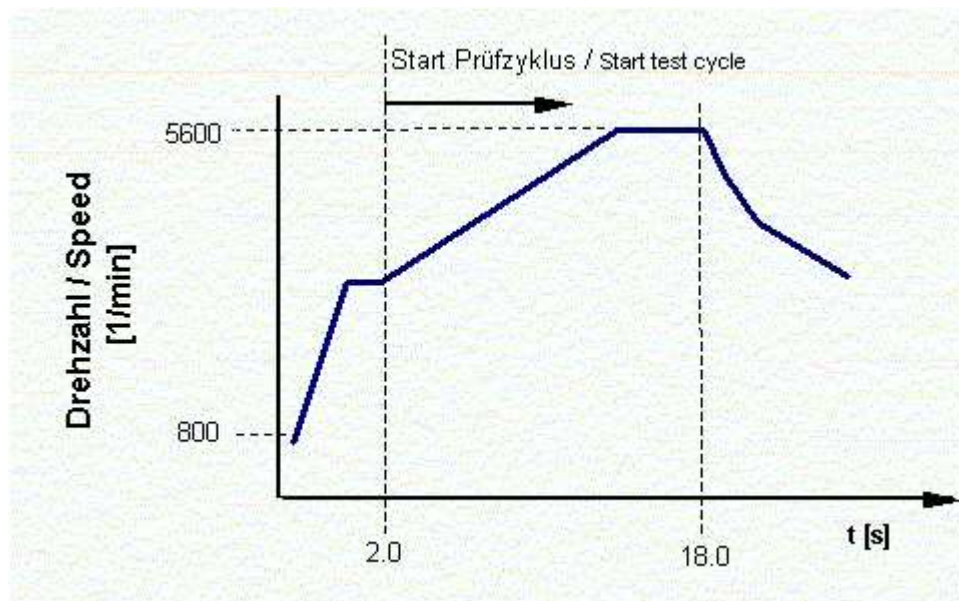

Voltage	48,0 V
Power consumption	93,6 W
Tolerance	+ - 15,0 %
Current consumption	1.950 mA
Tolerance	+ - 15,0 %
Speed	5.600 1/min
Tolerance	+ - 7,5 %

3.2 Electrical Features

Electronic function	None	
Reversed polarity protection	Rectifying diode	
Max. residual current at $U_N$	$I_F \leq 20 \text{ mA}$	
Locked rotor protection	Auto restart	
Locked rotor current at $U_N$	$I_{block}$	
Clock signal at locked rotor	$t_3 / t_4$ typical: 1,0 s / 3,1 s	

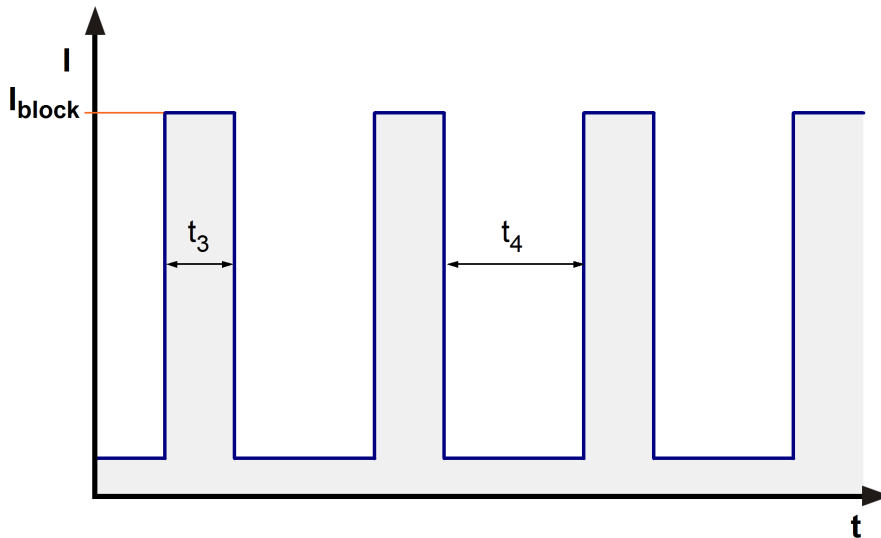

Internal Fuse:  
Littlefuse NANO2(R) FUSE; Very fast acting 451 Series; 3 A (Art.-Nr.: 451003)

3.3 Aerodynamics

Measurement conditions: Measured with a double chamber intake rig acc. to DIN EN ISO 5801.  
Normal air density = 1,2 kg/m<sup>3</sup>; Temperature 23°C +/- 3°C;  
In the intake and outlet area should not be any solid obstruction within 0,5 m. Motor shaft horizontal.  
The information is only valid under the specified test conditions and may be changed by the installation conditions. If there are deviations from the standard test conditions, the characteristic values must be checked under the installed conditions.

a.) Operation condition:

5.530 1/min at free air flow

Max. free-air flow ( $\Delta p = 0 / \dot{V} = \text{max.}$ )	680,0 m <sup>3</sup> /h	
Max. static pressure ( $\Delta p = \text{max.} / \dot{V} = 0$ )	620 Pa	

### 3.4 Sound Data

Measurement conditions: Sound pressure level: 1 meter distance between microphone and the air intake.  
Sound power level: Acc. to DIN 45635 part 38 (ISO 10302)  
Measured in a semianchoic chamber with a background noise level of  $L_p(A) < 5 \text{ dB}(A)$   
For further measurement conditions see chapter aerodynamics.

a.) Operation condition:

5.530 1/min at free air flow

Optimal operating point	460,0 m <sup>3</sup> /h @ 233 Pa	
Sound power level at the optimal operating point	8,1 bel(A)	
Sound pressure level at free air flow, measured in rubber bands	70,0 dB(A)	

## 4 Environment

### 4.1 General

Min. permitted ambient temperature TU min.	-20 °C	
Max. permitted ambient temperature TU max.	60 °C	
Min. permitted storage temperature TL min.	-40 °C	
Max. permitted storage temperature TL max.	80 °C	

### 4.2 Climatic Requirements

Humidity requirements	humid heat, constant; according to DIN EN 60068-2-78, 14 days	
Water exposure	None	
Dust requirements	None	
Salt fog requirements	None	

Permitted application area:

The product is intended for use in sheltered rooms with controlled temperature and controlled humidity. Directly exposure to water must be avoided.

Pollution degree 1 (according DIN EN 60664-1)

There is either no pollution or it occurs only dry, non-conductive pollution. The pollution has no negative impact.

Please require severity levels and specification parameters from the responsible development departments.

## 5 Safety

### 5.1 Electrical Safety

Dielectric strength DIN EN 60950 (VDE 0805) and DIN EN 60335 (VDE 0700) A.) Type test Measuring conditions: After 48h of storage at 95% R.H. and 25°C. No arcing or breakdown is allowed! All connections together to ground.	500 VAC / 1 Min.	
B.) Routine test Measuring conditions: At indoor climate. No arcing or breakdown is allowed! All connections together to ground.	850 VDC / 1 Sec.	
Isolation resistance Measuring conditions: After 48h of storage at 95% R.H. and 25°C measured with U=500 VDC for 1 min.	RI > 10 MOhm	
Clearance / creepage distance	1,0 mm / 1,5 mm	
Protection class	III	

### 5.2 Approval Tests

CE	EC Declaration of Conformity	Yes
EAC	Eurasian Conformity	Yes
UL	Underwriters Laboratories	Yes / UL507, Electric Fans E38324
VDE	Association for Electrical, Electronic and Information Technologies	Yes / Approval acc. to EN 60950 (VDE 0805) - Information technology equipment
CSA	Canadian Standards Association	Yes / C22.2 No. 113 Fans and Ventilators
CCC	China Compulsory Certification	Yes / GB 12350 Safety Requirements for small Power Motors

## 6 Reliability

### 6.1 General

Life expectancy L10 at TU = 40 °C	65.000 h	
Life expectancy L10 at TU max.	40.000 h	



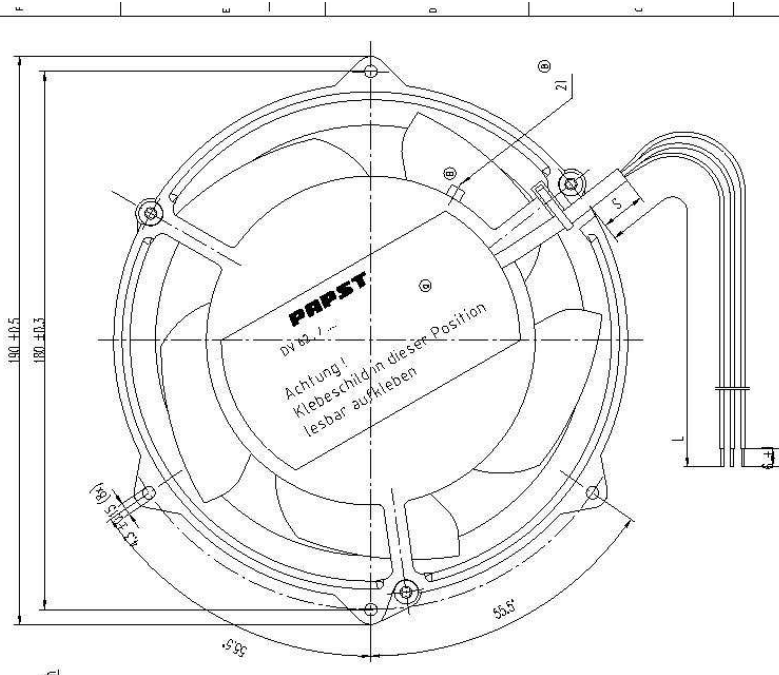

Anzahl und Länge der Litzen siehe Bv-BL 1

2) nur bei "1" Ausführung  
 Ⓞ INTIC auf Leiterplatte

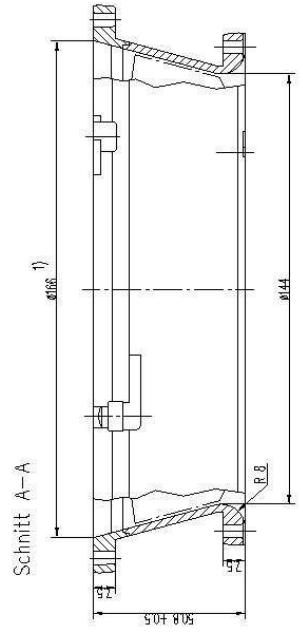
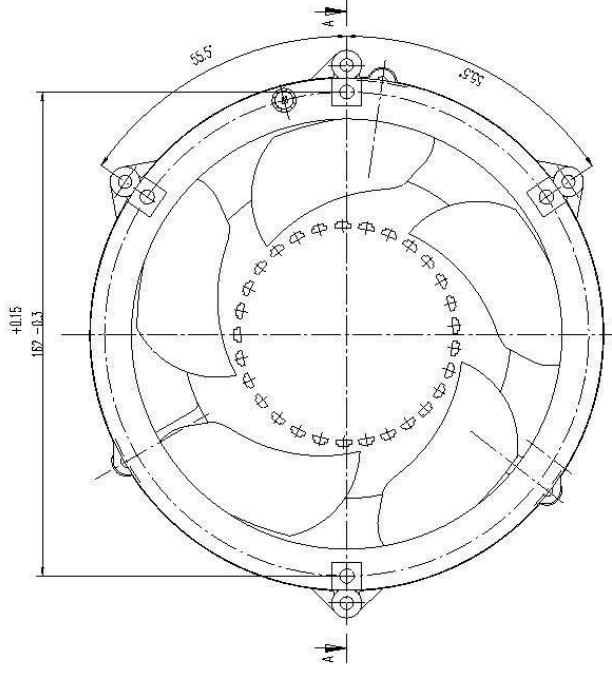
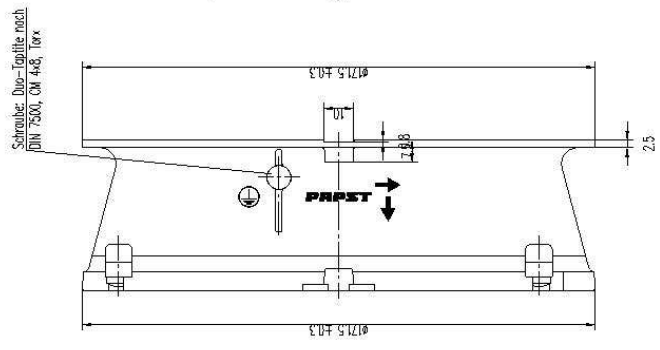

1) Durchmesser für Montagewand  
 Axialspiel: mit Feder spielfrei verspannt

Seitensicht nach DIN ISO 1030  
 Drawing of this document and printing it is allowed only for reproduction of the parts of the design which are necessary for the assembly of the part. The copyright in this drawing remains with the designer. No part of this drawing may be reproduced or transmitted in any form or by any means, electronic, mechanical, photocopying, recording, or by any information storage and retrieval system, without express written permission of the copyright owner.

Bezeichnung: DIN 7167		Artikel	
allgemeine Bezeichnung:		Herfab	
Bestell-Nr.	Name	Zug-Nr.	
Intic	Zug-Nr.	Ev.209:	
Spezifisch zur Verwendung im Original		Ev.209:	
an		A2	