

Product Data Sheet

9595420413

VBS0225XULDS

RER225-

63/18/2TDMLO

ebmpapst

engineering a better life



RER225-63/18/2TDMLO

INDEX

- 1 General 3**
- 2 Mechanics 3**
 - 2.1 General 3
 - 2.2 Connections 3
- 3 Operating Data 5**
 - 3.1 Electrical Interface - Input 5
 - 3.2 Electrical Operating Data 7
 - 3.3 Electrical Interface - Output 8
 - 3.4 Electrical Features 9
 - 3.5 Aerodynamics 10
 - 3.6 Sound Data 11
- 4 Environment 11**
 - 4.1 General 11
 - 4.2 Climatic Requirements 11
 - 4.3 EMC 11
- 5 Safety 13**
 - 5.1 Electrical Safety 13
 - 5.2 Approval Tests 13
- 6 Reliability 13**
 - 6.1 General 13

1 General

Fan type	Blower without chassis with intake nozzle	
Rotating direction looking at rotor	Clockwise	
Airflow direction	Air in axially, Air out radially	
Bearing system	Ball bearing	
Mounting position - shaft	Any	

Please note:

"Sensorless commutation electronic, starting at the first start may not be 100% guaranteed, automatic restart occurs."

2 Mechanics**2.1 General**

Depth	99,0 mm	
Diameter	225,0 mm	
Mass	1,027 kg	
Housing material		
Impeller material	Plastic	

2.2 Connections

Electrical connection	Wires	
Lead wire length	L = 425 mm	
Tolerance	+ - 10,0 mm	
Tube length	S = 135 mm	
Tolerance	+ - 5,0 mm	

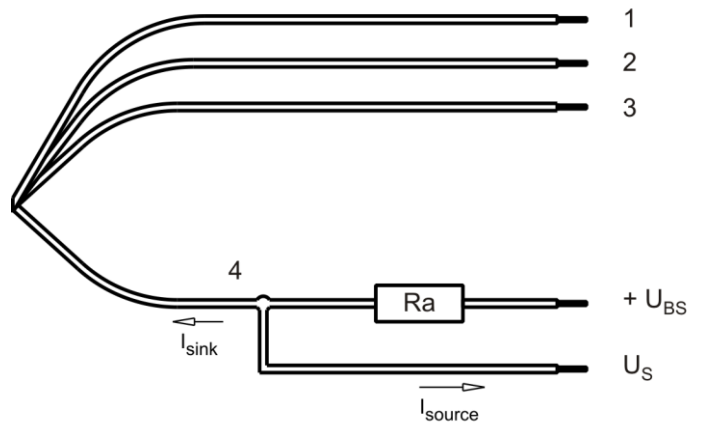

Wire	Color	Operation	Wire size	Insulation diameter
1	red	+ UB	AWG 22	1,70 mm
2	blue	- GND	AWG 22	1,70 mm
3	violet	CONTR	AWG 22	1,70 mm
4	white	Tacho	AWG 22	1,70 mm

The auxiliaries shown on the schematic diagram (which are required for the intended use) are not part of our delivery.

3 Operating Data

3.1 Electrical Interface - Input

Control input	Analog
---------------	--------

Features

PWM - Frequency	1 kHz - 10 kHz typical: 2 kHz
Input voltage range	0 V - 10 V

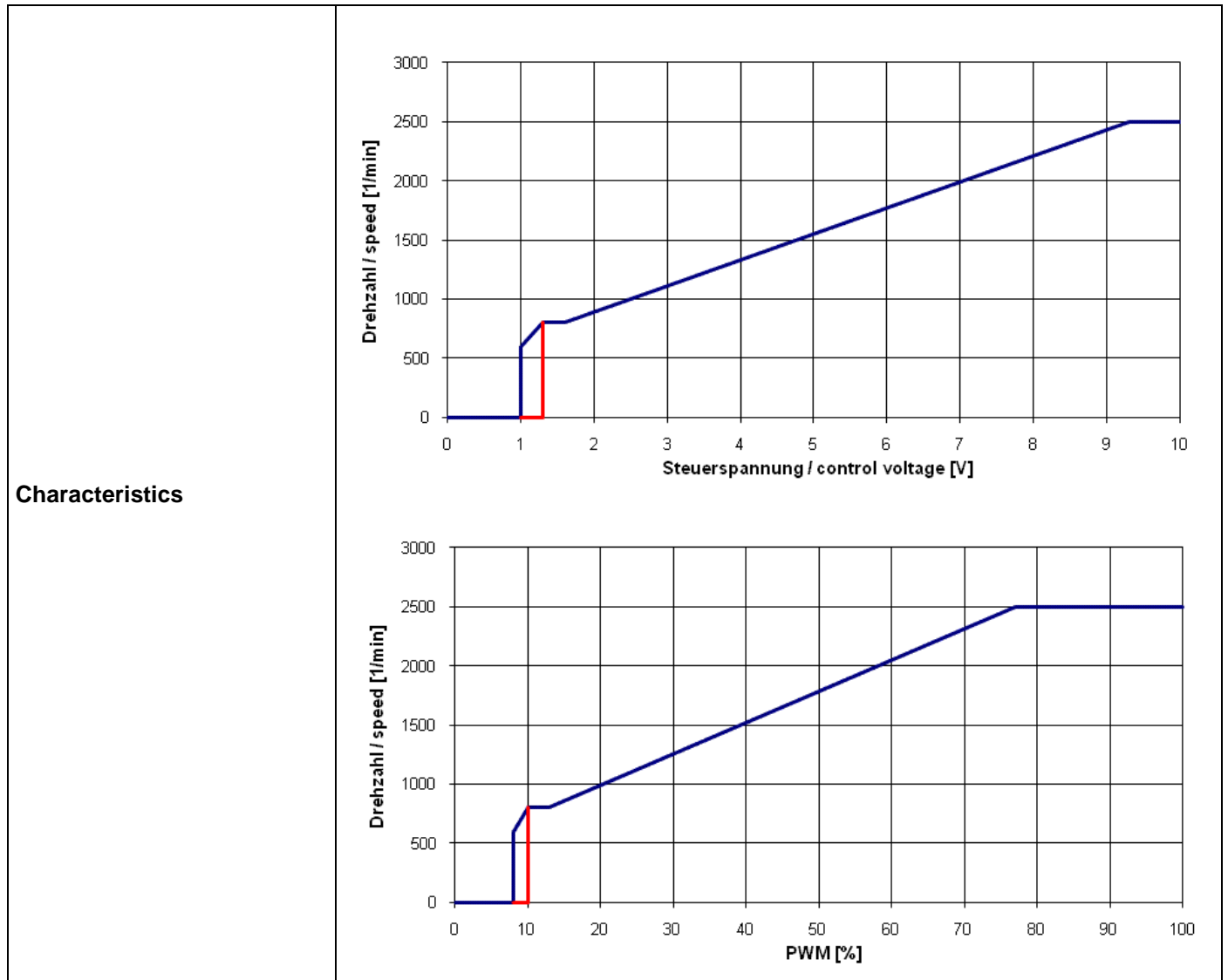

Schematics

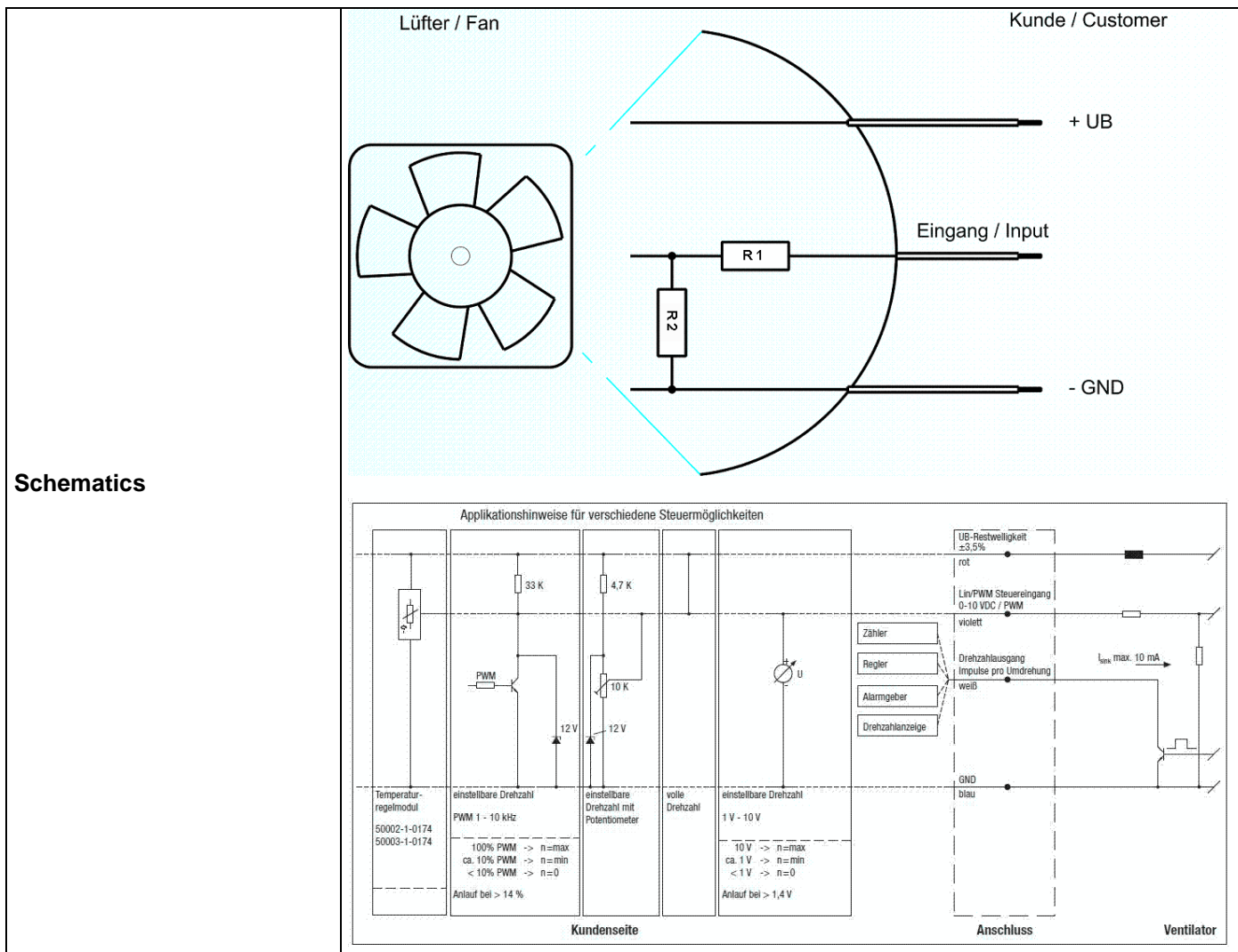

Input voltage divider:

R1 = 47 kOhm

R2 = 36 kOhm

For protection: There is parallel to R2 a 5,1 V Z-Diode

Speed control:

By pulse-width modulation (PWM) 0 ... 100%
 with switching transistor in emitter circuit and collector resistance to 12 V
 Frequency = 2 kHz (1 - 10 kHz)

Information to the curve PWM:

- 0% - <10% PWM: 0 1/min
- 10% PWM: 800 1/min (Fan on, coming from 0% PWM)
- 10% - 13% PWM: 800 1/min (corresponding to min. speed)
- 13% - 78% PWM: linear increasing curve
- 78% - 100% PWM: 2500 1/min (corresponding to max. speed)
- 10% - >8% PWM: linear decreasing curve (coming from 100% PWM)
- 8% PWM: 600 1/min or 0 1/min (Fan off, coming from 100% PWM)

oder:

Speed control:

By analog voltage 0 - 10 V

Information to the curve analog:

0 V - < 1,3 V:	0 1/min
1,3 V:	800 1/min (Fan on, coming from von 0 V)
1,3 V - 1,6 V:	800 1/min (corresponding to min. speed)
1,6 V - 9,4 V:	linear increasing curve
9,4 V - 10 V:	2500 1/min (corresponding to max. speed)
1,3 V - > 1,0 V:	linear decreasing curve (coming from 10 V)
1,0 V:	600 1/min or 0 1/min (Fan off, coming from 10 V)

All values are measured in the housing!

Fan doesn't have a sensor break detection!

3.2 Electrical Operating Data

Measurement conditions: Normal air density = 1,2 kg/m³; Temperature 23°C +/- 3°C; Motor axis horizontal; warm-up time before measuring 5 minutes (unless otherwise specified).
In the intake and outlet area should not be any solid obstruction within 0,5 m.

Measurement setup:	Measured between two steel plates
Steel plate:	266 mm x 266 mm
Intake nozzle:	D: 146 mm; R: 25 mm
Distance between bottom and top plate:	123,5 mm
Overlapping impeller / nozzle:	2 mm

$\Delta p = 0$: corresp. to free air flow (see chapter aerodynamics)

I: corresp. to arithm. mean current value

Name	Condition
U Contr. 0001	U Contr.: 10 V

Fan has no sensor break detection (**open control input = speed 0**)

Features	Condition	Symbol	Values		
Voltage range		U	36 V		72 V
Nominal voltage		U _N		48 V	
Power consumption	$\Delta p = 0$	P	77 W	82 W	82 W
Tolerance	U Contr. 0010		+/- 10,0 %	+/- 10,0 %	+/- 10,0 %
Current consumption	$\Delta p = 0$	I	2.150 mA	1.700 mA	1.100 mA
Tolerance	U Contr.0010		+/- 10,0 %	+/- 10,0 %	+/- 10,0 %
Speed	$\Delta p = 0$	n	2.500 1/min	2.500 1/min	2.500 1/min
Tolerance	U Contr. 0010		+/- 7,5 %	+/- 7,5 %	+/- 7,5 %

3.3 Electrical Interface - Output

Tacho type	/2 (open collector)
------------	---------------------

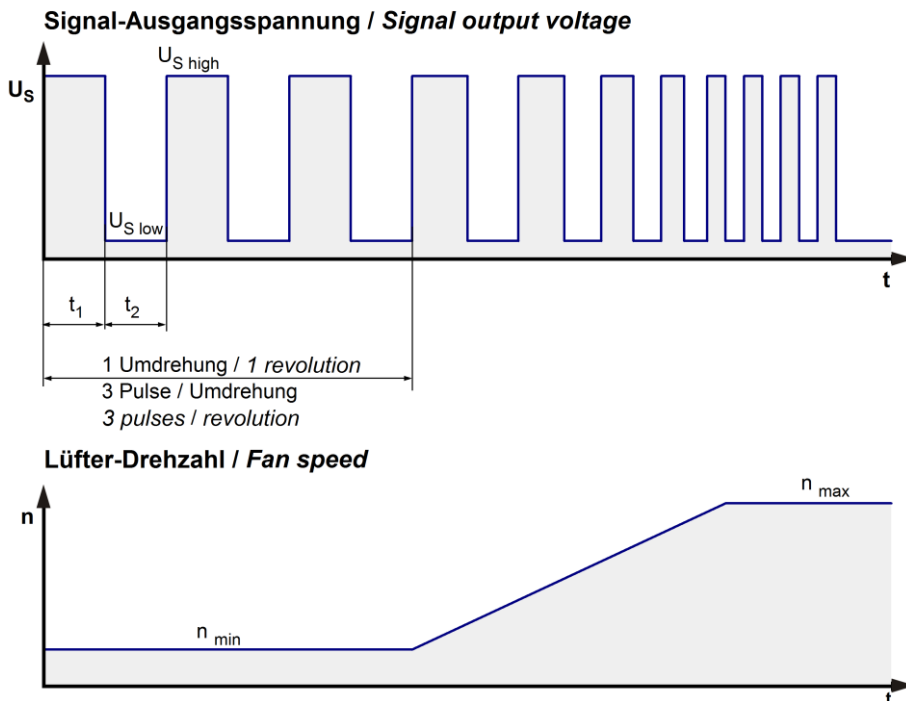

$$R_a = \frac{U_{BS} - U_{S\ low}}{I_{sink}}$$

Lüfter / Fan Kunde / Customer

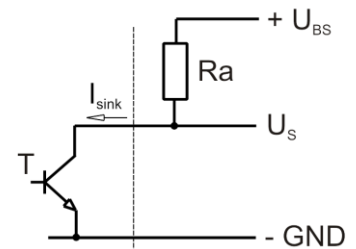

Features	Note	Values
Tacho operating voltage	U_{BS}	$\leq 60,0\ V$
Tacho signal Low	$U_{S\ low}$	$\leq 0,4\ V$
Tacho signal High	$U_{S\ high}$	$\leq 60,0\ V$
Maximum sink current	I_{sink}	$\leq 20\ mA$
Maximum source current		$0\ mA$
External resistor	External resistor R_a from U_{BS} to U_S required. All voltages measured to GND.	
Tacho frequency	$(3 \times n) / 60$	125 Hz
Tacho isolated from motor	No	
Slew rate		$\Rightarrow 0,5\ V/\mu s$

n = revolutions per minute (1/min)

Please note:

At zero speed the tacho signal is at a static HIGH. It will be also HIGH when the fan is still spinning, but the speed control signal is set to zero speed already.

The tacho signal is only activated after the start-up is completed.

3.4 Electrical Features

Electronic function	Speed-Controlled	
Reversed polarity protection	P-CH FET	
Max. residual current at U_N	$I_F \leq 5 \text{ mA}$	
Locked rotor protection	Auto restart	
Locked rotor current at U_N	I_{block} approx. 3.000 mA	
Clock signal at locked rotor	t_3 / t_4 typical: 7 s / 10,0 s	

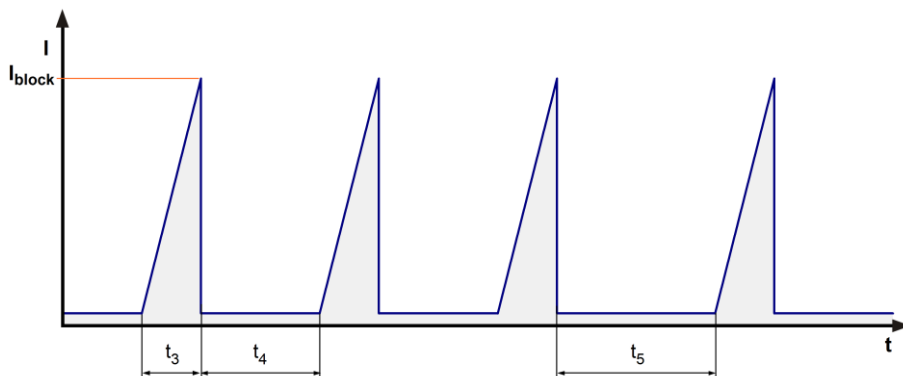

Locked rotor signal t_5 :

After 2 failed start-ups there is an extended timeout of 50 s.

3.5 Aerodynamics

Measurement conditions: Measured with a double chamber intake rig acc. to DIN EN ISO 5801. Normal air density = 1,2 kg/m³; Temperature 23°C +/- 3°C; In the intake and outlet area should not be any solid obstruction within 0,5 m. Motor shaft horizontal.

The information is only valid under the specified test conditions and may be changed by the installation conditions. If there are deviations from the standard test conditions, the characteristic values must be checked under the installed conditions. Power consumption of the fan motor when operating at normal voltage is shown. Depending on the operating conditions of the application, the power input may be higher.

Measurement setup:	Measured between two steel plates
Steel plate:	266 mm x 266 mm
Intake nozzle:	D: 146 mm; R: 25 mm
Distance between bottom and top plate:	123,5 mm
Overlapping impeller / nozzle:	2 mm

a.) Operation condition:

2.500 1/min at free air flow	U Contr. 10 V		
------------------------------	---------------	--	--

Max. free-air flow ($\Delta p = 0 / \dot{V} = \text{max.}$)	1.175 m ³ /h	
Max. static pressure ($\Delta p = \text{max.} / \dot{V} = 0$)	435 Pa	

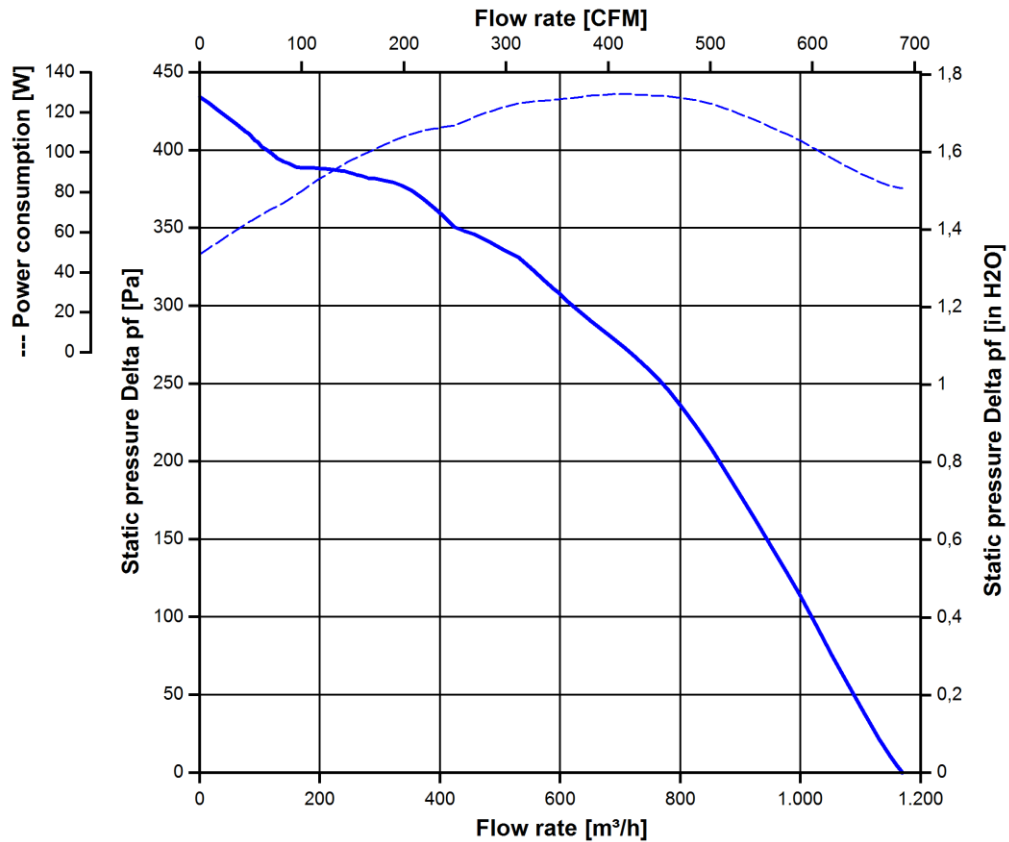

3.6 Sound Data

Measurement conditions: Sound pressure level: 1 meter distance between microphone and the air intake.
Sound power level: According to DIN 45635 Part 38 (ISO 10302)
Measured in a semianechoic chamber with a background noise level of $L_p(A) < 5 \text{ dB(A)}$
For further measurement conditions see chapter aerodynamics.

a.) Operation condition:

2.500 1/min at free air flow	U Contr. 10 V		
------------------------------	---------------	--	--

Optimal operating point	295 m ³ /h @ 260 Pa	
Sound power level at the optimal operating point	4,3 bel(A)	
Sound pressure level at free air flow, measured in rubber bands		

4 Environment

4.1 General

Min. permitted ambient temperature TU min.	-20 °C	
Max. permitted ambient temperature TU max.	55 °C	
Min. permitted storage temperature TL min.	-40 °C	
Max. permitted storage temperature TL max.	80 °C	

4.2 Climatic Requirements

Humidity requirements	humid heat, constant; according to DIN EN 60068-2-78, 14 days	
Water exposure	None	
Dust requirements	None	
Salt fog requirements	None	

Permitted application area:

The product is intended for use in sheltered rooms with controlled temperature and controlled humidity. Directly exposure to water must be avoided.

Pollution degree 1 (according DIN EN 60664-1)

There is either no pollution or it occurs only dry, non-conductive pollution. The pollution has no negative impact.

Please require severity levels and specification parameters from the responsible development departments.

4.3 EMC

Kind	Radiated Emission; 30 MHz - 1000 MHz
According	DIN EN 55032:2016-02
Check accuracy / Limit	Class B
Result	Below limit Class B

Kind	Electrostatic Discharge Immunity Test
Accordinging	DIN EN 61000-4-2:2001-12
Ceck accuracy / Limit	Contact Discharge +/- 4 kV; Air Discharge +/- 8 kV
Result	A: The monitored function operates as designed during and after exposure to a disturbance.

Kind	Electromagnetic Field Immunity Test
Accordinging	DIN EN 61000-4-3:2006-12
Ceck accuracy / Limit	10 V/m; 80 - 1000 MHz; AM; m = 0,8; f = 1 kHz; 1%; t = 3 s
Result	A: The monitored function operates as designed during and after exposure to a disturbance.

Kind	Electrical Fast Transient / Burst Immunity Test
Accordinging	DIN EN 61000-4-4:2005-07
Ceck accuracy / Limit	+/- 2 kV on Power Lines; Coupling: POS, NEG, {PE}, ALL, 5 kHz and 100 kHz; 1 min
Result	A: The monitored function operates as designed during and after exposure to a disturbance.

Kind	Immunity to Conducted Disturbances, Induced by RF-Fields
Accordinging	DIN EN 61000-4-6:2001-12
Ceck accuracy / Limit	10 Vrms; 150 kHz - 80 MHz; AM; m = 0,8; f = 1 kHz; 1%; t = 3 s
Result	A: The monitored function operates as designed during and after exposure to a disturbance.

5 Safety

5.1 Electrical Safety

Dielectric strength DIN EN 62368 and DIN EN 60335 A.) Type test Measuring conditions: After 48h of storage at 95% R.H. and 25°C. No arcing or breakdown is allowed! All connections together to ground. B.) Routine test Measuring conditions: At indoor climate. No arcing or breakdown is allowed! All connections together to ground.	1000 VAC / 1 Min. 1700 VDC / 1 Sec.	
Isolation resistance Measuring conditions: After 48h of storage at 95% R.H. and 25°C measured with U=500 VDC for 1 min.	RI > 10 MOhm	
Clearance / creepage distance	1,0 mm / 1,5 mm	
Protection class	I	

5.2 Approval Tests

CE	EC Declaration of Conformity	Yes
EAC	Eurasian Conformity	Yes
UL	Underwriters Laboratories	Yes
VDE	Association for Electrical, Electronic and Information Technologies	Yes
CSA	Canadian Standards Association	Yes
CCC	China Compulsory Certification	Yes

6 Reliability

6.1 General

Life expectancy L10 at TU = 40 °C	55.000 h	
Life expectancy L10 at TU max.	40.000 h	
Life expectancy L10 acc. to IPC 9591 at TU = 40 °C	92.500 h	

The reproduction, distribution and utilization of this document as well as the communication of its contents to others without express authorization is prohibited. Offenders will be held liable for the payment of damages. All rights reserved in the event of the grant of a patent, utility model or design. Refer to protection notice ISO 18016.

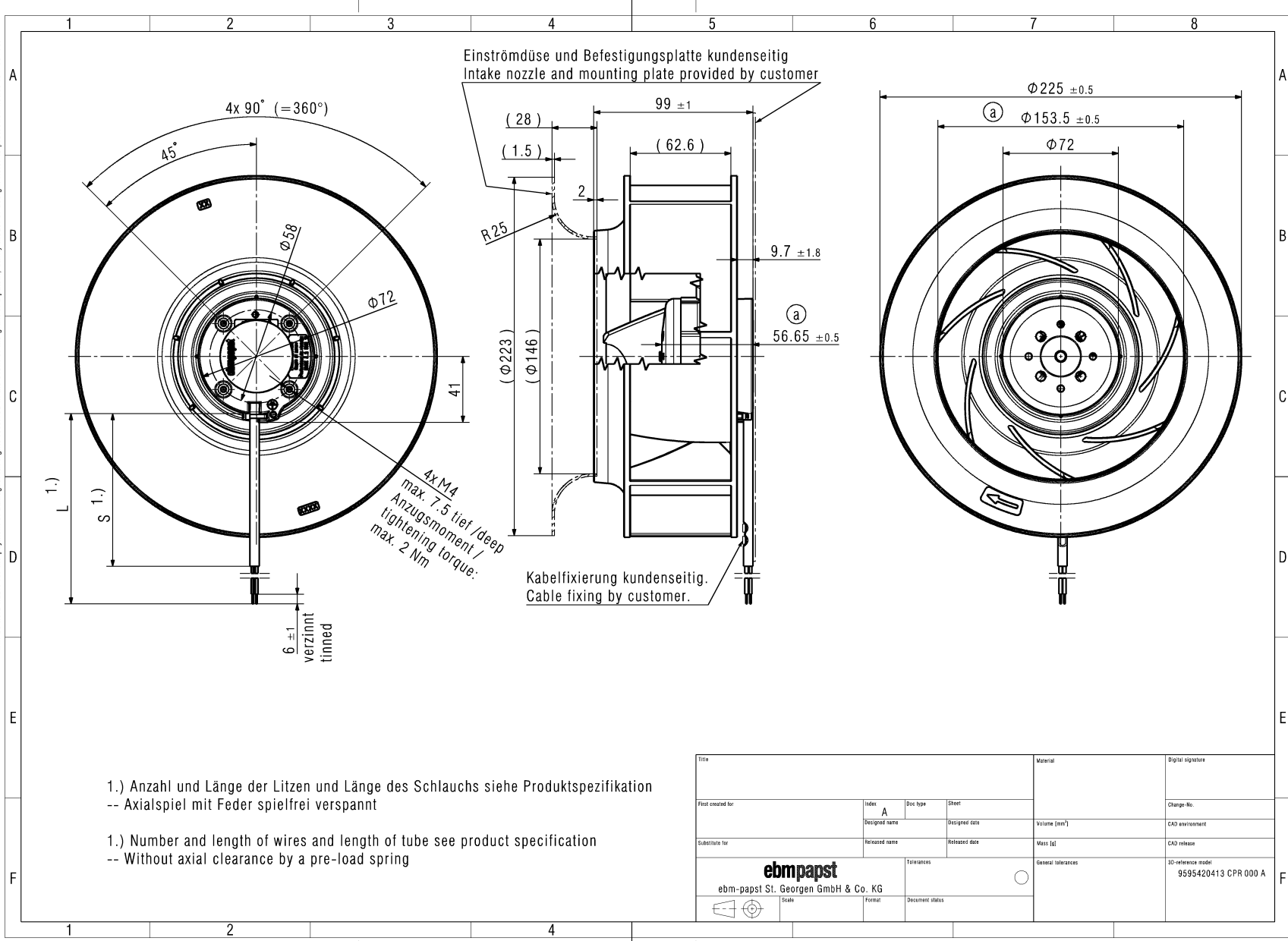

Einströmdüse und Befestigungsplatte kundenseitig
Intake nozzle and mounting plate provided by customer

4x M4
max. 7.5 tief / deep
Anzugsmoment /
tightening torque:
max. 2 Nm

Kabelfixierung kundenseitig.
Cable fixing by customer.

1.) Anzahl und Länge der Litzen und Länge des Schlauchs siehe Produktspezifikation
-- Axialspiel mit Feder spielfrei verspannt

1.) Number and length of wires and length of tube see product specification
-- Without axial clearance by a pre-load spring

Title				Material		Digital signature	
First created for		Index A	Doc type	Sheet		Change-No.	
		Designed name	Designed date		Volume (m³)		CAO environment
Substitute for		Released name	Released date		Mass (g)		CAO release
ebmpapst				Tolerances		General tolerances	
ebm-papst St. Georgen GmbH & Co. KG						3D-reference model 9595420413 CPR 000 A	
Scale		Format		Document status			