

Product Data Sheet

9793510192

VCS0100XUGBS

RLF100-11/14/19

ebmpapst

Engineering a better life



RLF100-11/14/19

INDEX

- 1 General 3**
- 2 Mechanics 3**
 - 2.1 General 3
 - 2.2 Connections 3
- 3 Operating Data 4**
 - 3.1 Electrical Operating Data 4
 - 3.2 Electrical Interface - Output 5
 - 3.3 Electrical Features 6
 - 3.4 Aerodynamics 7
 - 3.5 Sound Data 8
- 4 Environment 8**
 - 4.1 General 8
 - 4.2 Climatic Requirements 8
- 5 Safety 9**
 - 5.1 Electrical Safety 9
 - 5.2 Approval Tests 9
- 6 Reliability 9**
 - 6.1 General 9

1 General

Fan type	Blower	
Rotating direction looking at rotor	Clockwise	
Airflow direction	Air in axially, Air out radially	
Bearing system	Ball bearing	
Mounting position - shaft	Any	

2 Mechanics

2.1 General

Width	127,0 mm	
Height	127,0 mm	
Depth	25,4 mm	
Mass	0,300 kg	
Housing material	Mixed	
Impeller material	Plastic	
Max. torque when mounted across both mounting flanges	Wire outlet corner: 190 Ncm Remaining corners: 190 Ncm	
Screw size	ISO 4762 - M4 degreased, without an additional brace and without washer	

2.2 Connections

Electrical connection	Wires	
Lead wire length	L = 310 mm	
Tolerance	+/- 10,0 mm	

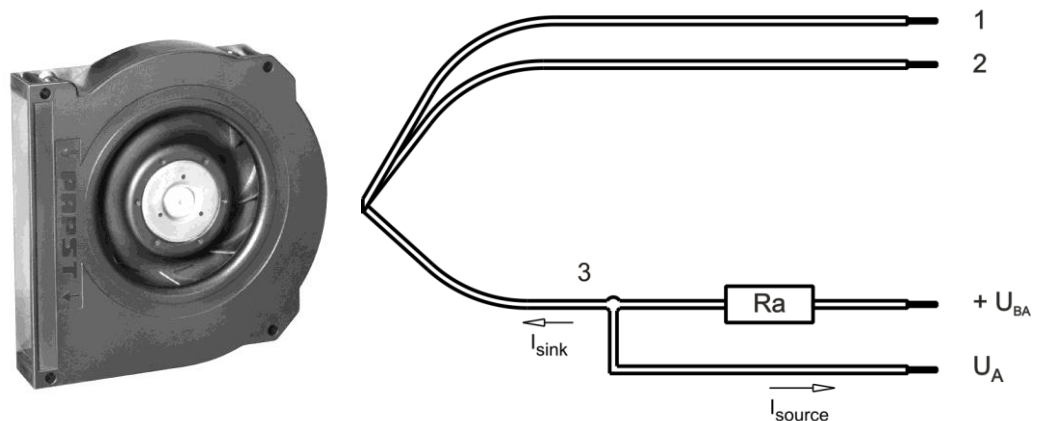

Wire	Color	Operation	Wire size	Insulation diameter
1	red	+ UB	AWG 22	1,70 mm
2	blue	- GND	AWG 22	1,70 mm
3	white	Alarm	AWG 22	1,70 mm

The auxiliaries shown on the schematic diagram (which are required for the intended use) are not part of our delivery.

3 Operating Data

3.1 Electrical Operating Data

Measurement conditions: Normal air density = 1,2 kg/m³; Temperature 23°C +/- 3°C; Motor axis horizontal; warm-up time before measuring 5 minutes (unless otherwise specified). In the intake and outlet area should not be any solid obstruction within 0,5 m.

$\Delta p = 0$: corresp. to free air flow (see chapter aerodynamics)
I: corresp. to arithm. mean current value

Features	Condition	Symbol	Values		
Voltage range		U	16,0 V		30,0 V
Nominal voltage		U _N		24,0 V	
Power consumption	$\Delta p = 0$	P	4,2 W	8,6 W	9,5 W
Tolerance	0010		+/- 17,5 %	+/- 17,5 %	+/- 17,5 %
Current consumption	$\Delta p = 0$	I	260 mA	360 mA	310 mA
Tolerance	0010		+/- 17,5 %	+/- 17,5 %	+/- 17,5 %
Speed	$\Delta p = 0$	n	3.880 1/min	5.100 1/min	5.100 1/min
Tolerance	0010		+/- 12,5 %	+/- 5,0 %	+/- 5,0 %
Starting current consumption				<= 1.850 mA	

3.2 Electrical Interface - Output

Alarm type	/19 (low = ok, open collector inverse)
------------	----------------------------------------

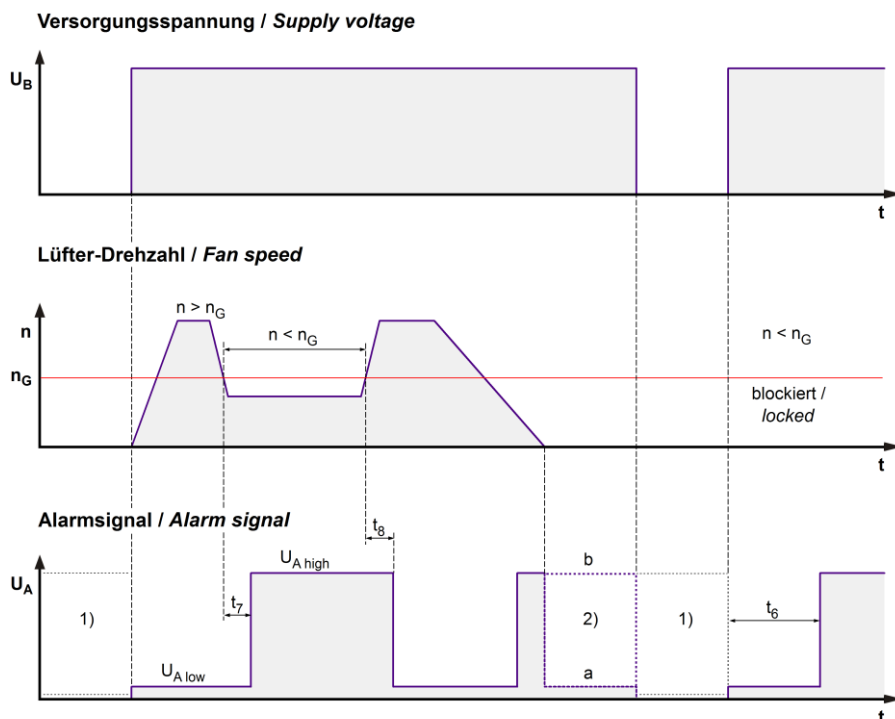

$$R_a = \frac{U_{BA} - U_{A\ low}}{I_{\ sink}}$$

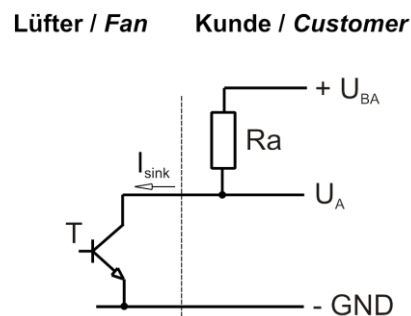

- 1) Wenn der Lüfter abgeschaltet ist, hängt der Zustand des Ausgangssignals U_A von der Kundenapplikation ab.
When the fan is powered off, the output signal U_A depends on the customer's application.
- 2) Für den gültigen Zustand (a oder b) siehe Alarmunterdrückung in der Tabelle.
For the valid condition (a or b) see alarm suppression in the table.

Features	Note	Values
Alarm operating voltage	U_{BA}	$\leq 60,0\ V$
Alarm signal Low	$U_{A\ low}$	$I_{\ sink}: 2\ mA$ $\leq 0,4\ V$
Alarm signal High	$U_{A\ high}$	$I_{\ source}: 0\ mA$ $60,0\ V$
Maximum sink current	$I_{\ sink}$	$20\ mA$
Alarm start-up delay time	t_6	$\leq 15,0\ s$
Alarm trip speed limit	n_G	$1.500\ 1/min$
Alarm at sense failure	No	
Alarm latch	No	
Alarm isolated from motor	No	

3.3 Electrical Features

Electronic function	Speed-Controlled	
Reversed polarity protection	Rectifying diode	
Max. residual current at U_N	$I_F \leq 10 \mu A$	
Locked rotor protection	Auto restart	
Locked rotor current at U_N	I_{block} approx. 1.850 mA	
Clock signal at locked rotor	t_3 / t_4 typical: 0,4 s / 20,0 s	

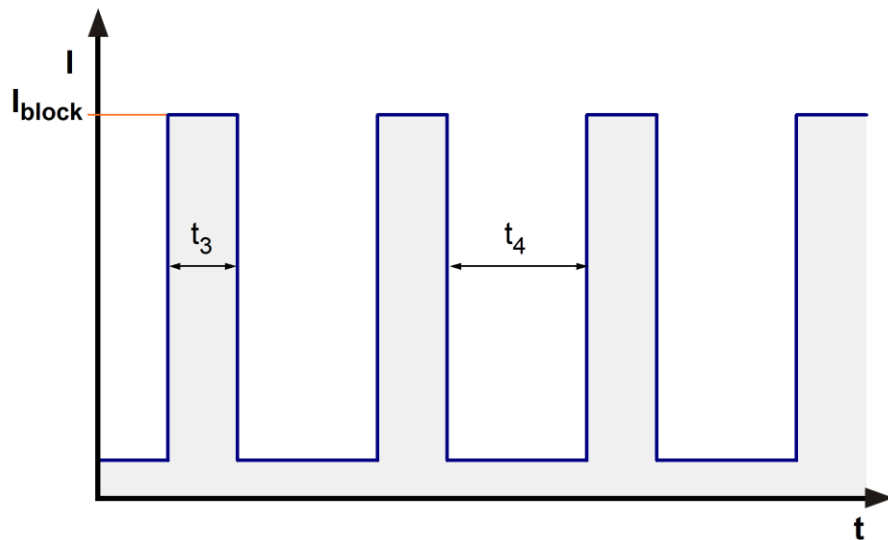

3.4 Aerodynamics

Measurement conditions: Measured with a double chamber intake rig acc. to DIN EN ISO 5801.
 Normal air density = 1,2 kg/m³; Temperature 23°C +/- 3°C;
 In the intake and outlet area should not be any solid obstruction within 0,5 m. Motor shaft horizontal.
 The information is only valid under the specified test conditions and may be changed by the installation conditions. If there are deviations from the standard test conditions, the characteristic values must be checked under the installed conditions.

a.) Operation condition:

5.100 1/min at free air flow

Max. free-air flow ($\Delta p = 0 / \dot{V} = \text{max.}$)	64,0 m ³ /h	
Max. static pressure ($\Delta p = \text{max.} / \dot{V} = 0$)	415 Pa	

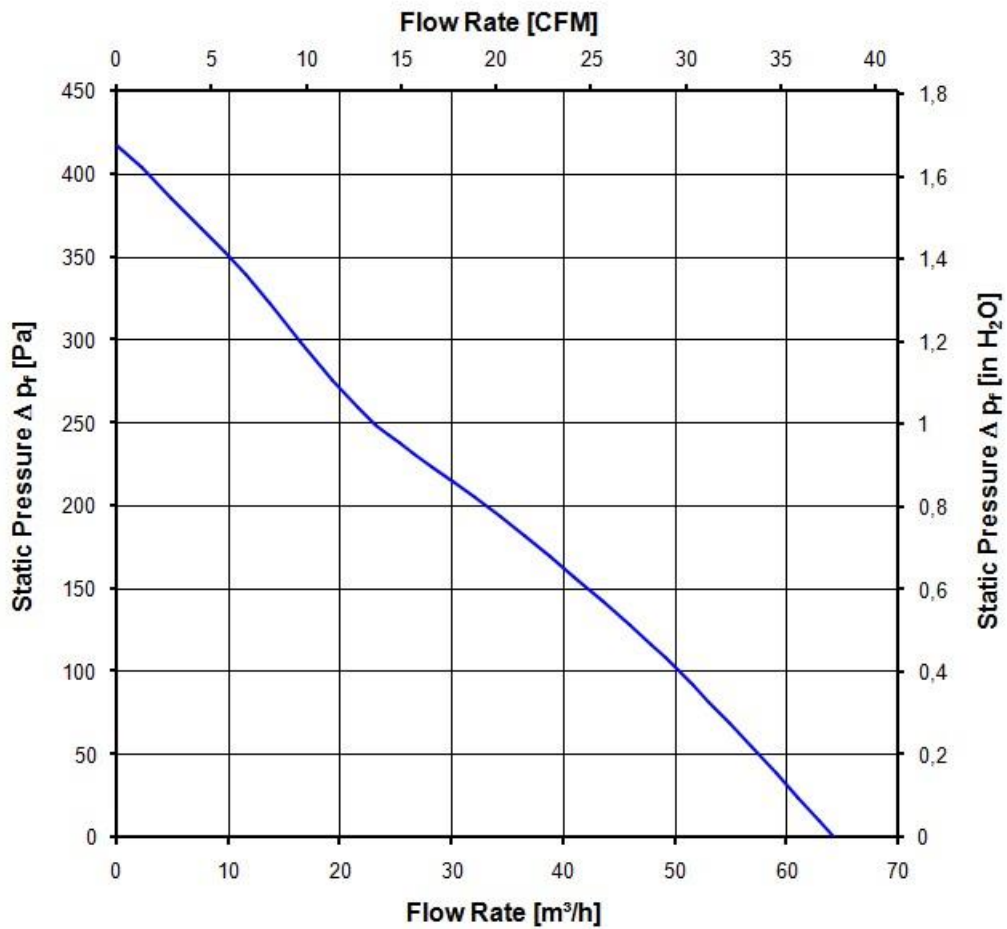

3.5 Sound Data

Measurement conditions: Sound pressure level: 1 meter distance between microphone and the air intake.
Sound power level: Acc. to DIN 45635 part 38 (ISO 10302)
Measured in a semianechoic chamber with a background noise level of $L_p(A) < 5 \text{ dB(A)}$
For further measurement conditions see chapter aerodynamics.

a.) Operation condition:

5.100 1/min at free air flow

Optimal operating point	37,0 m ³ /h @ 160 Pa	
Sound power level at the optimal operating point	6,4 bel(A)	
Sound pressure level at free air flow, measured in rubber bands		

4 Environment

4.1 General

Min. permitted ambient temperature TU min.	-20 °C	
Max. permitted ambient temperature TU max.	75 °C	
Min. permitted storage temperature TL min.	-40 °C	
Max. permitted storage temperature TL max.	80 °C	

4.2 Climatic Requirements

Humidity requirements	humid heat, constant; according to DIN EN 60068-2-78, 14 days	
Water exposure	None	
Dust requirements	None	
Salt fog requirements	None	

Permitted application area:

The product is intended for use in sheltered rooms with controlled temperature and controlled humidity. Directly exposure to water must be avoided.

Pollution degree 1 (according DIN EN 60664-1)

There is either no pollution or it occurs only dry, non-conductive pollution. The pollution has no negative impact.

Please require severity levels and specification parameters from the responsible development departments.

5 Safety**5.1 Electrical Safety**

Dielectric strength DIN EN 62368 and DIN EN 60335 A.) Type test Measuring conditions: After 48h of storage at 95% R.H. and 25°C. No arcing or breakdown is allowed! All connections together to ground. B.) Routine test Measuring conditions: At indoor climate. No arcing or breakdown is allowed! All connections together to ground.	500 VAC / 1 Min. 850 VDC / 1 Sec.	
Isolation resistance Measuring conditions: After 48h of storage at 95% R.H. and 25°C measured with U=500 VDC for 1 min.	RI > 10 MOhm	
Clearance / creepage distance	1,0 mm / 1,2 mm	
Protection class	III	

5.2 Approval Tests

CE	EC Declaration of Conformity	Yes
EAC	Eurasian Conformity	Yes
UL	Underwriters Laboratories	Yes / UL507, Electric Fans E38324
VDE	Association for Electrical, Electronic and Information Technologies	Yes / Approval acc. to EN 62368 - Audio/video, information and communication technology equipment
CSA	Canadian Standards Association	Yes / CSA audited by UL according to C22.2 No. 113 Fans and Ventilators
CCC	China Compulsory Certification	Not applicable

6 Reliability**6.1 General**

Life expectancy L10 at TU = 40 °C	80.000 h	
Life expectancy L10 at TU max.	32.500 h	
Life expectancy L10 acc. to IPC 9591 at TU = 40 °C	135.000 h	

Copying of this document and giving it to others and the use or communication of the contents thereof, are forbidden without express authority. Offenders are liable to the payment of damages. All rights are reserved in the event of the grant of a patent or the registration of a utility model or design.

Schutzzeichen nach DIN ISO 8016 beachten

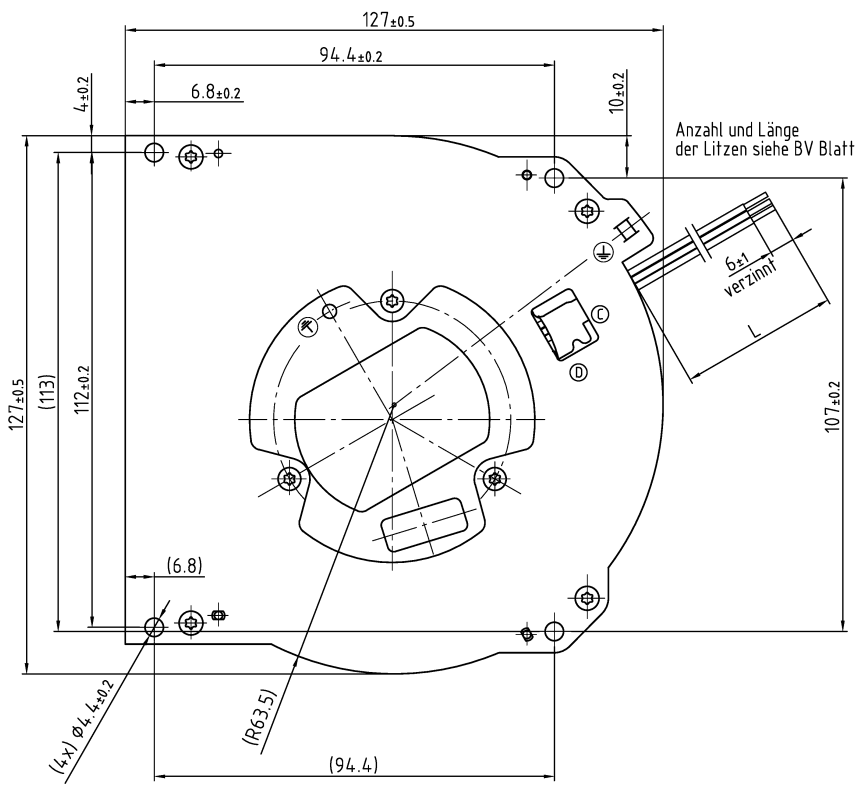

Anzahl und Länge der Litzen siehe BV Blatt 1

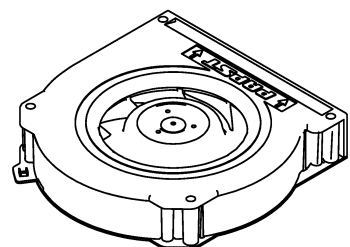
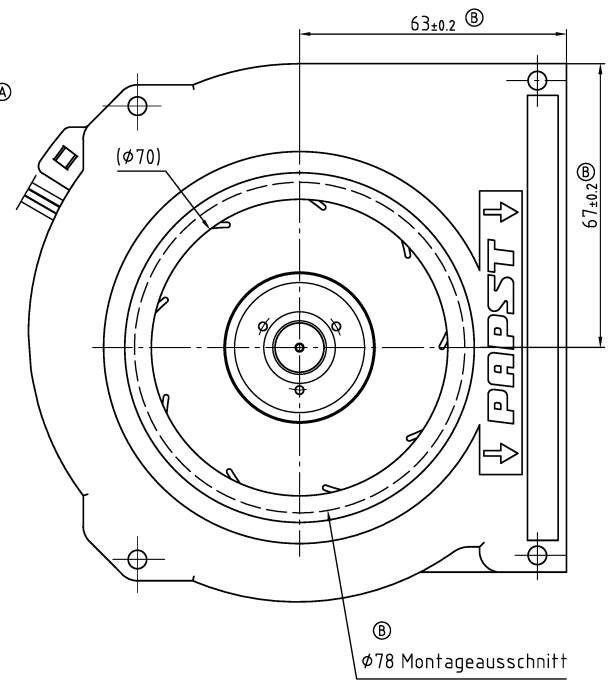
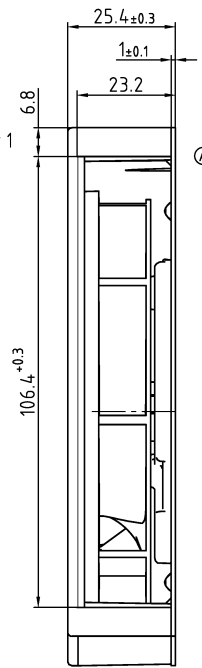

Axialspiel bei
- Kugellagerung (K): 0 (mit Federausgleich)

Tolerierung: DIN 7167			
Allgemeintoleranzen: DIN ISO 2768-mK			
		Artikel	Maßstab
Bearbeitet	Datum Name		
		Zchg.-Nr.	Blatt
Index Aend.-Nr.			
Geprüft u. zur Verwendung freigegeben von		ebm-papst St. Georgen GmbH & Co. KG	A3
am			