



Ferrites and accessories

PM 62/49
Core and accessories

Series/Type: B65684, B65685
Date: September 2006, November 2008

- To IEC 61247
- Particularly suitable for power transformers and energy storage chokes
- Delivery mode: sets

Magnetic characteristics (per set)

$$\Sigma l/A = 0.191 \text{ mm}^{-1}$$

$$l_e = 109 \text{ mm}$$

$$A_e = 570 \text{ mm}^2$$

$$A_{\min} = 470 \text{ mm}^2$$

$$V_e = 62000 \text{ mm}^3$$

Approx. weight 280 g/set

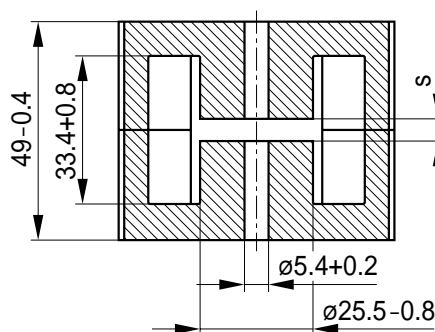
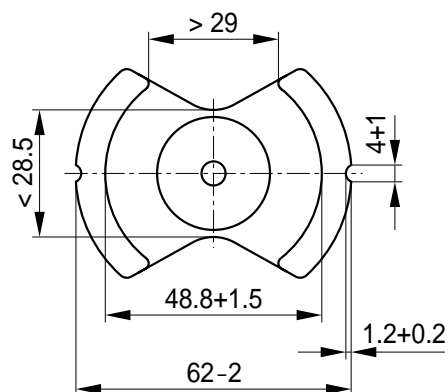

FPM0024-2

Gapped

Material	A_L value nH	s approx. mm	μ_e	Ordering code
N27	$315 \pm 3\%$	2.60	48	B65684A0315A027
	$630 \pm 3\%$	1.10	95	B65684A0630A027

Ungapped

Material	A_L value nH	μ_e	P_V W/set	Ordering code
N27	$9200 +30/-20\%$	1400	< 9.5 (200 mT, 25 kHz, 100 °C)	B65684A0000R027
N87	$9200 +30/-20\%$	1400	< 5.8 (200 mT, 100 kHz, 100 °C)	B65684A0000R087

Coil former

Material: GFR polyterephthalate (UL 94 V-0, insulation class to IEC 60085: F \geq max. operating temperature 155 °C), color code black
Valox 420-SE0® [E45329 (M)], GE PLASTICS B V

Solderability: to IEC 60068-2-20, test Ta, method 1 (aging 3): 235 °C, 2 s

Resistance to soldering heat: to IEC 60068-2-20, test Tb, method 1B: 350 °C, 3.5 s

Winding: see Data Book 2007, chapter "Processing notes, 2.1"

Pins squared in the start-of-winding area.

Also available without solder pins.

Sections	A _N mm ²	l _N mm	A _R value μΩ	Solder pins	Ordering code
1	270	120	15.4	16	B65685B1016T001
1	270	120	15.4	—	B65685A1000T001

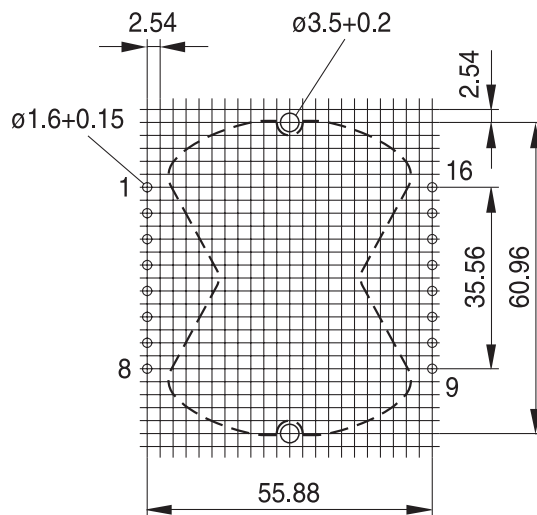
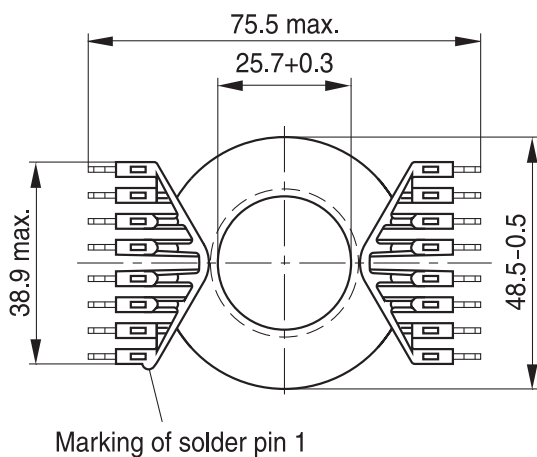

Hole arrangement
View in mounting direction

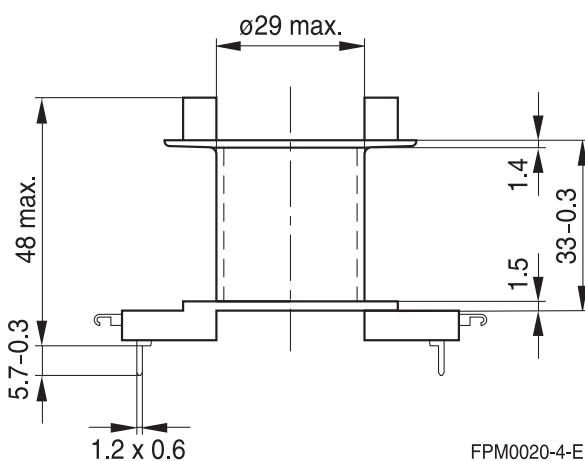

Mounting assembly

- For chassis mounting¹⁾ or printed circuit boards
- The set comprises a yoke and a base plate
- Fixing nuts M3 and washers are supplied

Yoke

- Material: Brass clamping yoke (\varnothing 2.6 mm) with thread

Base plate

- Material: Aluminum (0.6 mm)

	Ordering code
Complete mounting assembly including nuts and washers	B65685A2000X000

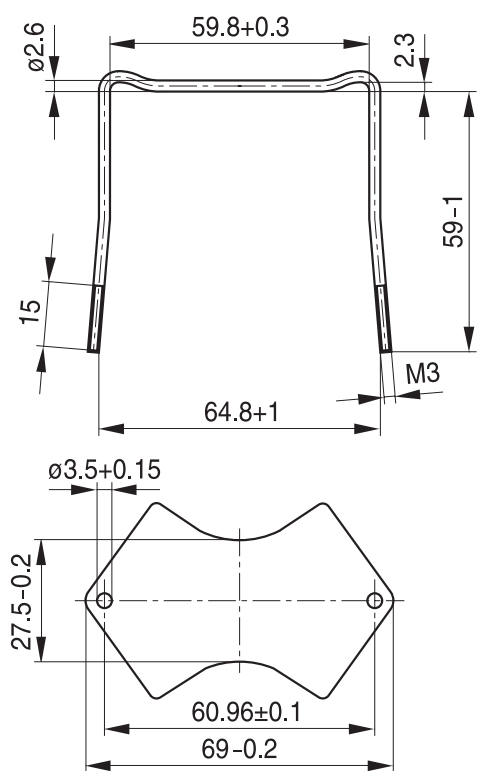

FPM0009-T

1) On a chassis the coil former must be mounted with its solder pins upward.

Mechanical stress and mounting

Ferrite cores have to meet mechanical requirements during assembling and for a growing number of applications. Since ferrites are ceramic materials one has to be aware of the special behavior under mechanical load.

As valid for any ceramic material, ferrite cores are brittle and sensitive to any shock, fast changing or tensile load. Especially high cooling rates under ultrasonic cleaning and high static or cyclic loads can cause cracks or failure of the ferrite cores.

For detailed information see Data Book 2007, chapter “General – Definitions, 8.1”.

Effects of core combination on A_L value

Stresses in the core affect not only the mechanical but also the magnetic properties. It is apparent that the initial permeability is dependent on the stress state of the core. The higher the stresses are in the core, the lower is the value for the initial permeability. Thus the embedding medium should have the greatest possible elasticity.

For detailed information see Data Book 2007, chapter “General – Definitions, 8.2”.

Heating up

Ferrites can run hot during operation at higher flux densities and higher frequencies.

NiZn-materials

The magnetic properties of NiZn-materials can change irreversible in high magnetic fields.

Processing notes

- The start of the winding process should be soft. Else the flanges may be destroyed.
- To strong winding forces may blast the flanges or squeeze the tube that the cores can no more be mounted.
- To long soldering time at high temperature (>300 °C) may effect coplanarity or pin arrangement.
- Not following the processing notes for soldering of the J-leg terminals may cause solderability problems at the transformer because of pollution with Sn oxyd of the tin bath or burned insulation of the wire. For detailed information see Data Book 2007, chapter “Processing notes, 2.2”.
- The dimensions of the hole arrangement have fixed values and should be understood as a recommendation for drilling the printed circuit board. For dimensioning the pins, the group of holes can only be seen under certain conditions, as they fit into the given hole arrangement. To avoid problems when mounting the transformer, the manufacturing tolerances for positioning the customers' drilling process must be considered by increasing the hole diameter.

Important notes

The following applies to all products named in this publication:

1. Some parts of this publication contain **statements about the suitability of our products for certain areas of application**. These statements are based on our knowledge of typical requirements that are often placed on our products in the areas of application concerned. We nevertheless expressly point out **that such statements cannot be regarded as binding statements about the suitability of our products for a particular customer application**.

As a rule, EPCOS is either unfamiliar with individual customer applications or less familiar with them than the customers themselves. For these reasons, it is always ultimately incumbent on the customer to check and decide whether an EPCOS product with the properties described in the product specification is suitable for use in a particular customer application.

2. We also point out that **in individual cases, a malfunction of electronic components or failure before the end of their usual service life cannot be completely ruled out in the current state of the art, even if they are operated as specified**. In customer applications requiring a very high level of operational safety and especially in customer applications in which the malfunction or failure of a passive electronic component could endanger human life or health (e.g. in accident prevention or life-saving systems), it must therefore be ensured by means of suitable design of the customer application or other action taken by the customer (e.g. installation of protective circuitry or redundancy) that no injury or damage is sustained by third parties in the event of malfunction or failure of a passive electronic component.
3. **The warnings, cautions and product-specific notes must be observed.**
4. In order to satisfy certain technical requirements, **some of the products described in this publication may contain substances subject to restrictions in certain jurisdictions (e.g. because they are classed as hazardous)**. Useful information on this will be found in our Material Data Sheets on the Internet (www.epcos.com/material). Should you have any more detailed questions, please contact our sales offices.
5. We constantly strive to improve our products. Consequently, **the products described in this publication may change from time to time**. The same is true of the corresponding product specifications. Please check therefore to what extent product descriptions and specifications contained in this publication are still applicable before or when you place an order.

We also **reserve the right to discontinue production and delivery of products**. Consequently, we cannot guarantee that all products named in this publication will always be available.

The aforementioned does not apply in the case of individual agreements deviating from the foregoing for customer-specific products.

6. Unless otherwise agreed in individual contracts, **all orders are subject to the current version of the “General Terms of Delivery for Products and Services in the Electrical Industry” published by the German Electrical and Electronics Industry Association (ZVEI)**.
7. The trade names EPCOS, BAOKE, Alu-X, CeraDiode, CSSP, CTVS, DSSP, MiniBlue, MKK, MLSC, MotorCap, PCC, PhaseCap, PhaseMod, SIFERRIT, SIFI, SIKOREL, SilverCap, SIMDAD, SIMID, SineFormer, SIOV, SIP5D, SIP5K, ThermoFuse, WindCap are **trademarks registered or pending** in Europe and in other countries. Further information will be found on the Internet at www.epcos.com/trademarks.