

Shock Absorber/soft type

M6, M8, M10, M14, M20, M27

New

RoHS

Improved durability

Long-term continuous operation has been realised by employing the pre-load mechanism, newly-developed oil seals.

Maximum operating cycles

10 million cycles

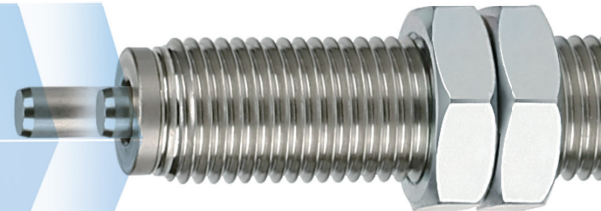

Stops transported objects softly

A smooth absorption characteristic is achieved by adopting the unique orifice mechanism to ease the impacts on conveyed objects.

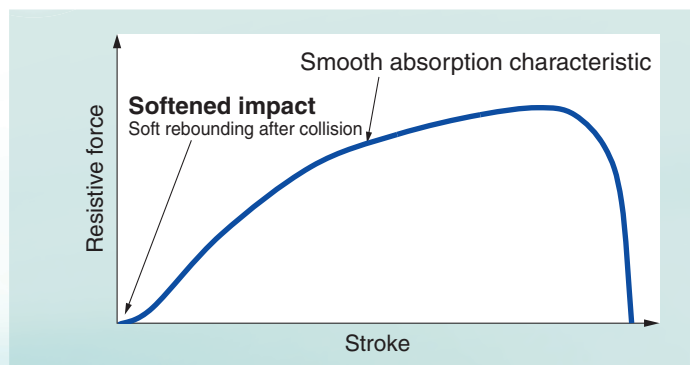

3 sizes M6, M20, M27 are added

A wider range of usage is possible by the addition of the three sizes. A type with cap is also available.

● Mounting interchangeable with the RB series.

Rich variation

Short stroke type for improving takt time for short stroke actuators.

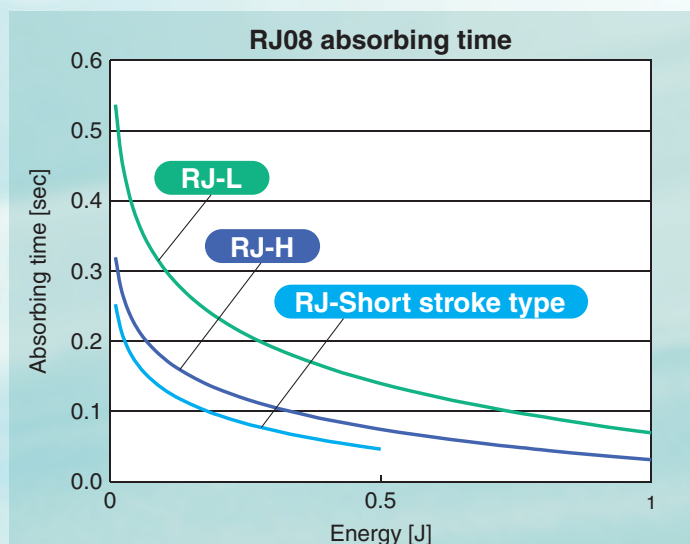

* Reference values when cylinder thrust is 157 N.
Absorbing time varies depending on cylinder collision conditions.

Series RJ

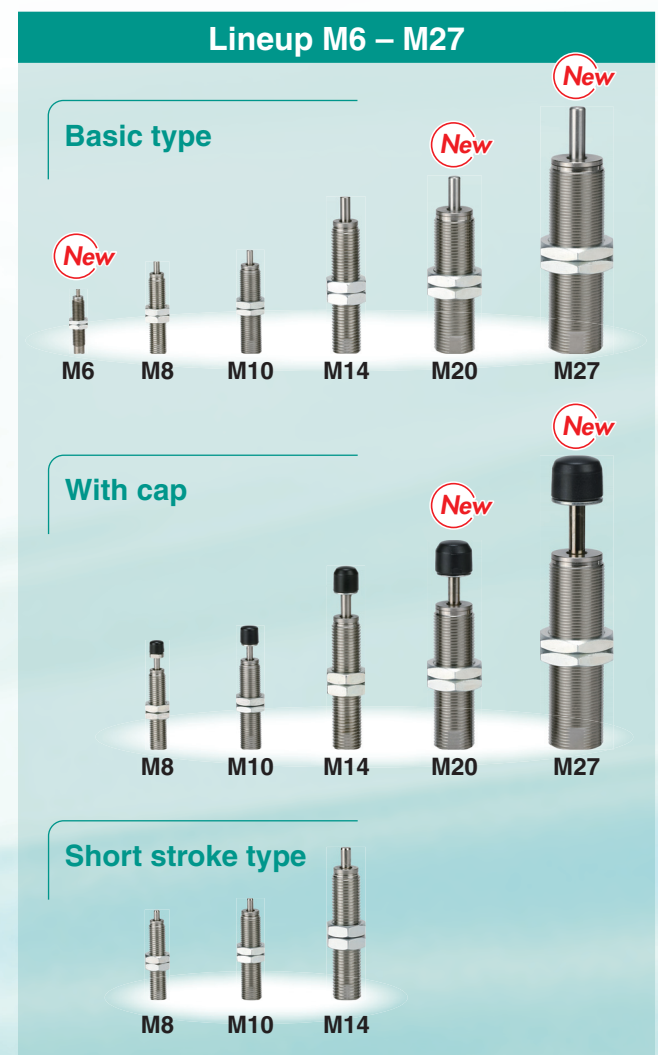

SMC



CAT.EUS20-200D-UK

Two types of absorbed energy are available as standard. Selectable in accordance with impact mass and collision speed

Soft type and short stroke type are available as standard so as to be selectable according to usage conditions (impact mass, collision speed).

Max. Absorbed Energy

★: Newly added model

Model	Collision speed [m/s]	Max. absorbed energy [J]															
		1	2	3	4	5	10	20	30	40	50	60	70	80			
Soft type 	★ RJ0604	0.05 to 1	0.5														
	RJ0806H/L	H : 0.05 to 2/L : 0.05 to 1	1														
	RJ1007H/L	H : 0.05 to 2/L : 0.05 to 1	3														
	RJ1412H/L	H : 0.05 to 2/L : 0.05 to 1	10														
	★ RJ2015H/L	H : 0.05 to 2/L : 0.05 to 1	30														
	★ RJ2725H/L	H : 0.05 to 1.5/L : 0.05 to 1	70														
Short stroke type 	RJ0805	0.05 to 1	0.5														
	RJ1006	0.05 to 1	1.5														
	RJ1410	0.05 to 1	3.7														

Pre-load mechanism working principle

Hydraulic oil in the oil pocket is supplied into the pressure chamber by elasticity of the accumulator to replenish the slight decrease of oil caused by operations.

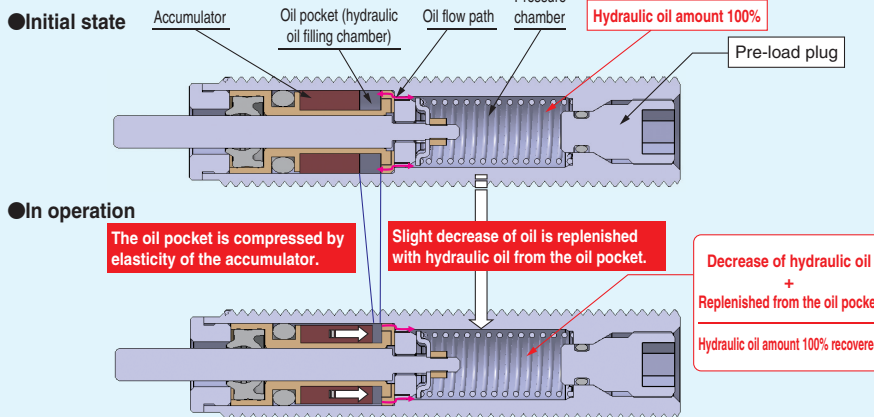

Transition of absorbed energy

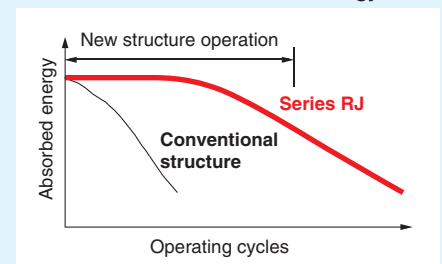

Cylinders with RJ series <Made-to-order (-XB22) applicable products> For further details, visit our website.

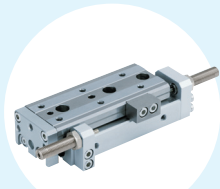

Air Slide Table
(Applicable to standard products)
Series MXQR

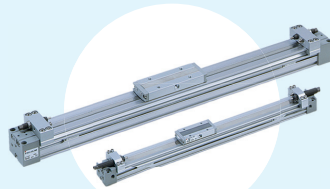

Mechanically Jointed
Rodless Cylinder
Series MY1,2,3

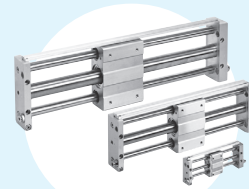

Magnetically Coupled
Rodless Cylinder
Series CY1

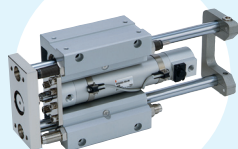

Guide Cylinder
Series MGG

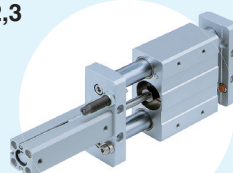

Platform Cylinder
Series CXT

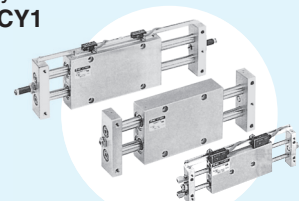







Slide Unit
Series CX2

Shock Absorbers Series Variations

● Shock Absorbers Series RJ/RB/RBL/RBQ

★: Newly added model

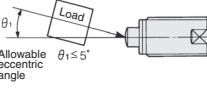
Series	Model (): With urethane cap * Series RBQ (): With bumper	Max. absorbed energy [J]	Stroke absorption [mm]	Collision speed [m/s]	O.D. thread size	Option		
Series RJ Soft type 	Basic type Short stroke type	★ RJ0604	0.5	4	0.05 to 1	M6 x 0.75	 Nut	
		RJ0806H(U)	1	6	0.05 to 2	M8 x 1.0		
		RJ0806L(U)			0.05 to 1			
		RJ1007H(U)	3	7	0.05 to 2	M10 x 1.0		
		RJ1007L(U)			0.05 to 1			
		RJ1412H(U)	10	12	0.05 to 2	M14 x 1.5		
		RJ1412L(U)			0.05 to 1			
		★ RJ2015H(U)	30	15	0.05 to 2	M20 x 1.5		
		★ RJ2015L(U)			0.05 to 1			
		★ RJ2725H(U)	70	25	0.05 to 1.5	M27 x 1.5		
		★ RJ2725L(U)			0.05 to 1			
		RB0604	0.5	4	0.3 to 1	M6 x 0.75		 Stopper nut
		RB0805(C)	0.98	5	0.05 to 5	M8 x 1.0		
RB0806(C)	2.94	6	M10 x 1.0					
RB1006(C)	3.92	6	M14 x 1.5					
RB1007(C)	5.88	7	M20 x 1.5					
RB1411(C)	14.7	11	M27 x 1.5					
RB1412(C)	19.6	12						
RB2015(C)	58.8	15						
RB2725(C)	147	25						
Series RBL Coolant resistant type 	Basic type 	RBL1006(C)	3.92	6	0.05 to 5	M10 x 1.0	 Foot bracket (Except RBQ)	
		RBL1007(C)	5.88	7		M14 x 1.5		
		RBL1411(C)	14.7	11		M20 x 1.5		
		RBL1412(C)	19.6	12		M27 x 1.5		
		RBL2015(C)	58.8	15				
		RBL2725(C)	147	25				
Series RBQ Short type 	Basic type 	RBQ1604(C)*	1.96	4	0.05 to 3	M16 x 1.5		
		RBQ2007(C)*	11.8	7		M20 x 1.5		
		RBQ2508(C)*	19.6	8		M25 x 1.5		
		RBQ3009(C)*	33.3	8.5		M30 x 1.5		
		RBQ3213(C)*	49	13		M32 x 1.5		

Shock Absorber Series RJ Model Selection 1

Model Selection Graph

* The model selection graphs ① to ⑫ are at room temperature (20 to 25°C).

■ Type of Impact

Free horizontal impact

Free horizontal impact

Impact of air cylinder actuation
(Horizontal/Upward)

Check "Model Selection Step"

① to ③ prior to use.

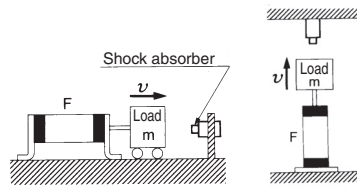

Graph ①/RJ06

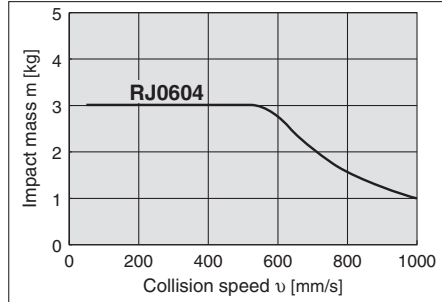

Graph ②/RJ08

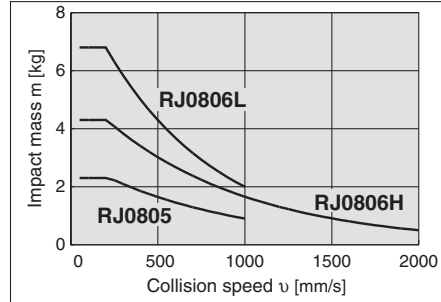

Graph ③/RJ10

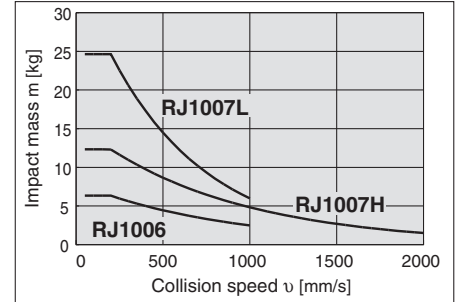

Graph ④/RJ14

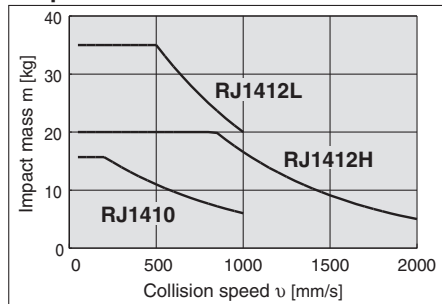

Graph ⑤/RJ20

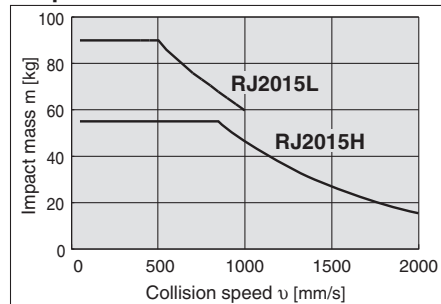

Graph ⑥/RJ27

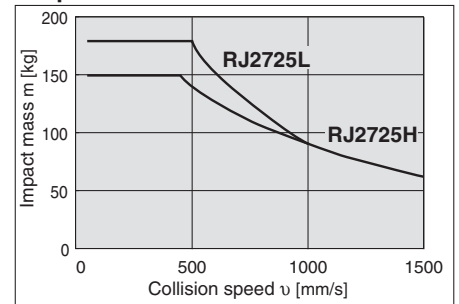

■ Type of Impact

Impact of air cylinder actuation
(Downward)

Check "Model Selection Step"

① to ③ prior to use.

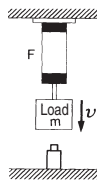

Graph ⑦/RJ06

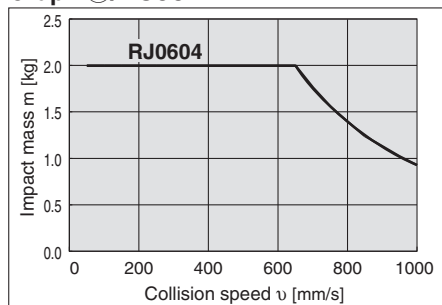

Graph ⑧/RJ08

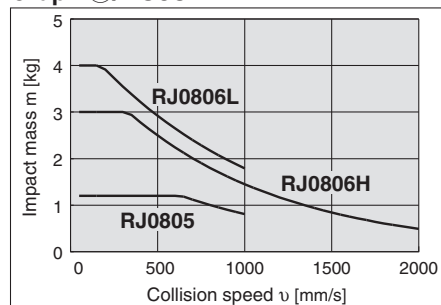

Graph ⑨/RJ10

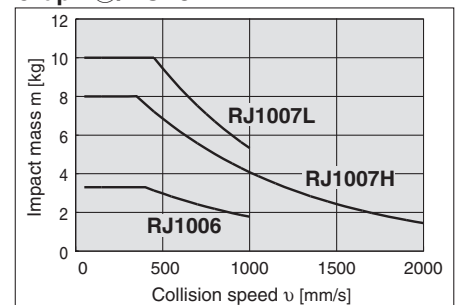

Graph ⑩/RJ14

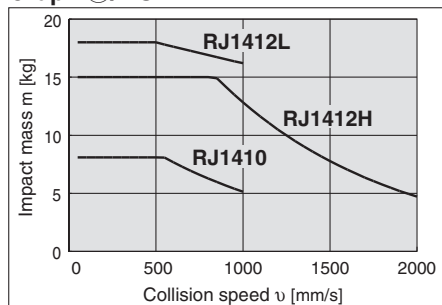

Graph ⑪/RJ20

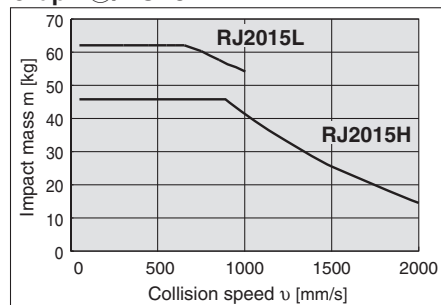

Graph ⑫/RJ27

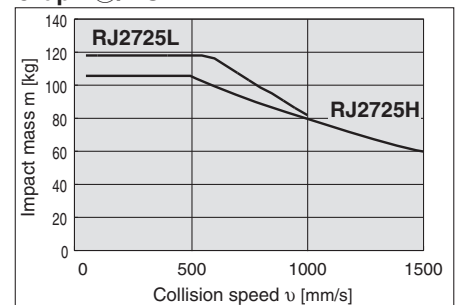

Model Selection Graph

* The model selection graphs 13 to 24 are at room temperature (20 to 25°C).

■ Type of Impact

Free fall impact

Check "Model Selection Step"

1 to 3 prior to use.

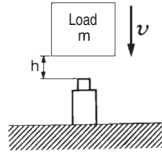

Graph 13/RJ06

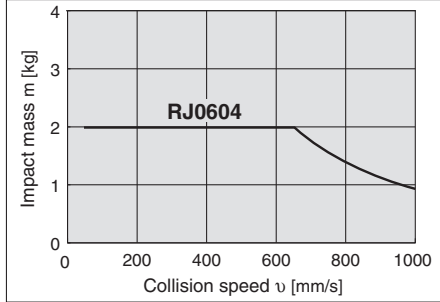

Graph 14/RJ08

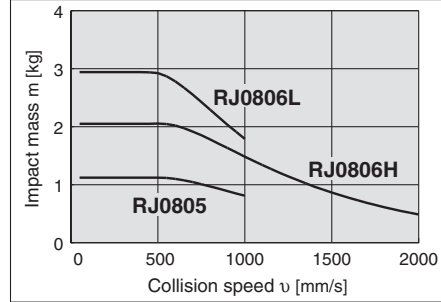

Graph 15/RJ10

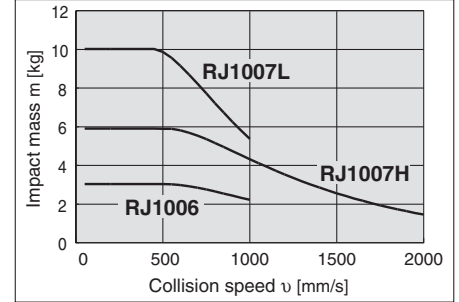

Graph 16/RJ14

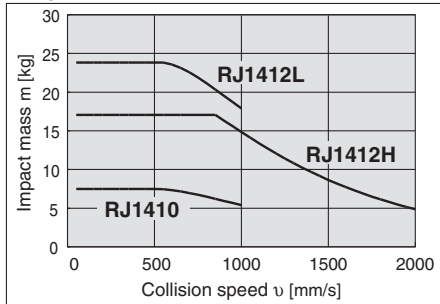

Graph 17/RJ20

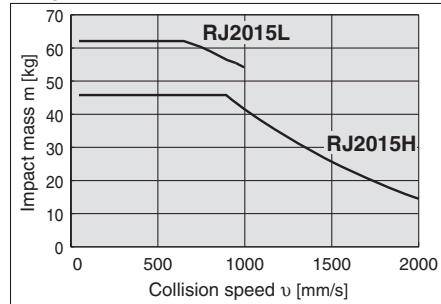

Graph 18/RJ27

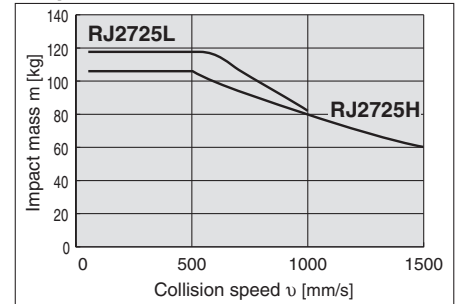

■ Type of Impact

Others (such as thrust impact or swing impact other than air cylinder actuation)

Calculate equivalent mass M_e from "Model Selection Step" 1 to 7 prior to use.

Graph 19/RJ06

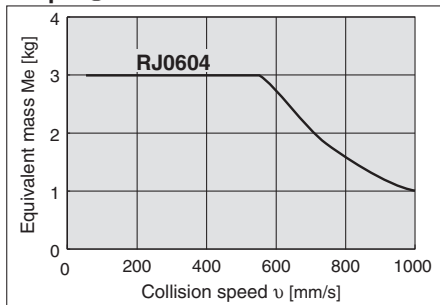

Graph 20/RJ08

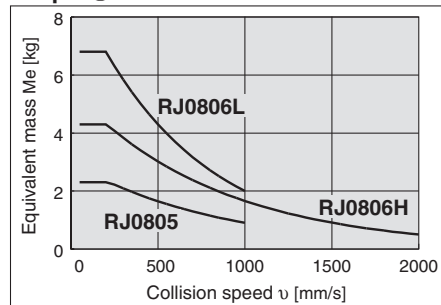

Graph 21/RJ10

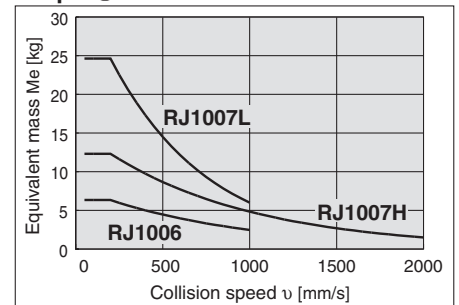

Graph 22/RJ14

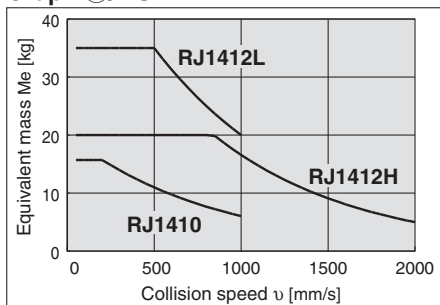

Graph 23/RJ20

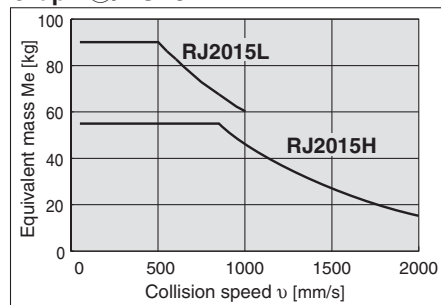

Graph 24/RJ27

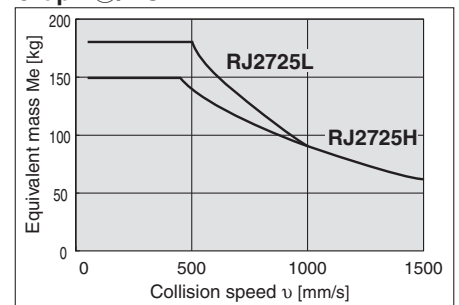

Shock Absorber Series RJ Model Selection 2

Model Selection

Model Selection Step

1 Type of impact

- Impact of thrust of load (Horizontal)
- Impact of thrust of load (Downward)
- Impact of thrust of load (Upward)
- Free horizontal impact (Impact of inertial force)
- Free fall impact
- Swing impact (With torque)

2 Operating conditions

Symbol	Operating conditions	Unit
m	Impact mass	kg
v	Collision speed	m/s
h	Dropping height	m
ω	Angular speed	rad/s
r	Distance between rotational center and impact point	m
F	Thrust	N
T	Torque	N·m
n	Operating frequency	cycle/min
t	Ambient temperature	°C
μ	Friction coefficient	—

3 Confirmation of specifications and precautions

Ensure the **collision speed, thrust, operating frequency, ambient temperature and atmosphere** fall within the specifications.
* Be aware of the minimum installation radius in the case of swing impacts.

4 Calculation of kinetic energy E₁

Calculate kinetic energy E₁ by using the formula according to the impact type.

5 Calculation of thrust energy E₂

Calculate thrust energy E₂ by selecting a model temporarily.

6 Calculation of equivalent mass Me

Calculate absorbed energy E to confirm it is not more than the maximum absorbed energy of the temporarily selected shock absorber.

$$\text{Equivalent mass } Me = \frac{2}{v^2} \cdot E$$

7 Selection of applicable model

Substitute the obtained equivalent mass Me, and the collision speed v by using "Model Selection Graph" (19) to (24) to check if the temporarily selected model is compatible with the condition of application. If satisfactory, then the temporarily selected model will be the applicable one.

Example of Selection

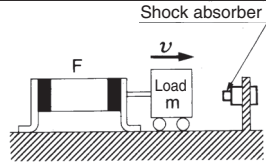
1 Type of impact		Impact of thrust of load (Horizontal) (Impact of thrust from sources other than air cylinder actuation)
		
Collision speed	^{Note 1)} v	v
Kinetic energy	E ₁	$\frac{1}{2} \cdot m \cdot v^2$
Thrust energy	E ₂	F · S
Absorbed energy	E	E ₁ + E ₂
Equivalent mass	^{Note 2)} Me	$\frac{2}{v^2} \cdot E$
2 Operating conditions		m = 5 kg v = 0.5 m/s F = 150 N n = 30 cycle/min t = 25°C
3 Confirmation of specifications and precautions		• Confirmation of specifications v ... 0.5 < 1.0 (max.), 2.0 (max.) t ... -10 (min.) < 25 < 60 (max.) F ... 150 < 422 (max.) YES
4 Calculation of kinetic energy E ₁		• Kinetic energy E ₁ Use [Formula] to calculate E ₁ by using 5.0 for m and 0.5 for v. E₁ ≈ 0.63 J
5 Calculation of thrust energy E ₂		• Thrust energy E ₂ Select the RJ1007L temporarily and obtain E ₂ by using the formula. E₂ ≈ 1.05 J
6 Calculation of equivalent mass Me		• Equivalent mass Me Use [Formula] "Absorbed energy E = E ₁ + E ₂ = 0.63 + 1.05 = 1.68 J" to calculate Me by using E and 0.5 for v. Me ≈ 13.4 kg
7 Check adequacy of the selected model RJ1007.		• Selection of applicable model According to Graph (21), the temporarily selected RJ1007L satisfies Me = 13.4 kg < 14.5 kg, resulting in an operating frequency of n = 30 < 70, without causing a problem. YES Select the RJ1007L.

Note 1) This is the momentary speed at which an object is impacting against a shock absorber. The collision speed is v = 2V when the speed (average speed V) is calculated from the air cylinder's stroke time.

Note 2) This is the theoretical mass, which is converted into the mass of the impacting material under no thrust collision conditions. Hence, E = —Me·v²

1 Type of Impact

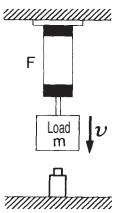
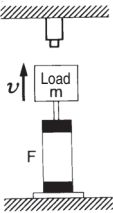
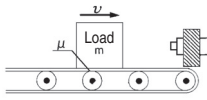
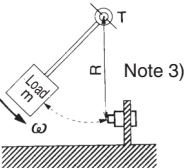
Type of impact	Impact of thrust of load (Downward) (Impact of thrust from sources other than air cylinder actuation)	Impact of thrust of load (Upward) (Impact of thrust from sources other than air cylinder actuation)	Load on conveyor (Horizontal)	Swing impact (With torque)
				
Collision speed v <small>Note 1)</small>	v	v	v	$\omega \cdot R$
Kinetic energy E_1	$\frac{1}{2} \cdot m \cdot v^2$	$\frac{1}{2} \cdot m \cdot v^2$	$\frac{1}{2} \cdot m \cdot v^2$	$\frac{1}{2} \cdot I \cdot \omega^2$
Thrust energy E_2	$F \cdot S + m \cdot g \cdot S$	$F \cdot S - m \cdot g \cdot S$	$m \cdot g \cdot \mu \cdot S$	$T \cdot \frac{S}{R}$
Absorbed energy E	$E_1 + E_2$	$E_1 + E_2$	$E_1 + E_2$	$E_1 + E_2$
Equivalent mass M_e <small>Note 2)</small>	$\frac{2}{v^2} \cdot E$	$\frac{2}{v^2} \cdot E$	$\frac{2}{v^2} \cdot E$	$\frac{2}{v^2} \cdot E$

Note 1) This is the momentary speed at which an object is impacting against a shock absorber. The collision speed is $v = \sqrt{2\bar{v}}$ when the speed (average speed \bar{v}) is calculated from the air cylinder's stroke time.

Note 2) This is the theoretical mass, which is converted into the mass of the impacting material under no thrust collision conditions. Hence, $E = \frac{1}{2} \cdot M_e \cdot v^2$

Note 3) R: The distance between rotational center and impact point. Set R at the minimum installation radius (Caution 3. Rotating angle on page 11) or higher.

<Symbol>

Symbol	Specifications	Unit
E	Absorbed energy	J
E1	Kinetic energy	J
E2	Thrust energy	J
F	Thrust	N
g	Gravitational acceleration (9.8)	m/s ²
h	Dropping height	m
I <small>Note 4)</small>	Moment of inertia around the center of gravity	kg·m ²
n	Operating frequency	cycle/min
R	Distance between rotational center and impact point	m
S	Shock absorber's stroke	m
T	Torque	N·m
t	Ambient temperature	°C
v	Collision speed	m/s
m	Impact mass	kg
M _e	Equivalent mass	kg
ω	Angular speed	rad/s
μ	Friction coefficient	—

Note 4) For the formula for moment of inertia I (kg·m²), refer to the rotary actuator's catalog.

Caution on Selection

In order for the shock absorbers to operate accurately for long hours, it is necessary to select a model that is well-suited to your operating conditions. If the impact energy is smaller than 5% of the maximum absorbed energy, select a model that is one class smaller. Use the RJ20 and 27 under the conditions mentioned below.
 RJ20: Cylinder bore size ø32 or higher or thrust 240 N or higher
 RJ27: Cylinder bore size ø40 or higher or thrust 380 N or higher

Shock Absorber Series RJ

RoHS



How to Order

RJ 0604
 RJ 0806 H U

Shock absorber/soft type

O.D. thread size/Stroke

Symbol	O.D. thread size	Stroke
0604	6 mm	4 mm
0806	8 mm	6 mm
1007	10 mm	7 mm
1412	14 mm	12 mm
2015	20 mm	15 mm
2725	27 mm	25 mm

Option

Symbol	Hexagon nut	Stopper nut
—	2 pcs.	—
J	3 pcs.	—
N	—	—
S	2 pcs.	1 pc.
SJ	3 pcs.	1 pc.
SN	—	1 pc.

Note) RJ0604: "—" or "N" only

With cap

—	Basic type
U	With urethane cap

Collision speed range

H	0.05 to 2 m/s
L	0.05 to 1 m/s

Specifications

Model	Basic type	RJ0604	RJ0806		RJ1007		RJ1412		RJ2015		RJ2725	
	With cap	—	RJ0806□U		RJ1007□U		RJ1412□U		RJ2015□U		RJ2725□U	
	Collision speed range	—	H	L	H	L	H	L	H	L	H	L
Max. absorbed energy [J] ^{Note)}		0.5	1		3		10		30		70	
O.D. thread size [mm]		6 x 0.75	8 x 1		10 x 1		14 x 1.5		20 x 1.5		27 x 1.5	
Stroke [mm]		4	6		7		12		15		25	
Collision speed [m/s]		0.05 to 1	0.05 to 2	0.05 to 1	0.05 to 2	0.05 to 1	0.05 to 2	0.05 to 1	0.05 to 2	0.05 to 1	0.05 to 1.5	0.05 to 1
Max. operating frequency [cycle/min] ^{Note)}		80	80		70		45		25		10	
Spring force [N]	Extended	1.3	2.8		5.4		6.4		14.1		14.7	
	Compressed	3.9	5.4		8.4		17.4		29.1		34.4	
Max. allowable thrust [N]		150	245		422		814		1961		2942	
Ambient temperature [°C]		-10 to 60 (No freezing)										
Weight [g]	Basic type	5.5	15		23		65		120		300	
	With cap	—	16		25		70		135		350	

Note) Max. absorbed energy and max. operating frequency values are at room temperature (20 to 25°C).

Shock Absorber Series RJ

RoHS

How to Order

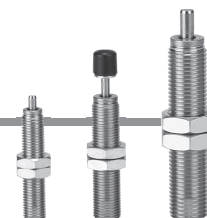

Short stroke type

RJ 0805 U

Shock absorber/soft type

O.D. thread size/Stroke

Symbol	O.D. thread size	Stroke
0805	8 mm	5 mm
1006	10 mm	6 mm
1410	14 mm	10 mm

Option

Symbol	Hexagon nut	Stopper nut
—	2 pcs.	—
J	3 pcs.	—
N	—	—
S	2 pcs.	1 pc.
SJ	3 pcs.	1 pc.
SN	—	1 pc.

With cap

—	Basic type
U	With urethane cap

Specifications

Model	Basic type	RJ0805	RJ1006	RJ1410
	With cap	RJ0805U	RJ1006U	RJ1410U
Max. absorbed energy [J] ^{Note)}		0.5	1.5	3.7
O.D. thread size [mm]		8 x 1	10 x 1	14 x 1.5
Stroke [mm]		5	6	10
Collision speed [m/s]		0.05 to 1		
Max. operating frequency [cycle/min] ^{Note)}		80	70	45
Spring force [N]	Extended	2.8	5.4	6.4
	Compressed	4.9	8.0	14.6
Max. allowable thrust [N]		245	422	814
Ambient temperature [°C]		-10 to 60 (No freezing)		
Weight [g]	Basic type	15	23	65
	With cap	16	25	70

Note) Max. absorbed energy and max. operating frequency values are at room temperature (20 to 25°C).

Replacement Parts No./Cap (Resin part only)

RBC 08 C

Cap

Applicable model

08	RJ0805U, 0806□U
10	RJ1006U, 1007□U
14	RJ1410U, 1412□U
20	RJ2015□U
27	RJ2725□U

Caps cannot be mounted on basic type. Please specify a type with cap when ordering.

Series RJ

Construction

RJ0604

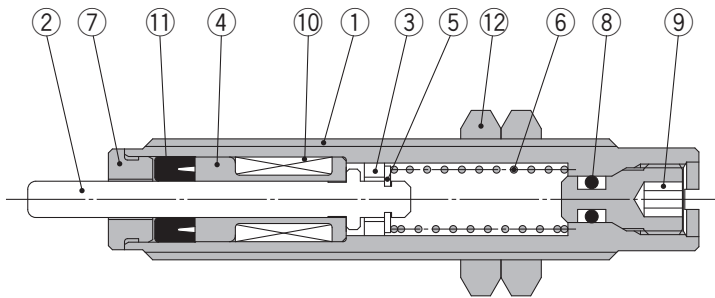

Component Parts

No.	Description	Material	Treatment
1	Tube	Special steel	Electroless nickel plating
2	Piston rod	Special steel	Electroless nickel plating
3	Piston	Stainless steel	
4	Bearing	Aluminium bearing alloy	
5	Spring guide	Tool steel	Phosphate film
6	Return spring	Steel wire	Zinc trivalent chromating
7	Stopper	Stainless steel	
8	O-ring	Synthetic rubber	
9	Plug	Special steel	Electroless nickel plating
10	Accumulator	Synthetic rubber	
11	Rod seal	Synthetic rubber	
12	Hexagon nut	Carbon steel	Zinc trivalent chromating

RJ08□□

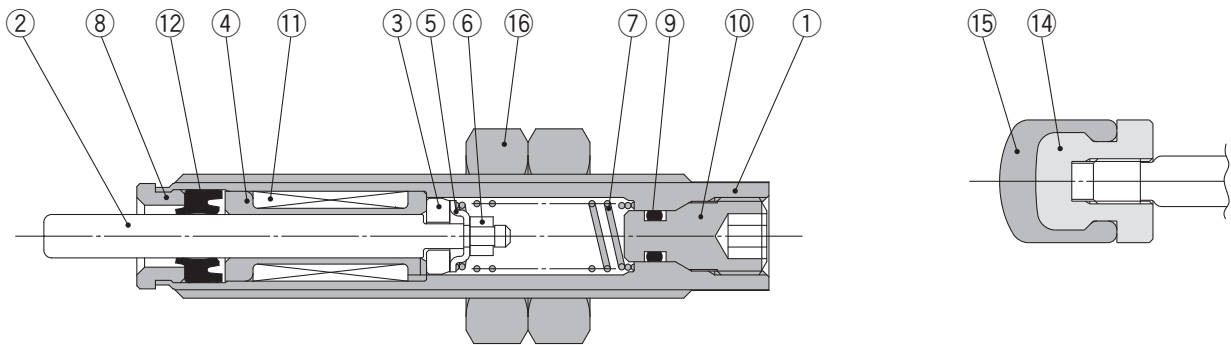

RJ10□□, 14□□, 2015, 2725

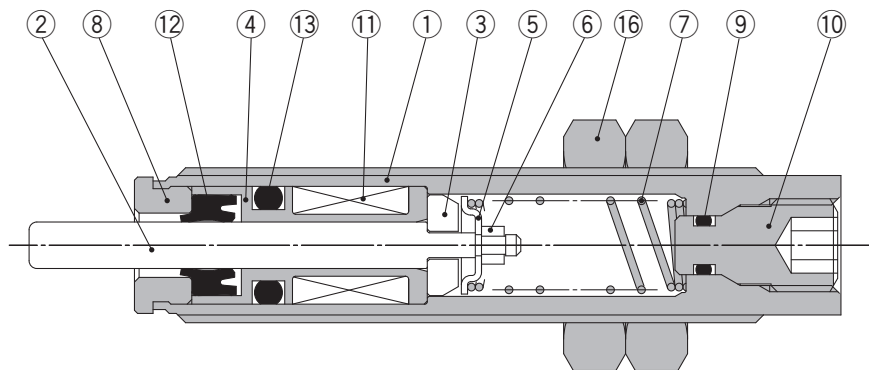

Component Parts

No.	Description	Material	Treatment
1	Tube	Special steel	Electroless nickel plating
2	Piston rod	Special steel	Electroless nickel plating
3	Piston	Stainless steel	
4	Bearing	Special bearing material	
5	Spring guide	Tool steel	Zinc trivalent chromating
6	Lock ring	Copper	
7	Return spring	Steel wire	Zinc trivalent chromating
8	Stopper	Structural steel	Electroless nickel plating
9	O-ring	Synthetic rubber	

No.	Description	Material	Treatment
10	Plug	Special steel	H: Electroless nickel plating L: Black electroless nickel plating
11	Accumulator	Synthetic rubber	
12	Rod seal	Synthetic rubber	
13	O-ring	Synthetic rubber	
14	Cap bracket	Structural steel	Zinc trivalent chromating
15	Cap	Urethane	
16	Hexagon nut	Carbon steel	Zinc trivalent chromating

Dimensions

Basic type

RJ0604

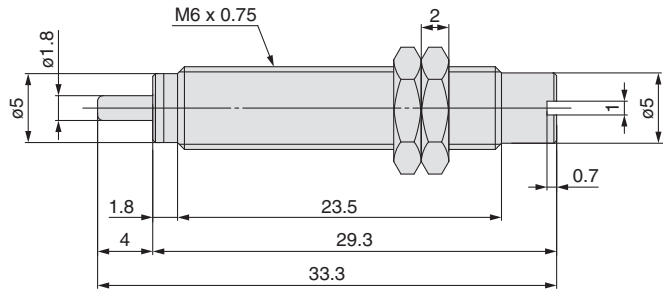
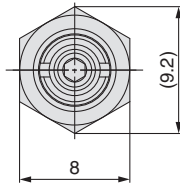

RJ08□□, 10□□, 14□□, 2015, 2725

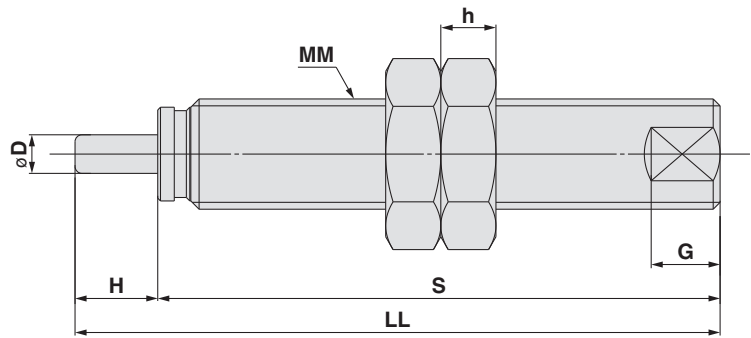
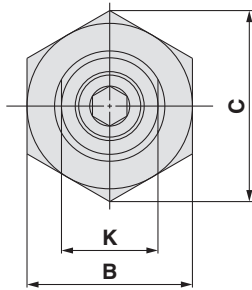

With cap

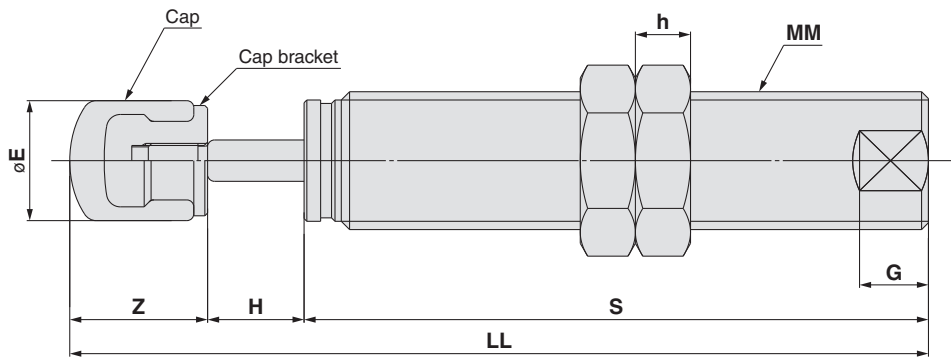

Basic type

Model		Dimensions							Hexagon nut			With cap		
		D	H	LL	MM	S	G	K	B	C	h	E	LL	Z
RJ0806□	RJ0806□U	2.8	6	46.8	M8 x 1.0	40.8	5	7	12	13.9	4	6.8	55.3	8.5
RJ1007□	RJ1007□U	3	7	52.3	M10 x 1.0	45.3	7	9	14	16.2	4	8.7	62.3	10
RJ1412□	RJ1412□U	5	12	79.1	M14 x 1.5	67.1	8	12	19	21.9	6	12	92.6	13.5
RJ2015□	RJ2015□U	6	15	88.2	M20 x 1.5	73.2	10	17	27	31.2	6	18	105.2	17
RJ2725□	RJ2725□U	8	25	124	M27 x 1.5	99	12	24	36	41.6	6	25	147	23

* The dimensions of H/L type are the same.

Short stroke type

Model		Dimensions							Hexagon nut			With cap		
		D	H	LL	MM	S	G	K	B	C	h	E	LL	Z
RJ0805	RJ0805U	2.8	5	45.8	M8 x 1.0	40.8	5	7	12	13.9	4	6.8	54.3	8.5
RJ1006	RJ1006U	3	6	51.3	M10 x 1.0	45.3	7	9	14	16.2	4	8.7	61.3	10
RJ1410	RJ1410U	5	10	77.1	M14 x 1.5	67.1	8	12	19	21.9	6	12	90.6	13.5

Series RJ

Option

Stopper nut



For basic type

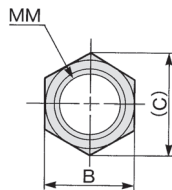
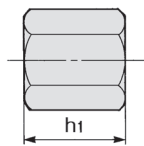

For with cap

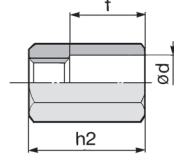

Hexagon Nut (2 pcs. are equipped as standard)

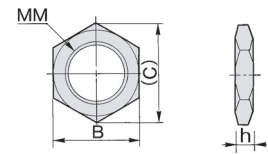

Material: Carbon steel Treatment: Zinc trivalent chromating

Part no.		Applicable absorber	Dimensions						
For basic type	For with cap		B	C	h1	h2	MM	d	f
RB08S	RBC08S	RJ08□□	12	13.9	6.5	23	M8 x 1.0	9	15
RB10S	RBC10S	RJ10□□	14	16.2	8	23	M10 x 1.0	11	15
RB14S	RBC14S	RJ14□□	19	21.9	11	31	M14 x 1.5	15	20
RB20S	RBC20S	RJ2015	27	31.2	16	40	M20 x 1.5	23	25
RB27S	RBC27S	RJ2725	36	41.6	22	51	M27 x 1.5	32	33

Material: Special steel Treatment: Zinc trivalent chromating

Part no.	Dimensions			
	MM	h	B	C
RJ06J	M6 x 0.75	2	8	9.2
RB08J	M8 x 1.0	4	12	13.9
RB10J	M10 x 1.0	4	14	16.2
RB14J	M14 x 1.5	6	19	21.9
RB20J	M20 x 1.5	6	27	31.2
RB27J	M27 x 1.5	6	36	41.6

Foot Bracket for Shock Absorber

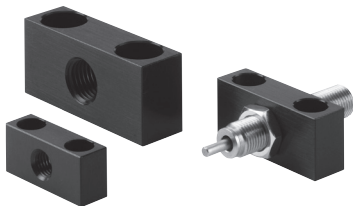

Material: Aluminum alloy
Treatment: Black hard anodized

Part no.	Applicable absorber
RB08-X331	RJ08□□
RB10-X331	RJ10□□
RB14-X331	RJ14□□
RB20-X331	RJ2015
RB27-X331	RJ2725

Replacement Parts

Cap

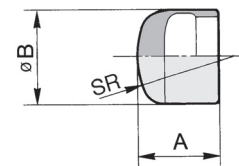

* (Replacement parts for a type with cap. Cannot be mounted on basic type.)
Material: Polyurethane

Part no.	Applicable absorber	Dimensions		
		A	B	SR
RBC08C	RJ08□□U	6.5	6.8	6
RBC10C	RJ10□□U	9	8.7	7.5
RB14C	RJ14□□U	12.5	12	10
RBC20C	RJ2015U	16	18	20
RBC27C	RJ2725U	21	25	25

Dimensions

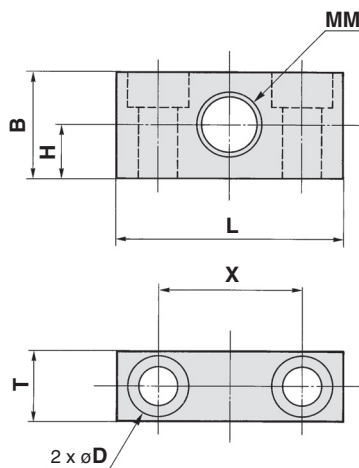

Part no.	B	D	H	L	MM	T	X	Mounting bolt
RB08-X331	15	4.5 drill, 8 counterbore depth 4.4	7.5	32	M8 x 1.0	10	20	M4
RB10-X331	19	5.5 drill, 9.5 counterbore depth 5.4	9.5	40	M10 x 1.0	12	25	M5
RB14-X331	25	9 drill, 14 counterbore depth 8.6	12.5	54	M14 x 1.5	16	34	M8
RB20-X331	38	11 drill, 17.5 counterbore depth 10.8	19	70	M20 x 1.5	22	44	M10
RB27-X331	50	13.5 drill, 20 counterbore depth 13	25	80	M27 x 1.5	34	52	M12



Series RJ

Specific Product Precautions 1

Be sure to read this before handling. Refer to the back cover for Safety Instructions, "Handling Precautions for SMC Products" (M-E03-3) for Common Precautions.

Selection

Danger

1. Absorbed energy

Select a model so that the aggregated energy of an impacting material should not exceed the maximum absorbed energy. Otherwise, it could cause changes in properties or result in damaging the shock absorber.

2. Equivalent mass

Select a model so that the equivalent mass should not exceed the allowable range. Otherwise, pulsation could occur in buffer capacity and deceleration force, thus making it difficult to absorb shock smoothly.

3. Collision speed

Use the product within the specified collision speed range. Otherwise, it could cause the changes in buffer characteristics or result in damaging the shock absorber.

Warning

1. Static load

Design the system so that any other forces than the buffer capacity or impacts should not be applied to the piston rod which is stopped at the retracted state.

Caution

1. Maximum operating frequency

Design the system in the conditions under which it is not used at the frequency exceeding the specified maximum operating frequency.

2. Stroke

The specified maximum absorbed energy cannot be exerted unless the full stroke is used.

3. Work surface of an impacting material

The contact surface of an impacting material with which the piston rod comes into contact must be highly rigid (hardness of HRC35 or more). A high surface compression load is applied to the contact surface of the impacting material with which the piston rod comes into contact.

4. Be aware of the backlash of the impacting material.

When used in a conveyor line, the object may be pushed back by the built-in spring force after energy is absorbed. For backlash, refer to the spring force in the specifications. (Pages 5 and 6)

5. Selection of size

As the number of operation proceeds, the maximum absorbed energy of shock absorbers will be decreased by the reasons such as deterioration, etc. of the internal working fluid. Taking this into consideration, selecting a size which is 20 to 40% affordable against the amount of absorbed energy is recommended.

6. Resistive force characteristics

In general, the values of resistive force (resistive force generated during the operation) generated by the operating speed will vary in oil hydraulic shock absorber. The RJ series can adapt to such this fast/slow speed and can absorb shock smoothly in a wide range of speed.

But, take note the stroke time could be long, and the motion would not be smooth, etc., depending on the operating conditions. If this would be a problem, we recommend the stroke amount should be restricted by using our optional component "stopper nut", etc.

Caution

7. Parallel usage

When using multiple shock absorbers in parallel, energy will not be divided evenly because of differences in product dimensions and devices. For this reason, select the following options.

$E = E_a / N / 0.6$

E: Energy used per shock absorber

E_a : All energies

N: The number of shock absorbers used in parallel

Operating Environment

Danger

1. Operation in an environment which requires explosion-proof

- When mounting in places where static electricity is accumulated, implement a distribution of electrical energy by grounding.
- Do not use materials for the buffer surface which might cause to spark by collision.

Warning

1. Pressure

Do not use the product in the vacuum state which is substantially different from the atmospheric pressure (above sea level) and in the atmosphere under being pressurised.

2. Using inside a clean room

Do not use the product in a clean room, as it could contaminate the clean room.

Caution

1. Temperature range

Do not use the product, exceeding the specified allowable temperature range. Seal could be softened or hardened or worn out, or leading to working fluid leak, deterioration, or buffer characteristic changes.

2. Deterioration by atmosphere

Do not use the product in the presence of salt damage, sulfurous acid gas which makes the metal corroded, or solvent which makes the seal deteriorated.

3. Deterioration by ozone

Do not use the product under the direct sunlight on the beach, or by the mercury lamp, or the ozone generator, because the rubber material will be deteriorated by ozone.

4. Cutting oil, water, blown dust

Do not use the product under the condition where the liquid such as cutting oil, water, solvent, etc. is exposed either directly or in atomised form to the piston rod, or where blown dust could be adhered around the piston rod. This could cause a malfunction.

5. Vibration

When vibrations are applied on an impacting material, implement a secure guide on the impacting material.



Series RJ

Specific Product Precautions 2

Be sure to read this before handling. Refer to the back cover for Safety Instructions, "Handling Precautions for SMC Products" (M-E03-3) for Common Precautions.

Mounting

Warning

- Before performing installation, removal, or stroke adjustment, make sure to cut the power supply to the equipment and verify that the equipment has stopped.**
- Installation of protective cover**
We recommend the protective cover should be installed for fear that workers might be getting close during the operation.
- Strength of mounting frame**
The mounting frame needs to have sufficient strength. When deciding the strength of the mounting frame, consider the load applied to the mounting frame at the upper limit of operating conditions shown in the table below, and allow a sufficient safety factor.

Model	Load on mounting frame
RJ0604	450 N
RJ0805	380 N
RJ0806	630 N
RJ1006	900 N
RJ1007	1600 N
RJ1410	1700 N
RJ1412	2000 N
RJ2015	6000 N
RJ2725	8500 N

Note) Load on mounting frame is at room temperature (20 to 25°C).

Caution

- Tightening torque and mounting thread**
When threading on the mounting frame in order to mount a shock absorber directly, refer to the prepared hole dimensions below. Observe the below tightening torque of a nut for shock absorber.
If the tightening torque exceeds the value below, the shock absorber could be damaged.
When a shock absorber is mounted on a cylinder, follow the torque values listed on each cylinder.

Model	RJ0604	RJ08□□	RJ10□□	RJ14□□	RJ2015	RJ2725
Thread dimensions [mm]	M6 x 0.75	M8 x 1.0	M10 x 1.0	M14 x 1.5	M20 x 1.5	M27 x 1.5
Thread prepared hole dia. [mm]	∅5.3 ^{+0.1} ₀	∅7.1 ^{+0.1} ₀	∅9.1 ^{+0.1} ₀	∅12.7 ^{+0.1} ₀	∅18.7 ^{+0.1} ₀	∅25.7 ^{+0.1} ₀
Nut tightening torque [N·m]	0.85	1.67	3.14	10.8	23.5	62.8

2. Deviation of impact

Mount the shock absorber so that the point of contact of an impacting material must be within the allowable eccentric angle range. If the eccentric angle is exceed 3°, an excessive load could be placed on the bearings, resulting in oil leak in a short time.

Allowable eccentric angle $\theta_1 \leq 3^\circ$

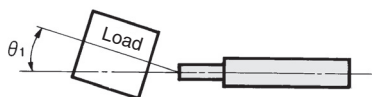

For with cap $\theta_1 \leq 1^\circ$

Caution

3. Rotating angle

If swing impacts are involved, the installation must be designed so that the direction in which a load is applied should be perpendicular to the shock absorber's axial center.
The rotating eccentric angle to the stroke end must be $\theta_2 \leq 3^\circ$.

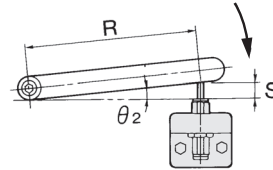

Allowable rotating eccentric angle $\theta_2 \leq 3^\circ$

Installation Requirement for Swing Impacts [mm]

Model	S (Stroke)	θ_2 (Allowable rotating angle)	R (Min. installation radius)	
			Basic type	With cap
RJ0604	4	3°	76	—
RJ0805	5		96	258
RJ0806	6		115	277
RJ1006	6		115	306
RJ1007	7		134	325
RJ1410	10		191	449
RJ1412	12		229	487
RJ2015	15		287	611
RJ2725	25		478	916

4. Do not scratch the sliding portion of the piston rod or the outside threads of the outer tube.

Failure to observe this precaution could scratch or gouge the sliding portion of the piston rod, or damage the seals, resulting in oil leak or malfunction. Furthermore, damage to outside threaded portion of the outer tube could prevent the shock absorber from being mounted onto the frame, or result in a malfunction by internal component parts deformation.

5. Never turn the screw on the bottom of the body.

This is not an adjusting screw. Otherwise, oil leak could occur.

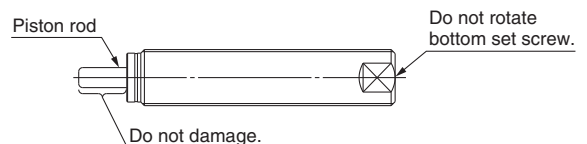



Series RJ

Specific Product Precautions 3

Be sure to read this before handling. Refer to the back cover for Safety Instructions, "Handling Precautions for SMC Products" (M-E03-3) for Common Precautions.

Mounting

⚠ Warning

6. Adjust the stopping time by using a stopper nut.

Control the stopping time of the impacting material by turning the stopper nut in or out (thus changing length "a"). After establishing the stopper nut position, use a hexagon nut to secure the stopper nut in place.

Capacity of shock absorbers deteriorate in accordance with usage. When crashing sounds or vibrations are generated during the operation, adjust the stopper nut and make the effective stroke (a) longer, or give the stroke enough leeway beforehand.

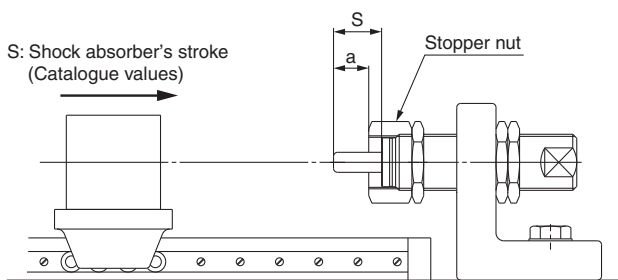

Maintenance

⚠ Caution

1. Confirm that the mounting nut is not loosen.

The shock absorber could be damaged if used in a loosen state.

2. Pay attention to any abnormal impact sounds or vibrations.

If impact sounds or vibrations become abnormally high, the shock absorber may reach the end of its service life. Replace the shock absorber. If using continuously in such a state, equipment could be damaged.

3. Confirm that there is no oil leak on the outer surface.

When a large amount of oil is leaking, replace the product, because it is believed to be happening something wrong with it. If using continuously in such a state, equipment could be damaged.

4. Check for cracks and wear in caps.

For shock absorbers with caps, the caps will wear out first. Replace caps early to prevent damage to colliding objects.

Storage

⚠ Caution

1. Position of the piston rod during storage

If the product is stored for an extended period (30 days or more) with the piston rod pushed, the absorption capacity could decrease. Avoid this kind of storage condition.

Shock Absorber Replacement Period



⚠ Caution

1. The cylinder, equipment and/or workpieces might be destroyed if the table collides the end of the stroke without being buffered properly by the shock absorber.

Check the conditions periodically and adjust or replace the shock absorber, if necessary. About 3 million cycles are possible within the catalogue usage range (model selection graph range), so check the condition after 1.5 million cycles for the RJ06 (room temperature: 20 to 25°C). Maximum operating cycles of 10 million is confirmed under our in-house conditions (room temperature: 20 to 25°C, impact load factor 50%, linear cylinder collision), so by making a size selection with much leeway, long operational life will be possible.

Safety Instructions

These safety instructions are intended to prevent hazardous situations and/or equipment damage. These instructions indicate the level of potential hazard with the labels of “**Caution**,” “**Warning**” or “**Danger**.” They are all important notes for safety and must be followed in addition to International Standards (ISO/IEC)*1), and other safety regulations.

-  **Caution:** **Caution** indicates a hazard with a low level of risk which, if not avoided, could result in minor or moderate injury.
-  **Warning:** **Warning** indicates a hazard with a medium level of risk which, if not avoided, could result in death or serious injury.
-  **Danger:** **Danger** indicates a hazard with a high level of risk which, if not avoided, will result in death or serious injury.

- *1) ISO 4414: Pneumatic fluid power – General rules relating to systems.
 ISO 4413: Hydraulic fluid power – General rules relating to systems.
 IEC 60204-1: Safety of machinery – Electrical equipment of machines.
 (Part 1: General requirements)
 ISO 10218-1: Manipulating industrial robots - Safety.
 etc.

Warning

- The compatibility of the product is the responsibility of the person who designs the equipment or decides its specifications.**
 Since the product specified here is used under various operating conditions, its compatibility with specific equipment must be decided by the person who designs the equipment or decides its specifications based on necessary analysis and test results. The expected performance and safety assurance of the equipment will be the responsibility of the person who has determined its compatibility with the product. This person should also continuously review all specifications of the product referring to its latest catalogue information, with a view to giving due consideration to any possibility of equipment failure when configuring the equipment.
- Only personnel with appropriate training should operate machinery and equipment.**
 The product specified here may become unsafe if handled incorrectly. The assembly, operation and maintenance of machines or equipment including our products must be performed by an operator who is appropriately trained and experienced.
- Do not service or attempt to remove product and machinery/equipment until safety is confirmed.**
 - The inspection and maintenance of machinery/equipment should only be performed after measures to prevent falling or runaway of the driven objects have been confirmed.
 - When the product is to be removed, confirm that the safety measures as mentioned above are implemented and the power from any appropriate source is cut, and read and understand the specific product precautions of all relevant products carefully.
 - Before machinery/equipment is restarted, take measures to prevent unexpected operation and malfunction.
- Contact SMC beforehand and take special consideration of safety measures if the product is to be used in any of the following conditions.**
 - Conditions and environments outside of the given specifications, or use outdoors or in a place exposed to direct sunlight.
 - Installation on equipment in conjunction with atomic energy, railways, air navigation, space, shipping, vehicles, military, medical treatment, combustion and recreation, or equipment in contact with food and beverages, emergency stop circuits, clutch and brake circuits in press applications, safety equipment or other applications unsuitable for the standard specifications described in the product catalogue.
 - An application which could have negative effects on people, property, or animals requiring special safety analysis.
 - Use in an interlock circuit, which requires the provision of double interlock for possible failure by using a mechanical protective function, and periodical checks to confirm proper operation.

Caution

- The product is provided for use in manufacturing industries.**
 The product herein described is basically provided for peaceful use in manufacturing industries.
 If considering using the product in other industries, consult SMC beforehand and exchange specifications or a contract if necessary.
 If anything is unclear, contact your nearest sales branch.

Limited warranty and Disclaimer/ Compliance Requirements

The product used is subject to the following “Limited warranty and Disclaimer” and “Compliance Requirements”.

Read and accept them before using the product.

Limited warranty and Disclaimer

- The warranty period of the product is 1 year in service or 1.5 years after the product is delivered.*2)
 Also, the product may have specified durability, running distance or replacement parts. Please consult your nearest sales branch.
- For any failure or damage reported within the warranty period which is clearly our responsibility, a replacement product or necessary parts will be provided.
 This limited warranty applies only to our product independently, and not to any other damage incurred due to the failure of the product.
- Prior to using SMC products, please read and understand the warranty terms and disclaimers noted in the specified catalogue for the particular products.

*2) Vacuum pads are excluded from this 1 year warranty.

A vacuum pad is a consumable part, so it is warranted for a year after it is delivered. Also, even within the warranty period, the wear of a product due to the use of the vacuum pad or failure due to the deterioration of rubber material are not covered by the limited warranty.

Compliance Requirements

- The use of SMC products with production equipment for the manufacture of weapons of mass destruction (WMD) or any other weapon is strictly prohibited.
- The exports of SMC products or technology from one country to another are governed by the relevant security laws and regulations of the countries involved in the transaction. Prior to the shipment of a SMC product to another country, assure that all local rules governing that export are known and followed.

Safety Instructions

Be sure to read “Handling Precautions for SMC Products” (M-E03-3) before using.

SMC Corporation (Europe)

Austria	☎ +43 (0)2262622800	www.smc.at	office@smc.at
Belgium	☎ +32 (0)33551464	www.smc-pneumatics.be	info@smc-pneumatics.be
Bulgaria	☎ +359 (0)2807670	www.smc.bg	office@smc.bg
Croatia	☎ +385 (0)13707288	www.smc.hr	office@smc.hr
Czech Republic	☎ +420 541424611	www.smc.cz	office@smc.cz
Denmark	☎ +45 70252900	www.smc.dk.com	smc@smcdk.com
Estonia	☎ +372 6510370	www.smc-pneumatics.ee	smc@smc-pneumatics.ee
Finland	☎ +358 207513513	www.smc.fi	smcffi@smc.fi
France	☎ +33 (0)164761000	www.smc-france.fr	promotion@smc-france.fr
Germany	☎ +49 (0)61034020	www.smc.de	info@smc.de
Greece	☎ +30 210 2717265	www.smc-hellas.gr	sales@smchellas.gr
Hungary	☎ +36 23511390	www.smc.hu	office@smc.hu
Ireland	☎ +353 (0)14039000	www.smc-pneumatics.ie	sales@smc-pneumatics.ie
Italy	☎ +39 0292711	www.smc-italia.it	mailbox@smc-italia.it
Latvia	☎ +371 67817700	www.smc.lv	info@smclv.lv

Lithuania	☎ +370 5 2308118	www.smclt.lt	info@smclt.lt
Netherlands	☎ +31 (0)205318888	www.smc-pneumatics.nl	info@smc-pneumatics.nl
Norway	☎ +47 67129020	www.smc-norge.no	post@smc-norge.no
Poland	☎ +48 (0)222119616	www.smc.pl	office@smc.pl
Portugal	☎ +351 226166570	www.smc.eu	postpt@smc.smces.es
Romania	☎ +40 213205111	www.smcromania.ro	smcromania@smcromania.ro
Russia	☎ +7 8127185445	www.smc-pneumatik.ru	info@smc-pneumatik.ru
Slovakia	☎ +421 (0)413213212	www.smc.sk	office@smc.sk
Slovenia	☎ +386 (0)73885412	www.smc.si	office@smc.si
Spain	☎ +34 902184100	www.smc.eu	post@smc.smces.es
Sweden	☎ +46 (0)86031200	www.smc.nu	post@smc.nu
Switzerland	☎ +41 (0)523963131	www.smc.ch	info@smc.ch
Turkey	☎ +90 212 489 0 440	www.smc-pneumatik.com.tr	info@smc-pneumatik.com.tr
UK	☎ +44 (0)845 121 5122	www.smc-pneumatics.co.uk	sales@smc-pneumatics.co.uk