



**PIC32MX5XX/6XX/7XX**  
**Family Data Sheet**

High-Performance, USB, CAN and Ethernet  
32-bit Flash Microcontrollers

---

**Note the following details of the code protection feature on Microchip devices:**

- Microchip products meet the specification contained in their particular Microchip Data Sheet.
- Microchip believes that its family of products is one of the most secure families of its kind on the market today, when used in the intended manner and under normal conditions.
- There are dishonest and possibly illegal methods used to breach the code protection feature. All of these methods, to our knowledge, require using the Microchip products in a manner outside the operating specifications contained in Microchip's Data Sheets. Most likely, the person doing so is engaged in theft of intellectual property.
- Microchip is willing to work with the customer who is concerned about the integrity of their code.
- Neither Microchip nor any other semiconductor manufacturer can guarantee the security of their code. Code protection does not mean that we are guaranteeing the product as "unbreakable."

Code protection is constantly evolving. We at Microchip are committed to continuously improving the code protection features of our products. Attempts to break Microchip's code protection feature may be a violation of the Digital Millennium Copyright Act. If such acts allow unauthorized access to your software or other copyrighted work, you may have a right to sue for relief under that Act.

---

Information contained in this publication regarding device applications and the like is provided only for your convenience and may be superseded by updates. It is your responsibility to ensure that your application meets with your specifications. MICROCHIP MAKES NO REPRESENTATIONS OR WARRANTIES OF ANY KIND WHETHER EXPRESS OR IMPLIED, WRITTEN OR ORAL, STATUTORY OR OTHERWISE, RELATED TO THE INFORMATION, INCLUDING BUT NOT LIMITED TO ITS CONDITION, QUALITY, PERFORMANCE, MERCHANTABILITY OR FITNESS FOR PURPOSE. Microchip disclaims all liability arising from this information and its use. Use of Microchip devices in life support and/or safety applications is entirely at the buyer's risk, and the buyer agrees to defend, indemnify and hold harmless Microchip from any and all damages, claims, suits, or expenses resulting from such use. No licenses are conveyed, implicitly or otherwise, under any Microchip intellectual property rights.

**Trademarks**

The Microchip name and logo, the Microchip logo, dsPIC, KEELOQ, KEELOQ logo, MPLAB, PIC, PICmicro, PICSTART, PIC<sup>32</sup> logo, rPIC and UNI/O are registered trademarks of Microchip Technology Incorporated in the U.S.A. and other countries.


FilterLab, Hampshire, HI-TECH C, Linear Active Thermistor, MXDEV, MXLAB, SEEVAL and The Embedded Control Solutions Company are registered trademarks of Microchip Technology Incorporated in the U.S.A.

Analog-for-the-Digital Age, Application Maestro, CodeGuard, dsPICDEM, dsPICDEM.net, dsPICworks, dsSPEAK, ECAN, ECONOMONITOR, FanSense, HI-TIDE, In-Circuit Serial Programming, ICSP, Mindi, MiWi, MPASM, MPLAB Certified logo, MPLIB, MPLINK, mTouch, Octopus, Omniscient Code Generation, PICC, PICC-18, PICDEM, PICDEM.net, PICKit, PICtail, REAL ICE, rLAB, Select Mode, Total Endurance, TSHARC, UniWinDriver, WiperLock and ZENA are trademarks of Microchip Technology Incorporated in the U.S.A. and other countries.

SQTP is a service mark of Microchip Technology Incorporated in the U.S.A.

All other trademarks mentioned herein are property of their respective companies.

© 2010, Microchip Technology Incorporated, Printed in the U.S.A., All Rights Reserved.

 Printed on recycled paper.

ISBN: 978-1-60932-274-8

*Microchip received ISO/TS-16949:2002 certification for its worldwide headquarters, design and wafer fabrication facilities in Chandler and Tempe, Arizona; Gresham, Oregon and design centers in California and India. The Company's quality system processes and procedures are for its PIC<sup>®</sup> MCUs and dsPIC<sup>®</sup> DSCs, KEELOQ<sup>®</sup> code hopping devices, Serial EEPROMs, microperipherals, nonvolatile memory and analog products. In addition, Microchip's quality system for the design and manufacture of development systems is ISO 9001:2000 certified.*

**QUALITY MANAGEMENT SYSTEM  
CERTIFIED BY DNV  
== ISO/TS 16949:2002 ==**



# PIC32MX5XX/6XX/7XX

---

---

## High-Performance, USB, CAN and Ethernet 32-bit Flash Microcontrollers

---

---

### High-Performance 32-bit RISC CPU:

- MIPS32® M4K® 32-bit core with 5-stage pipeline
- 80 MHz maximum frequency
- 1.56 DMIPS/MHz (Dhrystone 2.1) performance at zero Wait state Flash access
- Single-cycle multiply and high-performance divide unit
- MIPS16e™ mode for up to 40% smaller code size
- Two sets of 32 core register files (32-bit) to reduce interrupt latency
- Prefetch Cache module to speed execution from Flash

### Microcontroller Features:

- Operating voltage range of 2.3V to 3.6V
- 64K to 512K Flash memory (plus an additional 12 KB of Boot Flash)
- 16K to 128K SRAM memory
- Pin-compatible with most PIC24/dsPIC® DSC devices
- Multiple power management modes
- Multiple interrupt vectors with individually programmable priority
- Fail-Safe Clock Monitor mode
- Configurable Watchdog Timer with on-chip Low-Power RC oscillator for reliable operation

### Peripheral Features:

- Atomic SET, CLEAR and INVERT operation on select peripheral registers
- Up to 8-channels of hardware DMA with automatic data size detection
- USB 2.0-compliant full-speed device and On-The-Go (OTG) controller:
  - Dedicated DMA channels
- 10/100 Mbps Ethernet MAC with MII and RMII interface:
  - Dedicated DMA channels
- CAN module:
  - 2.0B Active with DeviceNet™ addressing support
  - Dedicated DMA channels
- 3 MHz to 25 MHz crystal oscillator

### Peripheral Features (Continued):

- Internal 8 MHz and 32 kHz oscillators
- Six UART modules with:
  - RS-232, RS-485 and LIN 1.2 support
  - IrDA® with on-chip hardware encoder and decoder
- Up to four SPI modules
- Up to five I<sup>2</sup>C™ modules
- Separate PLLs for CPU and USB clocks
- Parallel Master and Slave Port (PMP/PSP) with 8-bit and 16-bit data, and up to 16 address lines
- Hardware Real-Time Clock and Calendar (RTCC)
- Five 16-bit Timers/Counters (two 16-bit pairs combine to create two 32-bit timers)
- Five Capture inputs
- Five Compare/PWM outputs
- Five external interrupt pins
- High-speed I/O pins capable of toggling at up to 80 MHz
- High-current sink/source (18 mA/18 mA) on all I/O pins
- Configurable open-drain output on digital I/O pins

### Debug Features:

- Two programming and debugging Interfaces:
  - 2-wire interface with unintrusive access and real-time data exchange with application
  - 4-wire MIPS® standard enhanced Joint Test Action Group (JTAG) interface
- Unintrusive hardware-based instruction trace
- IEEE Standard 1149.2 compatible (JTAG) boundary scan

### Analog Features:

- Up to 16-channel, 10-bit Analog-to-Digital Converter:
  - 1 Msps conversion rate
  - Conversion available during Sleep and Idle
- Two Analog Comparators
- 5V tolerant input pins (digital pins only)

# PIC32MX5XX/6XX/7XX

**TABLE 1: PIC32MX USB AND CAN – FEATURES**

USB and CAN																
Device	Pins	Program Memory (KB)	Data Memory (KB)	USB	CAN	Timers/Capture/Compare	DMA Channels (Programmable/Dedicated)	UART <sup>(2,3)</sup>	SPI <sup>(3)</sup>	I <sup>2</sup> C™ <sup>(3)</sup>	10-bit 1 Msps ADC (Channels)	Comparators	PMP/PSP	JTAG	Trace	Packages <sup>(4)</sup>
PIC32MX575F256H	64	256 + 12 <sup>(1)</sup>	64	1	1	5/5/5	8/4	6	3	4	16	2	Yes	Yes	No	PT, MR
PIC32MX575F512H	64	512 + 12 <sup>(1)</sup>	64	1	1	5/5/5	8/4	6	3	4	16	2	Yes	Yes	No	PT, MR
PIC32MX575F256L	100	256 + 12 <sup>(1)</sup>	64	1	1	5/5/5	8/4	6	4	5	16	2	Yes	Yes	Yes	PT, PF, BG
PIC32MX575F512L	100	512 + 12 <sup>(1)</sup>	64	1	1	5/5/5	8/4	6	4	5	16	2	Yes	Yes	Yes	PT, PF, BG

**Legend:** PF, PT = TQFP      MR = QFN      BG = XBGA

**Note 1:** This device features 12 KB boot Flash memory.

**2:** CTS and RTS pins may not be available for all UART modules. Refer to the “Pin Diagrams” section for more information.

**3:** Some pins between the UART, SPI and I<sup>2</sup>C modules may be shared. Refer to the “Pin Diagrams” section for more information.

**4:** Refer to Section 32.0 “Packaging Information” for more information.

# PIC32MX5XX/6XX/7XX

**TABLE 2: PIC32MX USB AND ETHERNET – FEATURES**

USB and Ethernet																
Device	Pins	Program Memory (KB)	Data Memory (KB)	USB	Ethernet	Timers/Capture/Compare	DMA Channels (Programmable/Dedicated)	UART <sup>(2,3)</sup>	SPI <sup>(3)</sup>	I <sup>2</sup> C™ <sup>(3)</sup>	10-bit 1 Msps ADC (Channels)	Comparators	PMP/PSP	JTAG	Trace	Packages <sup>(4)</sup>
PIC32MX675F256H	64	256 + 12 <sup>(1)</sup>	64	1	1	5/5/5	8/4	6	3	4	16	2	Yes	Yes	No	PT, MR
PIC32MX675F512H	64	512 + 12 <sup>(1)</sup>	64	1	1	5/5/5	8/4	6	3	4	16	2	Yes	Yes	No	PT, MR
PIC32MX695F512H	64	512 + 12 <sup>(1)</sup>	128	1	1	5/5/5	8/4	6	3	4	16	2	Yes	Yes	No	PT, MR
PIC32MX675F512L	100	512 + 12 <sup>(1)</sup>	64	1	1	5/5/5	8/4	6	4	5	16	2	Yes	Yes	Yes	PT, PF, BG
PIC32MX675F256L	100	256 + 12 <sup>(1)</sup>	64	1	1	5/5/5	8/4	6	4	5	16	2	Yes	Yes	Yes	PT, PF, BG
PIC32MX695F512L	100	512 + 12 <sup>(1)</sup>	128	1	1	5/5/5	8/4	6	4	5	16	2	Yes	Yes	Yes	PT, PF, BG

**Legend:** PF, PT = TQFP MR = QFN BG = XBGA

**Note 1:** This device features 12 KB boot Flash memory.

**2:** CTS and RTS pins may not be available for all UART modules. Refer to the “Pin Diagrams” section for more information.

**3:** Some pins between the UART, SPI and I<sup>2</sup>C modules may be shared. Refer to the “Pin Diagrams” section for more information.

**4:** Refer to **Section 32.0 “Packaging Information”** for more information.

# PIC32MX5XX/6XX/7XX

**TABLE 3: PIC32MX USB, ETHERNET AND CAN – FEATURES**

USB, Ethernet and CAN																	
Device	Pins	Program Memory (KB)	Data Memory (KB)	USB	Ethernet	CAN	Timers/Capture/Compare	DMA Channels (Programmable/Dedicated)	UART <sup>(2,3)</sup>	SPI <sup>(3)</sup>	I <sup>2</sup> C <sup>TM(3)</sup>	10-bit 1 Msps ADC (Channels)	Comparators	PMP/PSP	JTAG	Trace	Packages <sup>(4)</sup>
PIC32MX775F256H	64	256 + 12 <sup>(1)</sup>	64	1	1	2	5/5/5	8/8	6	3	4	16	2	Yes	Yes	No	PT, MR
PIC32MX775F512H	64	512 + 12 <sup>(1)</sup>	64	1	1	2	5/5/5	8/8	6	3	4	16	2	Yes	Yes	No	PT, MR
PIC32MX795F512H	64	512 + 12 <sup>(1)</sup>	128	1	1	2	5/5/5	8/8	6	3	4	16	2	Yes	Yes	No	PT, MR
PIC32MX775F256L	100	256 + 12 <sup>(1)</sup>	64	1	1	2	5/5/5	8/8	6	4	5	16	2	Yes	Yes	Yes	PT, PF, BG
PIC32MX775F512L	100	512 + 12 <sup>(1)</sup>	64	1	1	2	5/5/5	8/8	6	4	5	16	2	Yes	Yes	Yes	PT, PF, BG
PIC32MX795F512L	100	512 + 12 <sup>(1)</sup>	128	1	1	2	5/5/5	8/8	6	4	5	16	2	Yes	Yes	Yes	PT, PF, BG

**Legend:** PF, PT = TQFP      MR = QFN      BG = XBGA

**Note 1:** This device features 12 KB boot Flash memory.

**2:** CTS and RTS pins may not be available for all UART modules. Refer to the “Pin Diagrams” section for more information.

**3:** Some pins between the UART, SPI and I<sup>2</sup>C modules may be shared. Refer to the “Pin Diagrams” section for more information.

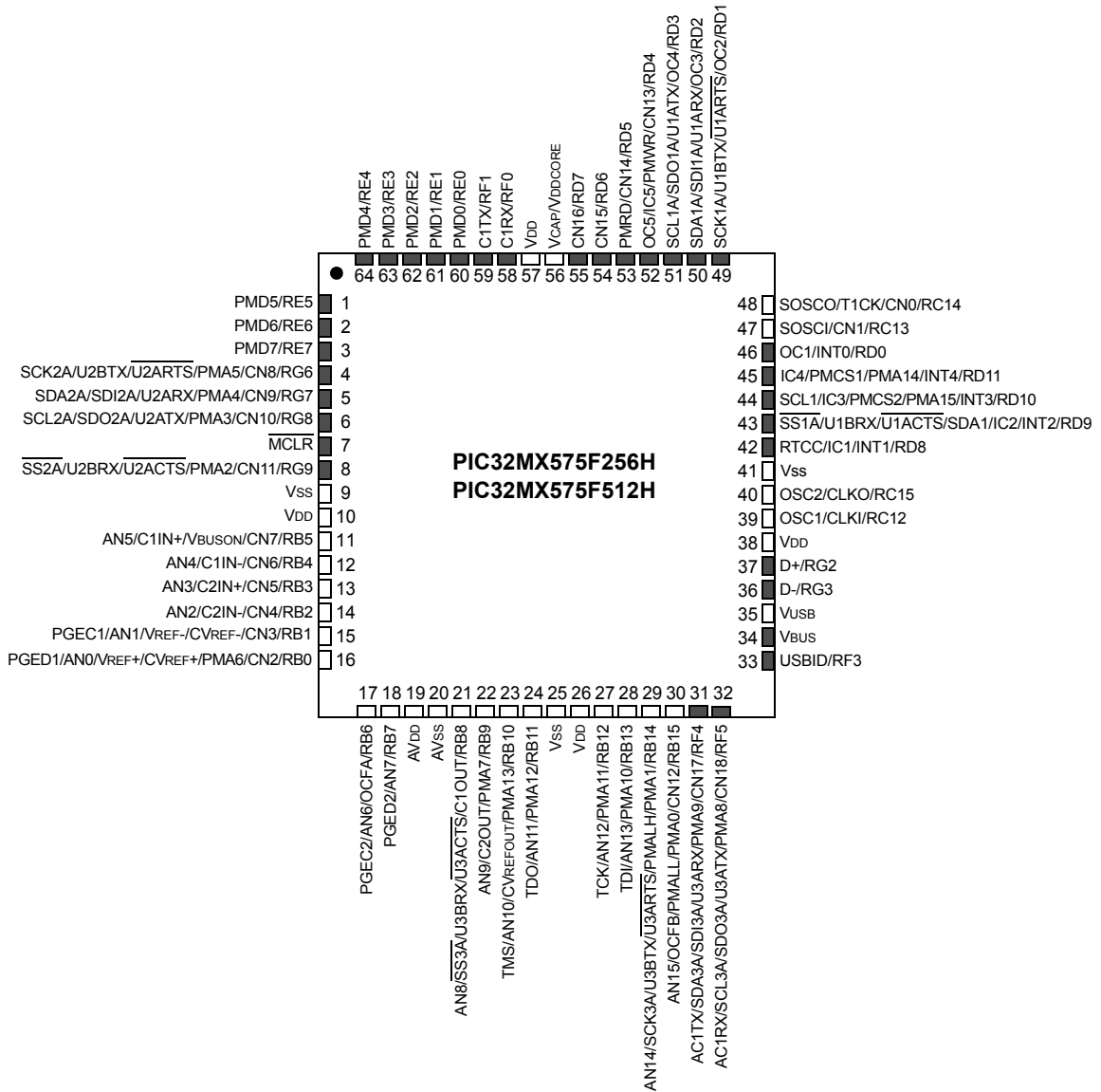
**4:** Refer to **Section 32.0 “Packaging Information”** for more information.

# PIC32MX5XX/6XX/7XX

## Pin Diagrams

### 64-Pin QFN

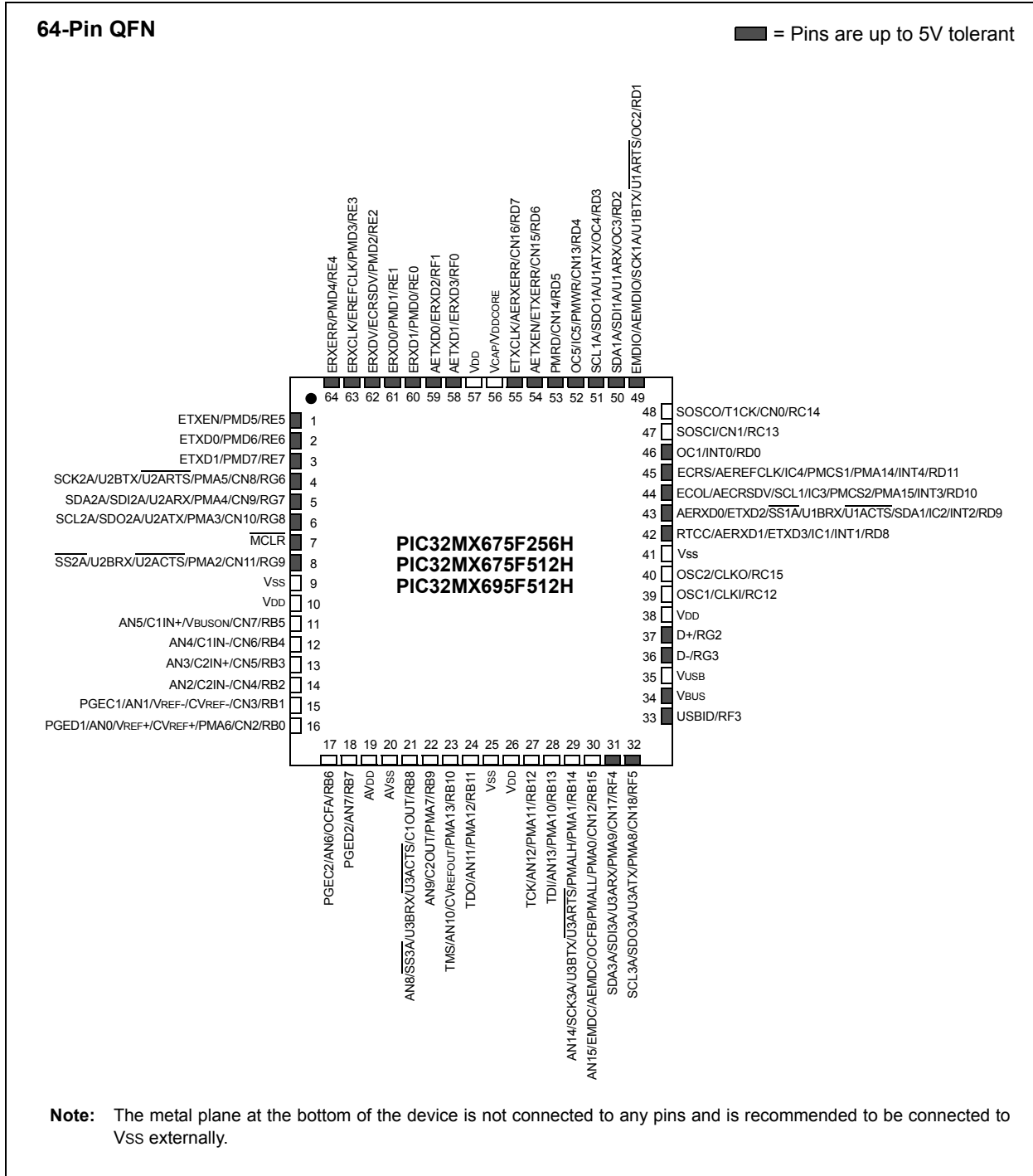
■ = Pins are up to 5V tolerant



**Note:** The metal plane at the bottom of the device is not connected to any pins and is recommended to be connected to Vss externally.

# PIC32MX5XX/6XX/7XX

## Pin Diagrams (Continued)

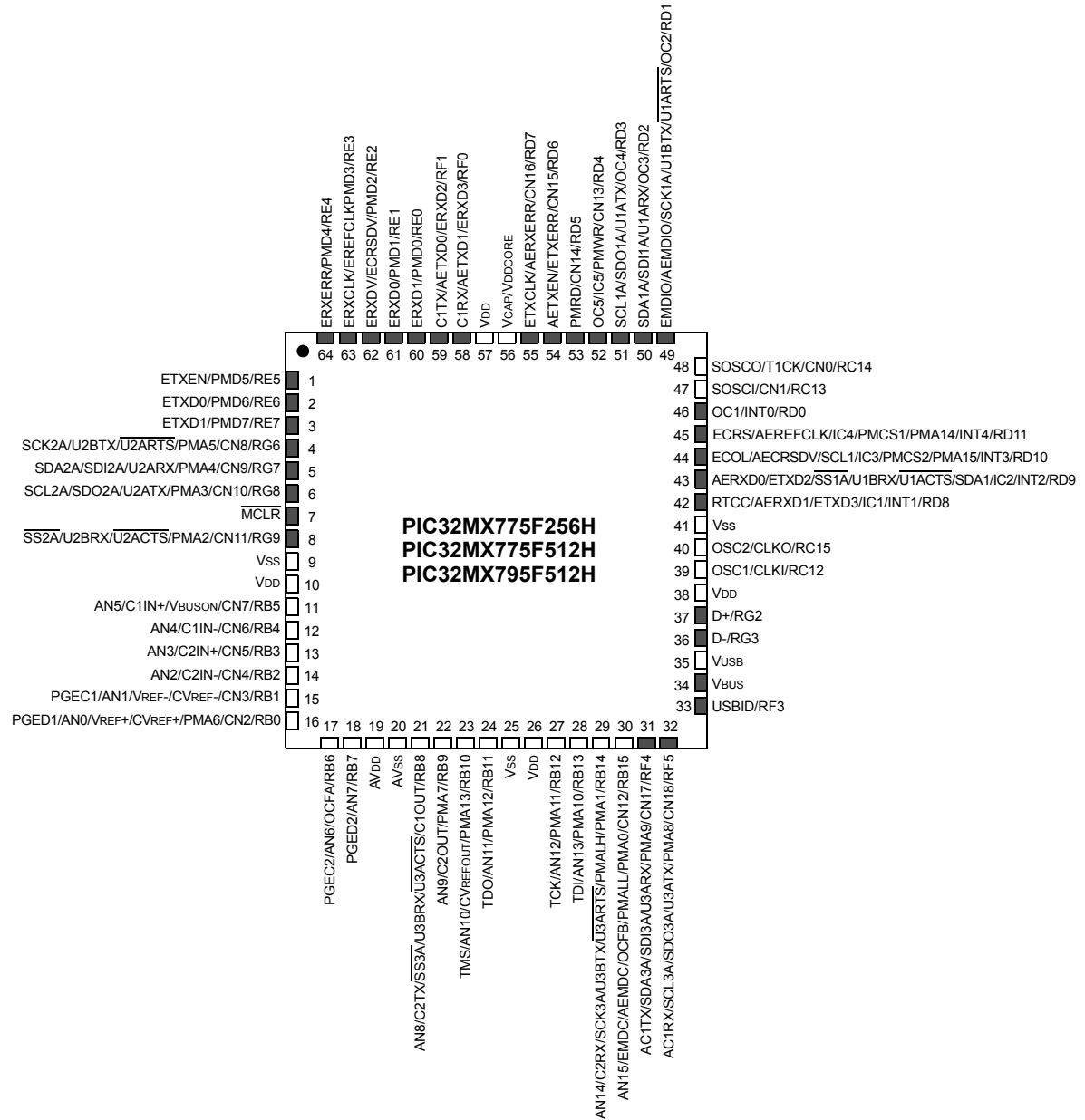




## Pin Diagrams (Continued)

### 64-Pin QFN

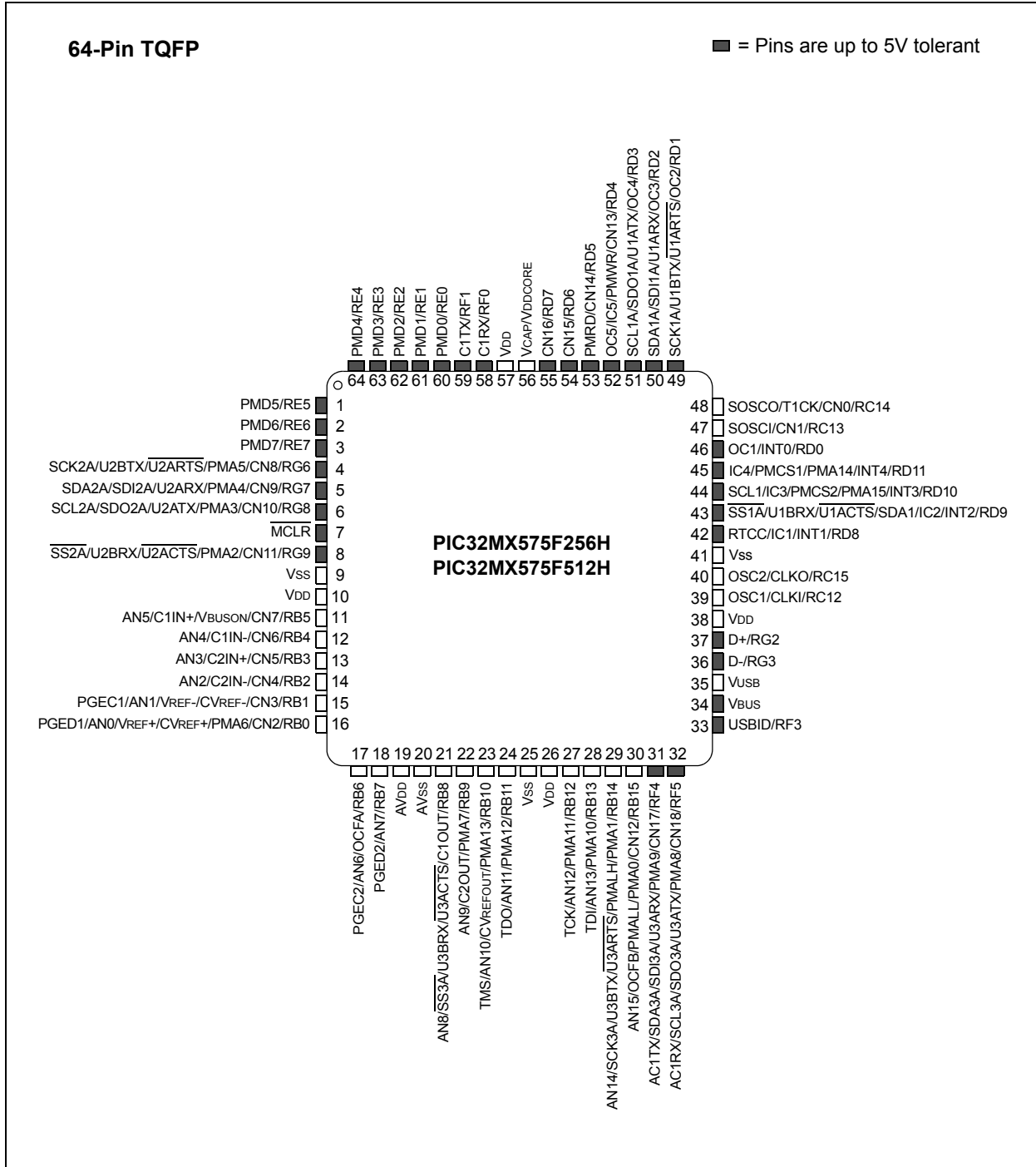
■ = Pins are up to 5V tolerant



**Note:** The metal plane at the bottom of the device is not connected to any pins and is recommended to be connected to Vss externally.

# PIC32MX5XX/6XX/7XX

## Pin Diagrams (Continued)

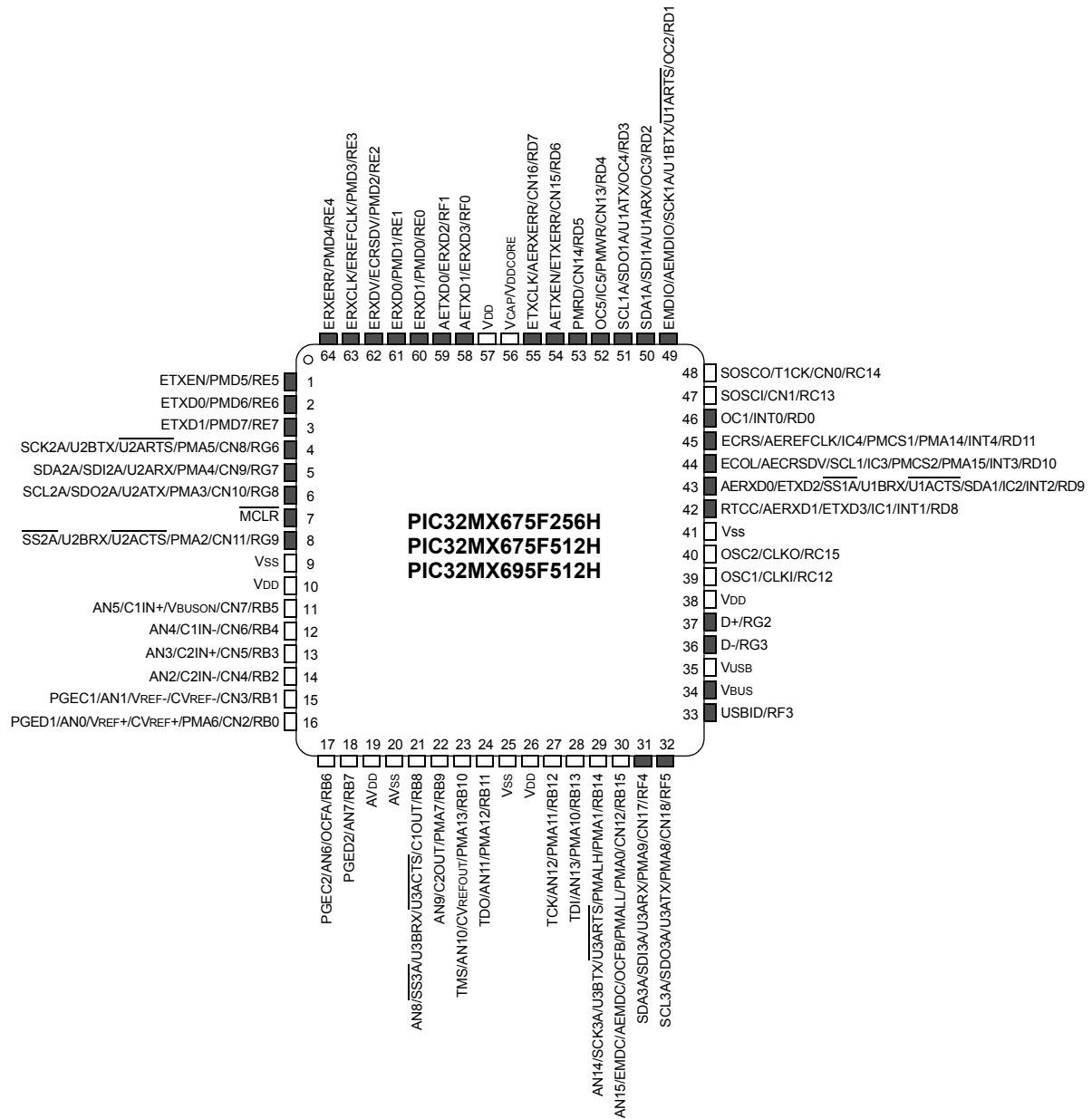


# PIC32MX5XX/6XX/7XX

## Pin Diagrams (Continued)

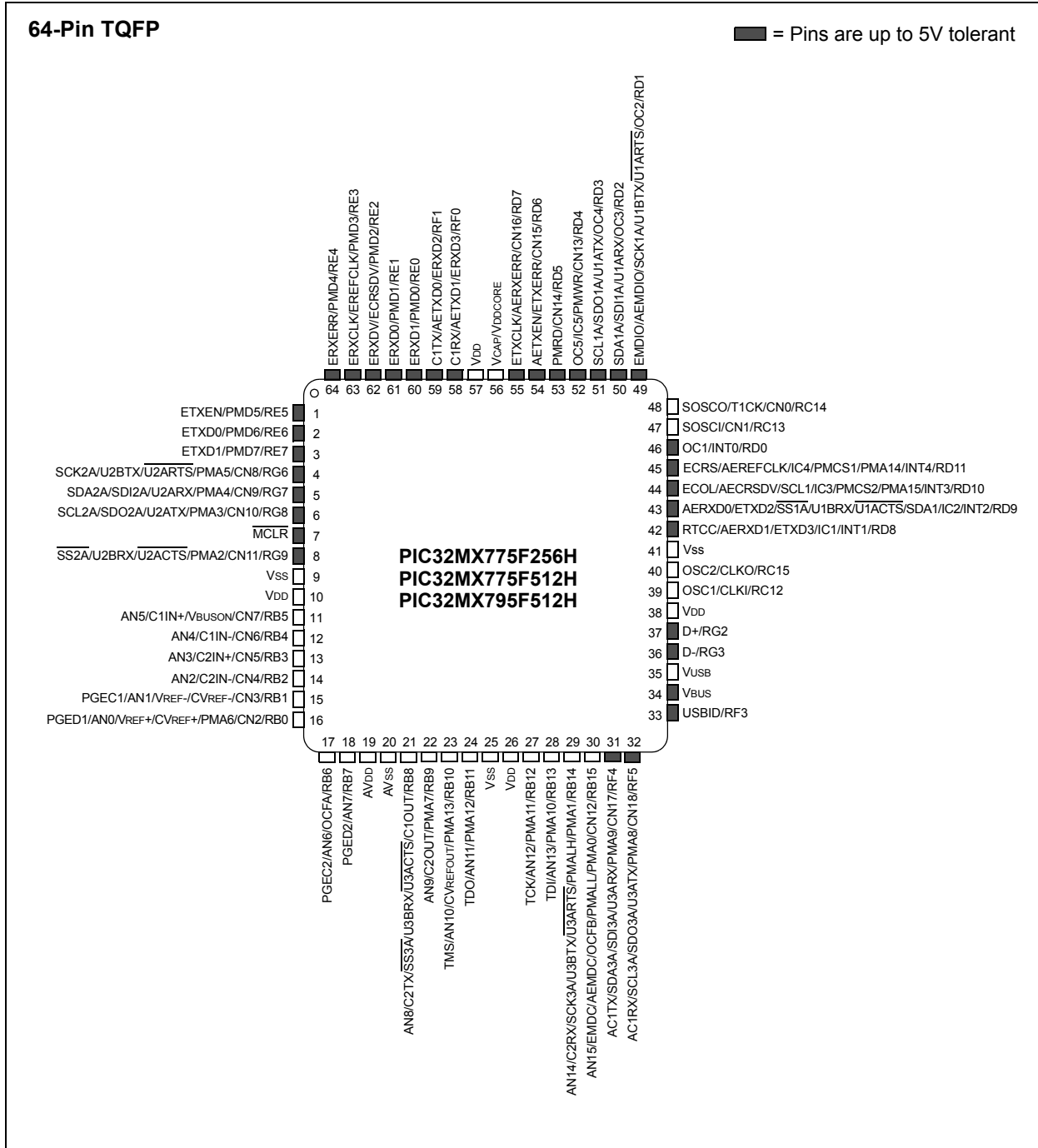
### 64-Pin TQFP

■ = Pins are up to 5V tolerant



# PIC32MX5XX/6XX/7XX


## Pin Diagrams (Continued)

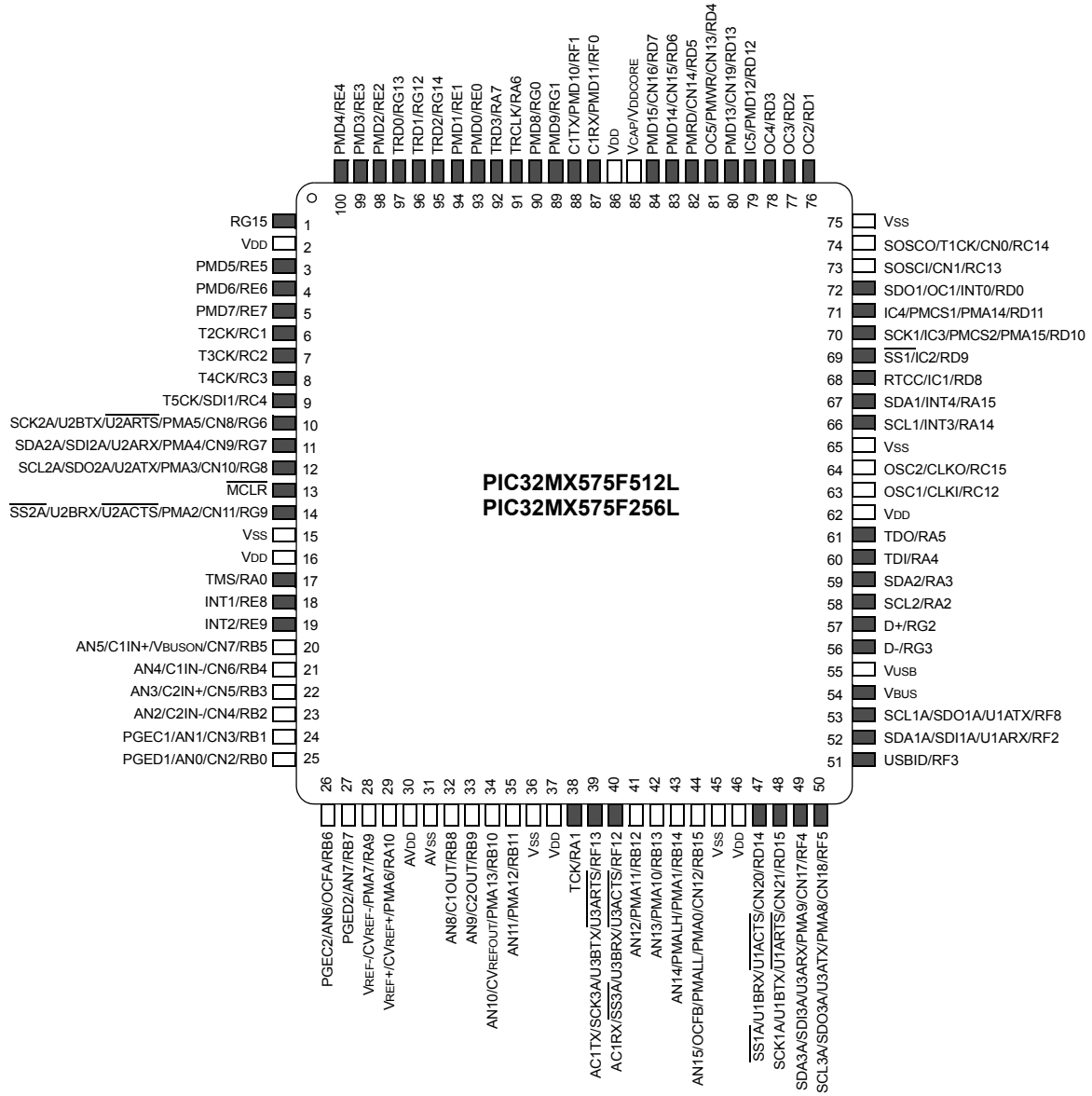


# PIC32MX5XX/6XX/7XX

## Pin Diagrams (Continued)

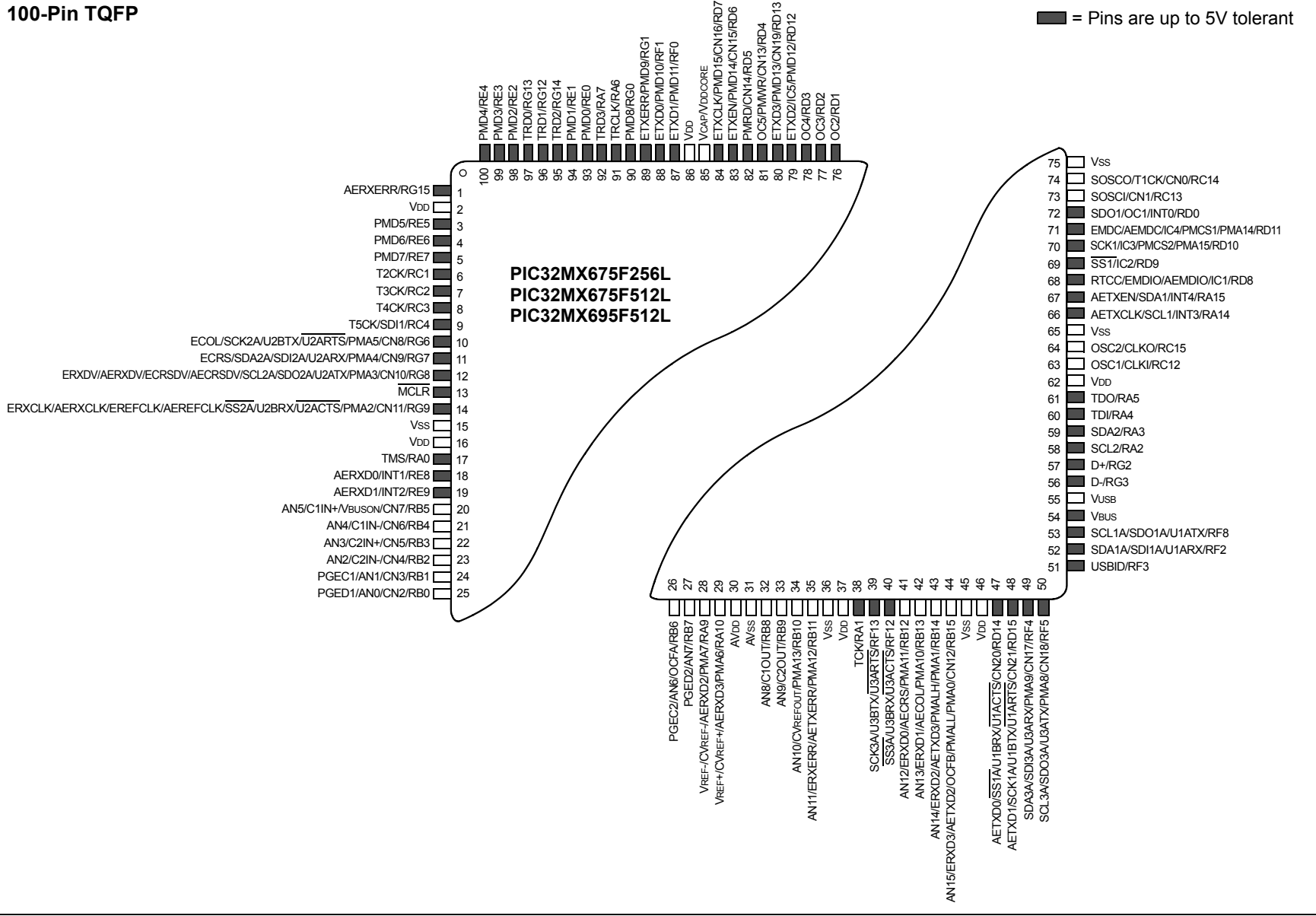
### 100-Pin TQFP

 = Pins are up to 5V tolerant



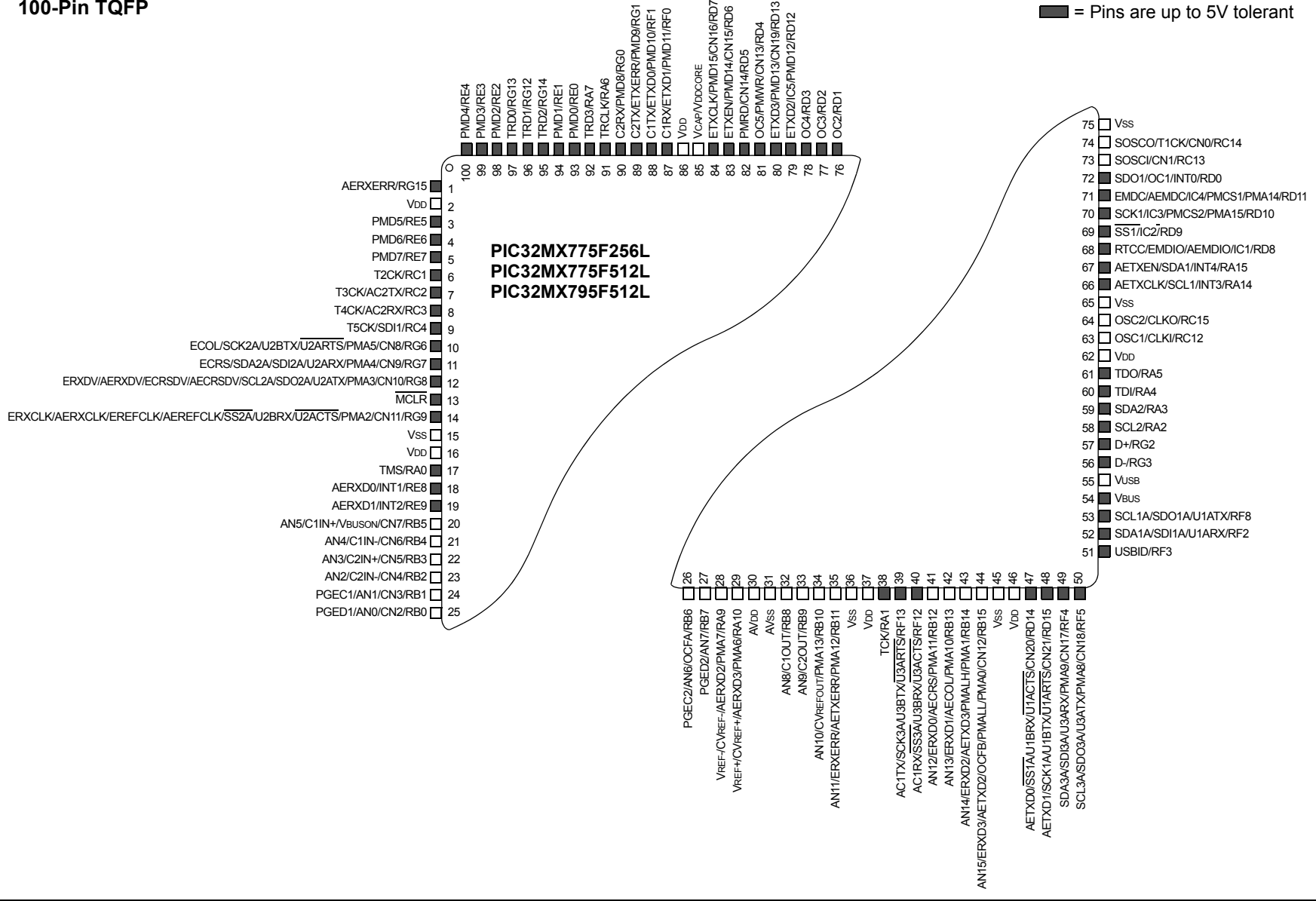
# Pin Diagrams (Continued)

## 100-Pin TQFP



### Pin Diagrams (Continued)

#### 100-Pin TQFP



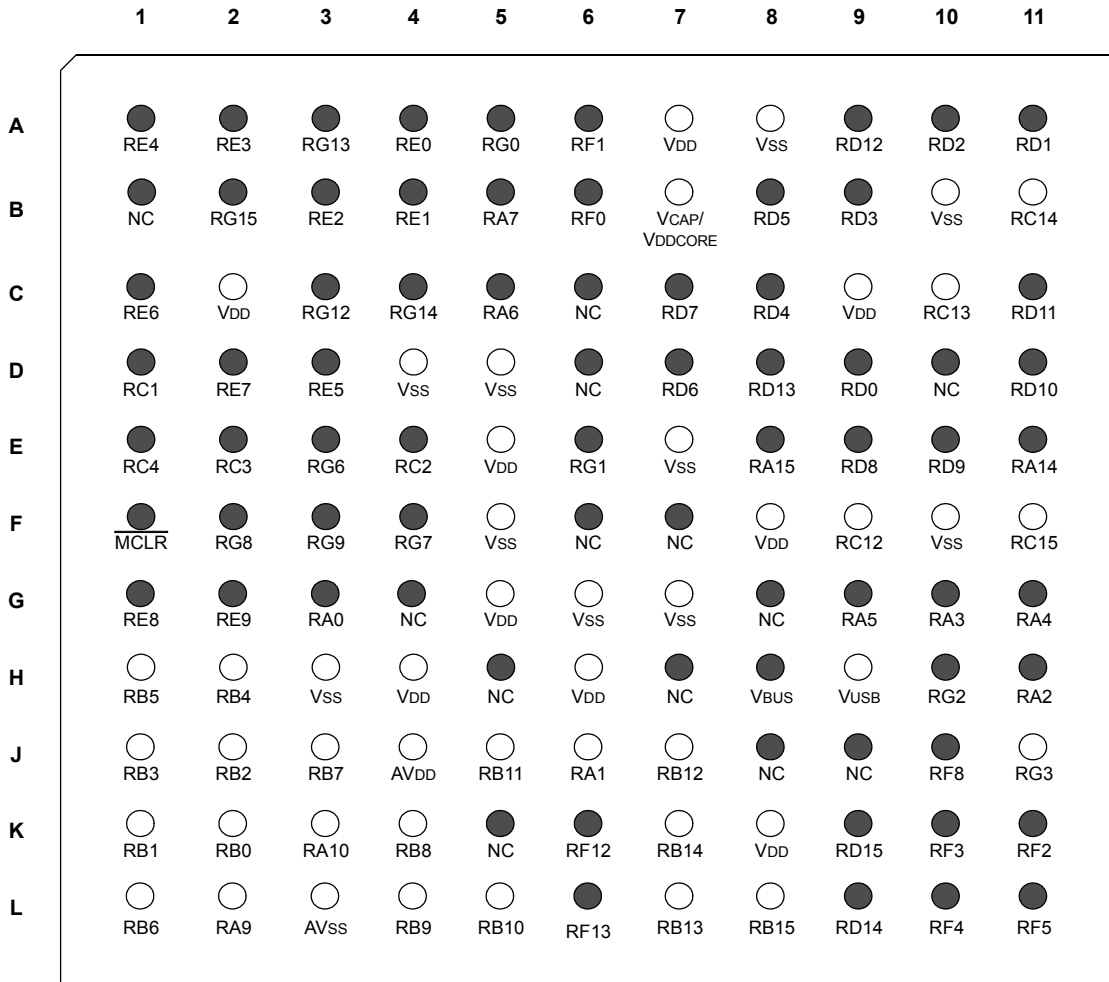
# PIC32MX5XX/6XX/7XX

## Pin Diagrams (Continued)

121-Pin XBGA<sup>(1)</sup>

● = Pins are up to 5V tolerant

PIC32MX575F256L  
 PIC32MX675F256L  
 PIC32MX775F256L  
 PIC32MX575F512L  
 PIC32MX675F512L  
 PIC32MX695F512L  
 PIC32MX775F512L  
 PIC32MX795F512L



**Note 1:** Refer to Table 4, Table 5 and Table 6 for full pin names.



# PIC32MX5XX/6XX/7XX

**TABLE 4: PIN NAMES: PIC32MX575F256L AND PIC32MX575F512L DEVICES**

Pin Number	Full Pin Name	Pin Number	Full Pin Name
A1	PMD4/RE4	E8	SDA1/INT4/RA15
A2	PMD3/RE3	E9	RTCC/IC1/RD8
A3	TRD0/RG13	E10	$\overline{SS1}$ /IC2/RD9
A4	PMD0/RE0	E11	SCL1/INT3/RA14
A5	PMD8/RG0	F1	$\overline{MCLR}$
A6	C1TX/PMD10/RF1	F2	SCL2A/SDO2A/U2ATX/PMA3/CN10/RG8
A7	VDD	F3	$\overline{SS2A}$ /U2BRX/U2ACTS/PMA2/CN11/RG9
A8	VSS	F4	SDA2A/SDI2A/U2ARX/PMA4/CN9/RG7
A9	IC5/PMD12/RD12	F5	VSS
A10	OC3/RD2	F6	No Connect (NC)
A11	OC2/RD1	F7	No Connect (NC)
B1	No Connect (NC)	F8	VDD
B2	RG15	F9	OSC1/CLKI/RC12
B3	PMD2/RE2	F10	VSS
B4	PMD1/RE1	F11	OSC2/CLKO/RC15
B5	TRD3/RA7	G1	INT1/RE8
B6	C1RX/PMD11/RF0	G2	INT2/RE9
B7	VCAP/VDDCORE	G3	TMS/RA0
B8	PMRD/CN14/RD5	G4	No Connect (NC)
B9	OC4/RD3	G5	VDD
B10	VSS	G6	VSS
B11	SOSCO/T1CK/CN0/RC14	G7	VSS
C1	PMD6/RE6	G8	No Connect (NC)
C2	VDD	G9	TDO/RA5
C3	TRD1/RG12	G10	SDA2/RA3
C4	TRD2/RG14	G11	TDI/RA4
C5	TRCLK/RA6	H1	AN5/C1IN+/VBUS0N/CN7/RB5
C6	No Connect (NC)	H2	AN4/C1IN-/CN6/RB4
C7	PMD15/CN16/RD7	H3	VSS
C8	OC5/PMWR/CN13/RD4	H4	VDD
C9	VDD	H5	No Connect (NC)
C10	SOSCI/CN1/RC13	H6	VDD
C11	IC4/PMCS1/PMA14/RD11	H7	No Connect (NC)
D1	T2CK/RC1	H8	VBus
D2	PMD7/RE7	H9	VUSB
D3	PMD5/RE5	H10	D+/RG2
D4	VSS	H11	SCL2/RA2
D5	VSS	J1	AN3/C2IN+/CN5/RB3
D6	No Connect (NC)	J2	AN2/C2IN-/CN4/RB2
D7	PMD14/CN15/RD6	J3	PGED2/AN7/RB7
D8	PMD13/CN19/RD13	J4	AVDD
D9	SDO1/OC1/INT0/RD0	J5	AN11/PMA12/RB11
D10	No Connect (NC)	J6	TCK/RA1
D11	SCK1/IC3/PMCS2/PMA15/RD10	J7	AN12/PMA11/RB12
E1	T5CK/SDI1/RC4	J8	No Connect (NC)
E2	T4CK/RC3	J9	No Connect (NC)
E3	SCK2A/U2BTX/U2ARTS/PMA5/CN8/RG6	J10	SCL1A/SDO1A/U1ATX/RF8
E4	T3CK/RC2	J11	D-/RG3
E5	VDD	K1	PGEC1/AN1/CN3/RB1
E6	PMD9/RG1	K2	PGED1/AN0/CN2/RB0
E7	VSS	K3	VREF+/CVREF+/PMA6/RA10

# PIC32MX5XX/6XX/7XX

**TABLE 4: PIN NAMES: PIC32MX575F256L AND PIC32MX575F512L DEVICES (CONTINUED)**

Pin Number	Full Pin Name
K4	AN8/C1OUT/RB8
K5	No Connect (NC)
K6	AC1RX/ $\overline{SS3A}$ /U3BRX/ $\overline{U3ACTS}$ /RF12
K7	AN14/PMALH/PMA1/RB14
K8	VDD
K9	SCK1A/U1BTX/ $\overline{U1ARTS}$ /CN21/RD15
K10	USBID/RF3
K11	SDA1A/SDI1A/U1ARX/RF2
L1	PGEC2/AN6/OCFA/RB6
L2	VREF-/CVREF-/PMA7/RA9

Pin Number	Full Pin Name
L3	AVSS
L4	AN9/C2OUT/RB9
L5	AN10/CVREFOUT/PMA13/RB10
L6	AC1TX/SCK3A/U3BTX/ $\overline{U3ARTS}$ /RF13
L7	AN13/PMA10/RB13
L8	AN15/OCFB/PMALL/PMA0/CN12/RB15
L9	$\overline{SS1A}$ /U1BRX/ $\overline{U1ACTS}$ /CN20/RD14
L10	SDA3A/SDI3A/U3ARX/PMA9/CN17/RF4
L11	SCL3A/SDO3A/U3ATX/PMA8/CN18/RF5

# PIC32MX5XX/6XX/7XX

**TABLE 5: PIN NAMES: PIC32MX675F256L, PIC32MX675F512L AND PIC32MX695F512L DEVICES**

Pin Number	Full Pin Name
A1	PMD4/RE4
A2	PMD3/RE3
A3	TRD0/RG13
A4	PMD0/RE0
A5	PMD8/RG0
A6	ETXD0/PMD10/RF1
A7	V <sub>DD</sub>
A8	V <sub>SS</sub>
A9	ETXD2/IC5/PMD12/RD12
A10	OC3/RD2
A11	OC2/RD1
B1	No Connect (NC)
B2	AERXERR/RG15
B3	PMD2/RE2
B4	PMD1/RE1
B5	TRD3/RA7
B6	ETXD1/PMD11/RF0
B7	VCAP/VDDCORE
B8	PMRD/CN14/RD5
B9	OC4/RD3
B10	V <sub>SS</sub>
B11	SOSCO/T1CK/CN0/RC14
C1	PMD6/RE6
C2	V <sub>DD</sub>
C3	TRD1/RG12
C4	TRD2/RG14
C5	TRCLK/RA6
C6	No Connect (NC)
C7	ETXCLK/PMD15/CN16/RD7
C8	OC5/PMWR/CN13/RD4
C9	V <sub>DD</sub>
C10	SOSCI/CN1/RC13
C11	EMDC/AEMDC/IC4/PMCS1/PMA14/RD11
D1	T2CK/RC1
D2	PMD7/RE7
D3	PMD5/RE5
D4	V <sub>SS</sub>
D5	V <sub>SS</sub>
D6	No Connect (NC)
D7	ETXEN/PMD14/CN15/RD6
D8	ETXD3/PMD13/CN19/RD13
D9	SDO1/OC1/INT0/RD0
D10	No Connect (NC)
D11	SCK1/IC3/PMCS2/PMA15/RD10
E1	T5CK/SDI1/RC4
E2	T4CK/RC3
E3	ECOL/SCK2A/U2BTX/U2ARTS/PMA5/CN8/RG6
E4	T3CK/RC2
E5	V <sub>DD</sub>
E6	ETXERR/PM9/RG1
E7	V <sub>SS</sub>

Pin Number	Full Pin Name
E8	AETXEN/SDA1/INT4/RA15
E9	RTCC/EMDIO/AEMDIO/IC1/RD8
E10	SS1/IC2/RD9
E11	AETXCLK/SCL1/INT3/RA14
F1	MCLR
F2	ERXDV/AERXDV/ECRS/SDV/AECRS/SDV//SCL2A/SDO2A/ U2ATX/PMA3/CN10/RG8
F3	ERXCLK/AERXCLK/EREFCLK/AEREFCLK//SS2A/U2BRX/ U2ACTS/PMA2/CN11/RG9
F4	ECS/SDA2A/SDI2A/U2ARX/PMA4/CN9/RG7
F5	V <sub>SS</sub>
F6	No Connect (NC)
F7	No Connect (NC)
F8	V <sub>DD</sub>
F9	OSC1/CLKI/RC12
F10	V <sub>SS</sub>
F11	OSC2/CLKO/RC15
G1	AERXD0/INT1/RE8
G2	AERXD1/INT2/RE9
G3	TMS/RA0
G4	No Connect (NC)
G5	V <sub>DD</sub>
G6	V <sub>SS</sub>
G7	V <sub>SS</sub>
G8	No Connect (NC)
G9	TDO/RA5
G10	SDA2/RA3
G11	TDI/RA4
H1	AN5/C1IN+/VBUSON/CN7/RB5
H2	AN4/C1IN-/CN6/RB4
H3	V <sub>SS</sub>
H4	V <sub>DD</sub>
H5	No Connect (NC)
H6	V <sub>DD</sub>
H7	No Connect (NC)
H8	VBUS
H9	VUSB
H10	D+/RG2
H11	SCL2/RA2
J1	AN3/C2IN+/CN5/RB3
J2	AN2/C2IN-/CN4/RB2
J3	PGED2/AN7/RB7
J4	AVDD
J5	AN11/ERXERR/AETXERR/PMA12/RB11
J6	TCK/RA1
J7	AN12/ERXD0/AECRS/PMA11/RB12
J8	No Connect (NC)
J9	No Connect (NC)
J10	SCL1A/SDO1A/U1ATX/RF8
J11	D-/RG3
K1	PGEC1/AN1/CN3/RB1
K2	PGED1/AN0/CN2/RB0
K3	VREF+/CVREF+/AERXD3/PMA6/RA10

# PIC32MX5XX/6XX/7XX

**TABLE 5: PIN NAMES: PIC32MX675F256L, PIC32MX675F512L AND PIC32MX695F512L DEVICES**

Pin Number	Full Pin Name
K4	AN8/C1OUT/RB8
K5	No Connect (NC)
K6	SS3A/U3BRX/U3ACTS/RF12
K7	AN14/ERXD2/AETXD3/PMALH/PMA1/RB14
K8	VDD
K9	AETXD1/SCK1A/U1BTX/U1ARTS/CN21/RD15
K10	USBID/RF3
K11	SDA1A/SDI1A/U1ARX/RF2
L1	PGEC2/AN6/OCFA/RB6
L2	VREF-JCVREF-/AERXD2/PMA7/RA9

Pin Number	Full Pin Name
L3	AVss
L4	AN9/C2OUT/RB9
L5	AN10/CVREFOUT/PMA13/RB10
L6	SCK3A/U3BTX/U3ARTS/RF13
L7	AN13/ERXD1/AECOL/PMA10/RB13
L8	AN15/ERXD3/AETXD2/OCFB/PMALL/PMA0/CN12/RB15
L9	AETXD0/SS1A/U1BRX/U1ACTS/CN20/RD14
L10	SDA3A/SDI3A/U3ARX/PMA9/CN17/RF4
L11	SCL3A/SDO3A/U3ATX/PMA8/CN18/RF5

# PIC32MX5XX/6XX/7XX

**TABLE 6: PIN NAMES: PIC32MX775F256L, PIC32MX775F512L AND PIC32MX795F512L DEVICES**

Pin Number	Full Pin Name
A1	PMD4/RE4
A2	PMD3/RE3
A3	TRD0/RG13
A4	PMD0/RE0
A5	C2RX/PMD8/RG0
A6	C1TX/ETXD0/PMD10/RF1
A7	VDD
A8	VSS
A9	ETXD2/IC5/PMD12/RD12
A10	OC3/RD2
A11	OC2/RD1
B1	No Connect (NC)
B2	AERXERR/RG15
B3	PMD2/RE2
B4	PMD1/RE1
B5	TRD3/RA7
B6	C1RX/ETXD1/PMD11/RF0
B7	VCAP/VDDCORE
B8	PMRD/CN14/RD5
B9	OC4/RD3
B10	VSS
B11	SOSCO/T1CK/CN0/RC14
C1	PMD6/RE6
C2	VDD
C3	TRD1/RG12
C4	TRD2/RG14
C5	TRCLK/RA6
C6	No Connect (NC)
C7	ETXCLK/PMD15/CN16/RD7
C8	OC5/PMWR/CN13/RD4
C9	VDD
C10	SOSCI/CN1/RC13
C11	EMDC/AEMDC/IC4/PMCS1/PMA14/RD11
D1	T2CK/RC1
D2	PMD7/RE7
D3	PMD5/RE5
D4	VSS
D5	VSS
D6	No Connect (NC)
D7	ETXEN/PMD14/CN15/RD6
D8	ETXD3/PMD13/CN19/RD13
D9	SDO1/OC1/INT0/RD0
D10	No Connect (NC)
D11	SCK1/IC3/PMCS2/PMA15/RD10
E1	T5CK/SD1/RC4
E2	T4CK/AC2RX/RC3
E3	ECOL/SCK2A/U2BTX/U2ARTS/PMA5/CN8/RG6
E4	T3CK/AC2TX/RC2
E5	VDD
E6	C2TX/ETXERR/PMD9/RG1
E7	VSS

Pin Number	Full Pin Name
E8	AETXEN/SDA1/INT4/RA15
E9	RTCC/EMDIO/AEMDIO/IC1/RD8
E10	SS1/IC2/RD9
E11	AETXCLK/SCL1/INT3/RA14
F1	MCLR
F2	ERXDV/AERXDV/ECRSDV/AECRSDV/SCL2A/SDO2A/U2ATX/PMA3/CN10/RG8
F3	ERXCLK/AERXCLK/EREFCLK/AEREFCLK/SS2A/U2BRX/U2ACTS/PMA2/CN11/RG9
F4	ECRS/SDA2A/SDI2A/U2ARX/PMA4/CN9/RG7
F5	VSS
F6	No Connect (NC)
F7	No Connect (NC)
F8	VDD
F9	OSC1/CLKI/RC12
F10	VSS
F11	OSC2/CLKO/RC15
G1	AERXD0/INT1/RE8
G2	AERXD1/INT2/RE9
G3	TMS/RA0
G4	No Connect (NC)
G5	VDD
G6	VSS
G7	VSS
G8	No Connect (NC)
G9	TDO/RA5
G10	SDA2/RA3
G11	TDI/RA4
H1	AN5/C1IN+/VBUSON/CN7/RB5
H2	AN4/C1IN-/CN6/RB4
H3	VSS
H4	VDD
H5	No Connect (NC)
H6	VDD
H7	No Connect (NC)
H8	VBus
H9	VUSB
H10	D+/RG2
H11	SCL2/RA2
J1	AN3/C2IN+/CN5/RB3
J2	AN2/C2IN-/CN4/RB2
J3	PGED2/AN7/RB7
J4	AVDD
J5	AN11/ERXERR/AETXERR/PMA12/RB11
J6	TCK/RA1
J7	AN12/ERXD0/AECRS/PMA11/RB12
J8	No Connect (NC)
J9	No Connect (NC)
J10	SCL1A/SDO1A/U1ATX/RF8
J11	D-/RG3
K1	PGEC1/AN1/CN3/RB1
K2	PGED1/AN0/CN2/RB0
K3	VREF+/CVREF+/AERXD3/PMA6/RA10

# PIC32MX5XX/6XX/7XX

**TABLE 6: PIN NAMES: PIC32MX775F256L, PIC32MX775F512L AND PIC32MX795F512L DEVICES**

Pin Number	Full Pin Name
K4	AN8/C1OUT/RB8
K5	No Connect (NC)
K6	AC1RX/SS3A/U3BRX/U3ACTS/RF12
K7	AN14/ERXD2/AETXD3/PMALH/PMA1/RB14
K8	VDD
K9	AETXD1/SCK1A/U1BTX/U1ARTS/CN21/RD15
K10	USBID/RF3
K11	SDA1A/SDI1A/U1ARX/RF2
L1	PGEC2/AN6/OCFA/RB6
L2	VREF/CVREF-JAERXD2/PMA7/RA9

Pin Number	Full Pin Name
L3	AVss
L4	AN9/C2OUT/RB9
L5	AN10/CVREFOUT/PMA13/RB10
L6	AC1TX/SCK3A/U3BTX/U3ARTS/RF13
L7	AN13/ERXD1/AECOL/PMA10/RB13
L8	AN15/ERXD3/AETXD2/OCFB/PMALL/PMA0/CN12/RB15
L9	AETXD0/SS1A/U1BRX/U1ACTS/CN20/RD14
L10	SDA3A/SDI3A/U3ARX/PMA9/CN17/RF4
L11	SCL3A/SDO3A/U3ATX/PMA8/CN18/RF5

## Table of Contents

1.0	Device Overview .....	25
2.0	Guidelines for Getting Started with 32-bit Microcontrollers .....	37
3.0	PIC32MX MCU .....	41
4.0	Memory Organization .....	47
5.0	Flash Program Memory .....	107
6.0	Resets .....	109
7.0	Interrupt Controller .....	111
8.0	Oscillator Configuration .....	115
9.0	Prefetch Cache .....	117
10.0	Direct Memory Access (DMA) Controller .....	119
11.0	USB On-The-Go (OTG) .....	121
12.0	I/O Ports .....	123
13.0	Timer1 .....	125
14.0	Timer2/3, Timer4/5 .....	127
15.0	Input Capture .....	129
16.0	Output Compare .....	131
17.0	Serial Peripheral Interface (SPI) .....	133
18.0	Inter-Integrated Circuit (I <sup>2</sup> C™) .....	135
19.0	Universal Asynchronous Receiver Transmitter (UART) .....	137
20.0	Parallel Master Port (PMP) .....	139
21.0	Real-Time Clock and Calendar (RTCC) .....	141
22.0	10-bit Analog-to-Digital Converter (ADC) .....	143
23.0	Controller Area Network (CAN) .....	145
24.0	Ethernet Controller .....	147
25.0	Comparator .....	149
26.0	Comparator Voltage Reference (CVREF) .....	151
27.0	Power-Saving Features .....	153
28.0	Special Features .....	155
29.0	Instruction Set .....	167
30.0	Development Support .....	169
31.0	Electrical Characteristics .....	173
32.0	Packaging Information .....	215
	Index .....	235

## TO OUR VALUED CUSTOMERS

It is our intention to provide our valued customers with the best documentation possible to ensure successful use of your Microchip products. To this end, we will continue to improve our publications to better suit your needs. Our publications will be refined and enhanced as new volumes and updates are introduced.

If you have any questions or comments regarding this publication, please contact the Marketing Communications Department via E-mail at [docerrors@microchip.com](mailto:docerrors@microchip.com) or fax the **Reader Response Form** in the back of this data sheet to (480) 792-4150. We welcome your feedback.

### Most Current Data Sheet

To obtain the most up-to-date version of this data sheet, please register at our Worldwide Web site at:

<http://www.microchip.com>

You can determine the version of a data sheet by examining its literature number found on the bottom outside corner of any page. The last character of the literature number is the version number, (e.g., DS30000A is version A of document DS30000).

### Errata

An errata sheet, describing minor operational differences from the data sheet and recommended workarounds, may exist for current devices. As device/documentation issues become known to us, we will publish an errata sheet. The errata will specify the revision of silicon and revision of document to which it applies.

To determine if an errata sheet exists for a particular device, please check with one of the following:

- Microchip's Worldwide Web site; <http://www.microchip.com>
- Your local Microchip sales office (see last page)

When contacting a sales office, please specify which device, revision of silicon and data sheet (include literature number) you are using.

### Customer Notification System

Register on our web site at [www.microchip.com](http://www.microchip.com) to receive the most current information on all of our products.

# PIC32MX5XX/6XX/7XX

---

NOTES:



# PIC32MX5XX/6XX/7XX

## 1.0 DEVICE OVERVIEW

**Note 1:** This data sheet summarizes the features of the PIC32MX5XX/6XX/7XX family of devices. It is not intended to be a comprehensive reference source. To complement the information in this data sheet, refer to the related section of the “PIC32MX Family Reference Manual”, which is available from the Microchip web site ([www.microchip.com/PIC32](http://www.microchip.com/PIC32)).

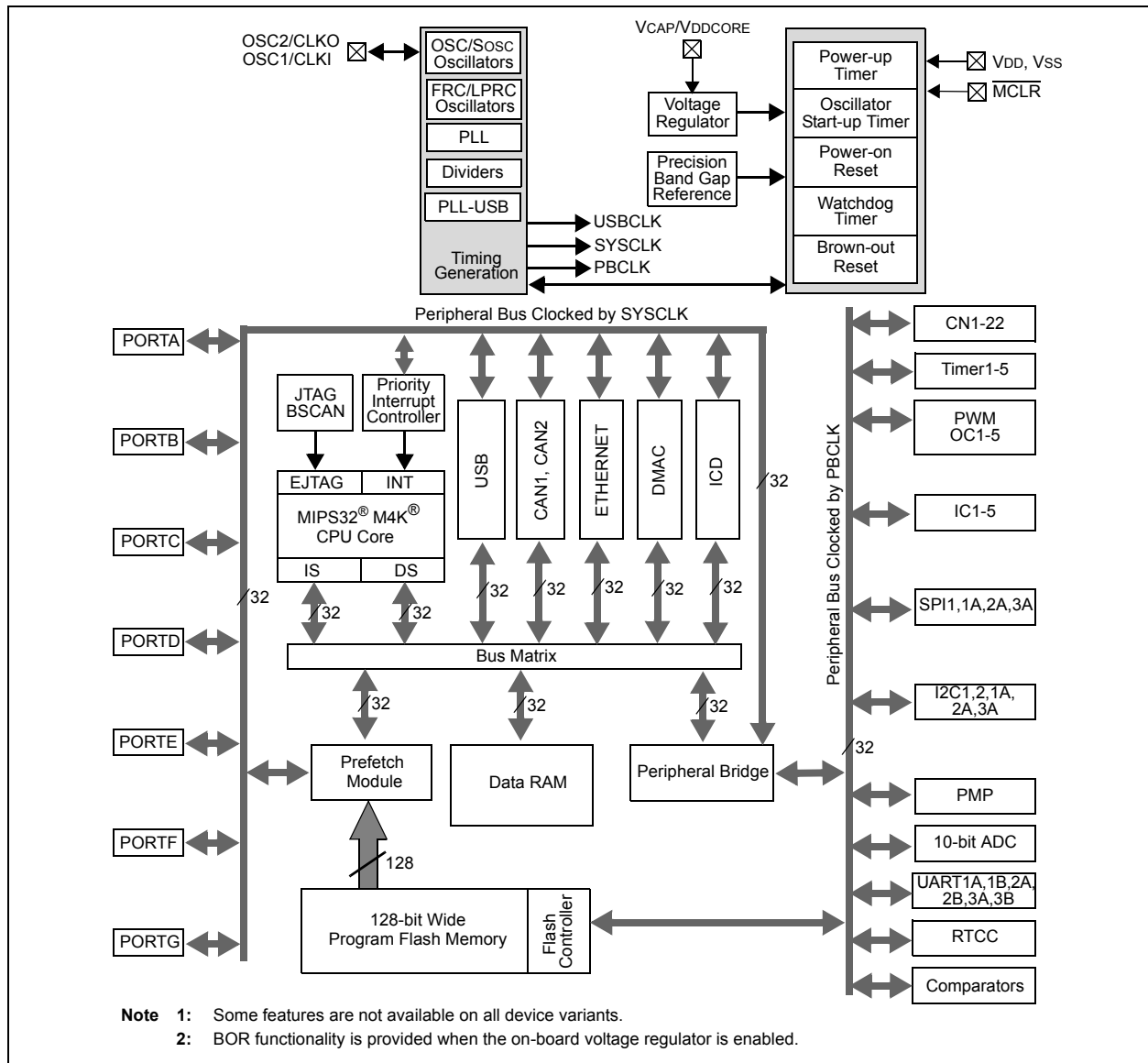
**2:** Some registers and associated bits described in this section may not be available on all devices. Refer to **Section 4.0 “Memory Organization”** in this data sheet for device-specific register and bit information.

This document contains device-specific information for PIC32MX5XX/6XX/7XX devices.

Figure 1-1 illustrates a general block diagram of the core and peripheral modules in the PIC32MX5XX/6XX/7XX family of devices.

Table 1-1 lists the functions of the various pins shown in the pinout diagrams.

**FIGURE 1-1: BLOCK DIAGRAM<sup>(1,2)</sup>**



# PIC32MX5XX/6XX/7XX

**TABLE 1-1: PINOUT I/O DESCRIPTIONS**

Pin Name	Pin Number <sup>(1)</sup>			Pin Type	Buffer Type	Description
	64-Pin QFN/TQFP	100-Pin TQFP	121-Pin XBGA			
AN0	16	25	K2	I	Analog	Analog input channels.
AN1	15	24	K1	I	Analog	
AN2	14	23	J2	I	Analog	
AN3	13	22	J1	I	Analog	
AN4	12	21	H2	I	Analog	
AN5	11	20	H1	I	Analog	
AN6	17	26	L1	I	Analog	
AN7	18	27	J3	I	Analog	
AN8	21	32	K4	I	Analog	
AN9	22	33	L4	I	Analog	
AN10	23	34	L5	I	Analog	
AN11	24	35	J5	I	Analog	
AN12	27	41	J7	I	Analog	
AN13	28	42	L7	I	Analog	
AN14	29	43	K7	I	Analog	
AN15	30	44	L8	I	Analog	
CLKI	39	63	F9	I	ST/CMOS	External clock source input. Always associated with OSC1 pin function.
CLKO	40	64	F11	O	—	Oscillator crystal output. Connects to crystal or resonator in Crystal Oscillator mode. Optionally functions as CLKO in RC and EC modes. Always associated with OSC2 pin function.
OSC1	39	63	F9	I	ST/CMOS	Oscillator crystal input. ST buffer when configured in RC mode; CMOS otherwise.
OSC2	40	64	F11	I/O	—	Oscillator crystal output. Connects to crystal or resonator in Crystal Oscillator mode. Optionally functions as CLKO in RC and EC modes.
SOSCI	47	73	C10	I	ST/CMOS	32.768 kHz low-power oscillator crystal input; CMOS otherwise.
SOSCO	48	74	B11	O	—	32.768 kHz low-power oscillator crystal output.

**Legend:** CMOS = CMOS compatible input or output      Analog = Analog input      P = Power  
 ST = Schmitt Trigger input with CMOS levels      O = Output      I = Input  
 TTL = TTL input buffer

- Note 1:** Pin numbers are provided for reference only. See the “Pin Diagrams” section for device pin availability.  
**2:** See Section 24.0 “Ethernet Controller” for more information.

# PIC32MX5XX/6XX/7XX

**TABLE 1-1: PINOUT I/O DESCRIPTIONS (CONTINUED)**

Pin Name	Pin Number <sup>(1)</sup>			Pin Type	Buffer Type	Description
	64-Pin QFN/TQFP	100-Pin TQFP	121-Pin XBGA			
CN0	48	74	B11	I	ST	Change notification inputs. Can be software programmed for internal weak pull-ups on all inputs.
CN1	47	73	C10	I	ST	
CN2	16	25	K2	I	ST	
CN3	15	24	K1	I	ST	
CN4	14	23	J2	I	ST	
CN5	13	22	J1	I	ST	
CN6	12	21	H2	I	ST	
CN7	11	20	H1	I	ST	
CN8	4	10	E3	I	ST	
CN9	5	11	F4	I	ST	
CN10	6	12	F2	I	ST	
CN11	8	14	F3	I	ST	
CN12	30	44	L8	I	ST	
CN13	52	81	C8	I	ST	
CN14	53	82	B8	I	ST	
CN15	54	83	D7	I	ST	
CN16	55	84	C7	I	ST	
CN17	31	49	L10	I	ST	
CN18	32	50	L11	I	ST	
CN19	—	80	D8	I	ST	
CN20	—	47	L9	I	ST	
CN21	—	48	K9	I	ST	
IC1	42	68	E9	I	ST	Capture Inputs 1-5.
IC2	43	69	E10	I	ST	
IC3	44	70	D11	I	ST	
IC4	45	71	C11	I	ST	
IC5	52	79	A9	I	ST	
OCFA	17	26	L1	I	ST	Output Compare Fault A Input.
OC1	46	72	D9	O	—	Output Compare Output 1.
OC2	49	76	A11	O	—	Output Compare Output 2
OC3	50	77	A10	O	—	Output Compare Output 3.
OC4	51	78	B9	O	—	Output Compare Output 4.
OC5	52	81	C8	O	—	Output Compare Output 5.
OCFB	30	44	L8	I	ST	Output Compare Fault B Input.
INT0	46	72	D9	I	ST	External Interrupt 0.
INT1	42	18	G1	I	ST	External Interrupt 1.
INT2	43	19	G2	I	ST	External Interrupt 2.
INT3	44	66	E11	I	ST	External Interrupt 3.
INT4	45	67	E8	I	ST	External Interrupt 4.

**Legend:** CMOS = CMOS compatible input or output      Analog = Analog input      P = Power  
 ST = Schmitt Trigger input with CMOS levels      O = Output      I = Input  
 TTL = TTL input buffer

**Note 1:** Pin numbers are provided for reference only. See the “Pin Diagrams” section for device pin availability.  
**2:** See Section 24.0 “Ethernet Controller” for more information.

# PIC32MX5XX/6XX/7XX

**TABLE 1-1: PINOUT I/O DESCRIPTIONS (CONTINUED)**

Pin Name	Pin Number <sup>(1)</sup>			Pin Type	Buffer Type	Description	
	64-Pin QFN/TQFP	100-Pin TQFP	121-Pin XBGA				
RA0	—	17	G3	I/O	ST	PORTA is a bidirectional I/O port.	
RA1	—	38	J6	I/O	ST		
RA2	—	58	H11	I/O	ST		
RA3	—	59	G10	I/O	ST		
RA4	—	60	G11	I/O	ST		
RA5	—	61	G9	I/O	ST		
RA6	—	91	C5	I/O	ST		
RA7	—	92	B5	I/O	ST		
RA9	—	28	L2	I/O	ST		
RA10	—	29	K3	I/O	ST		
RA14	—	66	E11	I/O	ST		
RA15	—	67	E8	I/O	ST		
RB0	16	25	K2	I/O	ST		PORTB is a bidirectional I/O port.
RB1	15	24	K1	I/O	ST		
RB2	14	23	J2	I/O	ST		
RB3	13	22	J1	I/O	ST		
RB4	12	21	H2	I/O	ST		
RB5	11	20	H1	I/O	ST		
RB6	17	26	L1	I/O	ST		
RB7	18	27	J3	I/O	ST		
RB8	21	32	K4	I/O	ST		
RB9	22	33	L4	I/O	ST		
RB10	23	34	L5	I/O	ST		
RB11	24	35	J5	I/O	ST		
RB12	27	41	J7	I/O	ST		
RB13	28	42	L7	I/O	ST		
RB14	29	43	K7	I/O	ST		
RB15	30	44	L8	I/O	ST		
RC1	—	6	D1	I/O	ST	PORTC is a bidirectional I/O port.	
RC2	—	7	E4	I/O	ST		
RC3	—	8	E2	I/O	ST		
RC4	—	9	E1	I/O	ST		
RC12	39	63	F9	I/O	ST		
RC13	47	73	C10	I/O	ST		
RC14	48	74	B11	I/O	ST		
RC15	40	64	F11	I/O	ST		

**Legend:** CMOS = CMOS compatible input or output      Analog = Analog input      P = Power  
 ST = Schmitt Trigger input with CMOS levels      O = Output      I = Input  
 TTL = TTL input buffer

**Note 1:** Pin numbers are provided for reference only. See the “Pin Diagrams” section for device pin availability.  
**2:** See Section 24.0 “Ethernet Controller” for more information.

# PIC32MX5XX/6XX/7XX

**TABLE 1-1: PINOUT I/O DESCRIPTIONS (CONTINUED)**

Pin Name	Pin Number <sup>(1)</sup>			Pin Type	Buffer Type	Description
	64-Pin QFN/TQFP	100-Pin TQFP	121-Pin XBGA			
RD0	46	72	D9	I/O	ST	PORTD is a bidirectional I/O port.
RD1	49	76	A11	I/O	ST	
RD2	50	77	A10	I/O	ST	
RD3	51	78	B9	I/O	ST	
RD4	52	81	C8	I/O	ST	
RD5	53	82	B8	I/O	ST	
RD6	54	83	D7	I/O	ST	
RD7	55	84	C7	I/O	ST	
RD8	42	68	E9	I/O	ST	
RD9	43	69	E10	I/O	ST	
RD10	44	70	D11	I/O	ST	
RD11	45	71	C11	I/O	ST	
RD12	—	79	A9	I/O	ST	
RD13	—	80	D8	I/O	ST	
RD14	—	47	L9	I/O	ST	
RD15	—	48	K9	I/O	ST	
RE0	60	93	A4	I/O	ST	PORTE is a bidirectional I/O port.
RE1	61	94	B4	I/O	ST	
RE2	62	98	B3	I/O	ST	
RE3	63	99	A2	I/O	ST	
RE4	64	100	A1	I/O	ST	
RE5	1	3	D3	I/O	ST	
RE6	2	4	C1	I/O	ST	
RE7	3	5	D2	I/O	ST	
RE8	—	18	G1	I/O	ST	
RE9	—	19	G2	I/O	ST	
RF0	58	87	B6	I/O	ST	PORTF is a bidirectional I/O port.
RF1	59	88	A6	I/O	ST	
RF2	—	52	K11	I/O	ST	
RF3	33	51	K10	I/O	ST	
RF4	31	49	L10	I/O	ST	
RF5	32	50	L11	I/O	ST	
RF8	—	53	J10	I/O	ST	
RF12	—	40	K6	I/O	ST	
RF13	—	39	L6	I/O	ST	

**Legend:** CMOS = CMOS compatible input or output      Analog = Analog input      P = Power  
 ST = Schmitt Trigger input with CMOS levels      O = Output      I = Input  
 TTL = TTL input buffer

**Note 1:** Pin numbers are provided for reference only. See the “Pin Diagrams” section for device pin availability.  
**2:** See Section 24.0 “Ethernet Controller” for more information.

# PIC32MX5XX/6XX/7XX

**TABLE 1-1: PINOUT I/O DESCRIPTIONS (CONTINUED)**

Pin Name	Pin Number <sup>(1)</sup>			Pin Type	Buffer Type	Description
	64-Pin QFN/TQFP	100-Pin TQFP	121-Pin XBGA			
RG0	—	90	A5	I/O	ST	PORTG is a bidirectional I/O port.
RG1	—	89	E6	I/O	ST	
RG6	4	10	E3	I/O	ST	
RG7	5	11	F4	I/O	ST	
RG8	6	12	F2	I/O	ST	
RG9	8	14	F3	I/O	ST	
RG12	—	96	C3	I/O	ST	
RG13	—	97	A3	I/O	ST	
RG14	—	95	C4	I/O	ST	
RG15	—	1	B2	I/O	ST	
RG2	37	57	H10	I	ST	
RG3	36	56	J11	I	ST	
T1CK	48	74	B11	I	ST	Timer1 external clock input.
T2CK	—	6	D1	I	ST	Timer2 external clock input.
T3CK	—	7	E4	I	ST	Timer3 external clock input.
T4CK	—	8	E2	I	ST	Timer4 external clock input.
T5CK	—	9	E1	I	ST	Timer5 external clock input.
$\overline{U1ACTS}$	43	47	L9	I	ST	UART1A clear to send.
$\overline{U1ARTS}$	49	48	K9	O	—	UART1A ready to send.
U1ARX	50	52	K11	I	ST	UART1A receive.
U1ATX	51	53	J10	O	—	UART1A transmit.
$\overline{U2ACTS}$	8	14	F3	I	ST	UART2A clear to send.
$\overline{U2ARTS}$	4	10	E3	O	—	UART2A ready to send.
U2ARX	5	11	F4	I	ST	UART2A receive.
U2ATX	6	12	F2	O	—	UART2A transmit.
$\overline{U3ACTS}$	21	40	K6	I	ST	UART3A clear to send.
$\overline{U3ARTS}$	29	39	L6	O	—	UART3A ready to send.
U3ARX	31	49	L10	I	ST	UART3A receive.
U3ATX	32	50	L11	O	—	UART3A transmit.
U1BRX	43	47	L9	I	ST	UART1B receive.
U1BTX	49	48	K9	O	—	UART1B transmit.
U2BRX	8	14	F3	I	ST	UART2B receive.
U2BTX	4	10	E3	O	—	UART2B transmit.
U3BRX	21	40	K6	I	ST	UART3B receive.
U3BTX	29	39	L6	O	—	UART3B transmit.
SCK1	—	70	D11	I/O	ST	Synchronous serial clock input/output for SPI1.
SDI1	—	9	E1	I	ST	SPI1 data in.

**Legend:** CMOS = CMOS compatible input or output      Analog = Analog input      P = Power  
 ST = Schmitt Trigger input with CMOS levels      O = Output      I = Input  
 TTL = TTL input buffer

**Note 1:** Pin numbers are provided for reference only. See the “Pin Diagrams” section for device pin availability.  
**2:** See Section 24.0 “Ethernet Controller” for more information.

# PIC32MX5XX/6XX/7XX

**TABLE 1-1: PINOUT I/O DESCRIPTIONS (CONTINUED)**

Pin Name	Pin Number <sup>(1)</sup>			Pin Type	Buffer Type	Description
	64-Pin QFN/TQFP	100-Pin TQFP	121-Pin XBGA			
SDO1	—	72	D9	O	—	SPI1 data out.
SS1	—	69	E10	I/O	ST	SPI1 slave synchronization or frame pulse I/O.
SCK1A	49	48	K9	I/O	ST	Synchronous serial clock input/output for SPI1A.
SDI1A	50	52	K11	I	ST	SPI1A data in.
SDO1A	51	53	J10	O	—	SPI1A data out.
SS1A	43	47	L9	I/O	ST	SPI1A slave synchronization or frame pulse I/O.
SCK2A	4	10	E3	I/O	ST	Synchronous serial clock input/output for SPI2A.
SDI2A	5	11	F4	I	ST	SPI2A data in.
SDO2A	6	12	F2	O	—	SPI2A data out.
SS2A	8	14	F3	I/O	ST	SPI2A slave synchronization or frame pulse I/O.
SCK3A	29	39	L6	I/O	ST	Synchronous serial clock input/output for SPI3A.
SDI3A	31	49	L10	I	ST	SPI3A data in.
SDO3A	32	50	L11	O	—	SPI3A data out.
SS3A	21	40	K6	I/O	ST	SPI3A slave synchronization or frame pulse I/O.
SCL1	44	66	E11	I/O	ST	Synchronous serial clock input/output for I2C1.
SDA1	43	67	E8	I/O	ST	Synchronous serial data input/output for I2C1.
SCL1A	51	53	J10	I/O	ST	Synchronous serial clock input/output for I2C1A.
SDA1A	50	52	K11	I/O	ST	Synchronous serial data input/output for I2C1A.
SCL2	—	58	H11	I/O	ST	Synchronous serial clock input/output for I2C2.
SDA2	—	59	G10	I/O	ST	Synchronous serial data input/output for I2C2.
SCL2A	6	12	F2	I/O	ST	Synchronous serial clock input/output for I2C2A.
SDA2A	5	11	F4	I/O	ST	Synchronous serial data input/output for I2C2A.
SCL3A	32	50	L11	I/O	ST	Synchronous serial clock input/output for I2C3A.
SDA3A	31	49	L10	I/O	ST	Synchronous serial data input/output for I2C3A.
TMS	23	17	G3	I	ST	JTAG Test mode select pin.
TCK	27	38	J6	I	ST	JTAG test clock input pin.
TDI	28	60	G11	I	ST	JTAG test data input pin.
TDO	24	61	G9	O	—	JTAG test data output pin.
RTCC	42	68	E9	O	—	Real-Time Clock alarm output.

**Legend:** CMOS = CMOS compatible input or output      Analog = Analog input      P = Power  
 ST = Schmitt Trigger input with CMOS levels      O = Output      I = Input  
 TTL = TTL input buffer

**Note 1:** Pin numbers are provided for reference only. See the “Pin Diagrams” section for device pin availability.  
**2:** See Section 24.0 “Ethernet Controller” for more information.

# PIC32MX5XX/6XX/7XX

**TABLE 1-1: PINOUT I/O DESCRIPTIONS (CONTINUED)**

Pin Name	Pin Number <sup>(1)</sup>			Pin Type	Buffer Type	Description
	64-Pin QFN/TQFP	100-Pin TQFP	121-Pin XBGA			
CVREF-	15	28	L2	I	Analog	Comparator Voltage Reference (low).
CVREF+	16	29	K3	I	Analog	Comparator Voltage Reference (high).
CVREFOUT	23	34	L5	O	Analog	Comparator Voltage Reference output.
C1IN-	12	21	H2	I	Analog	Comparator 1 negative input.
C1IN+	11	20	H1	I	Analog	Comparator 1 positive input.
C1OUT	21	32	K4	O	—	Comparator 1 output.
C2IN-	14	23	J2	I	Analog	Comparator 2 negative input.
C2IN+	13	22	J1	I	Analog	Comparator 2 positive input.
C2OUT	22	33	L4	O	—	Comparator 2 output.
PMA0	—	44	L8	I/O	TTL/ST	Parallel Master Port Address Bit 0 input (Buffered Slave modes) and output (Master modes).
PMA1	—	43	K7	I/O	TTL/ST	Parallel Master Port Address Bit 1 input (Buffered Slave modes) and output (Master modes).
PMA2	8	14	F3	O	—	Parallel Master Port address (Demultiplexed Master modes).
PMA3	6	12	F2	O	—	
PMA4	5	11	F4	O	—	
PMA5	4	10	E3	O	—	
PMA6	16	29	K3	O	—	
PMA7	22	28	L2	O	—	
PMA8	32	50	L11	O	—	
PMA9	31	49	L10	O	—	
PMA10	28	42	L7	O	—	
PMA11	27	41	J7	O	—	
PMA12	24	35	J5	O	—	
PMA13	23	34	L5	O	—	
PMA14	45	71	C11	O	—	
PMA15	44	70	D11	O	—	
PMCS1	45	71	C11	O	—	
PMCS2	44	70	D11	O	—	Parallel Master Port Chip Select 2 strobe.

**Legend:** CMOS = CMOS compatible input or output      Analog = Analog input      P = Power  
 ST = Schmitt Trigger input with CMOS levels      O = Output      I = Input  
 TTL = TTL input buffer

- Note 1:** Pin numbers are provided for reference only. See the “Pin Diagrams” section for device pin availability.  
**2:** See Section 24.0 “Ethernet Controller” for more information.



# PIC32MX5XX/6XX/7XX

**TABLE 1-1: PINOUT I/O DESCRIPTIONS (CONTINUED)**

Pin Name	Pin Number <sup>(1)</sup>			Pin Type	Buffer Type	Description
	64-Pin QFN/TQFP	100-Pin TQFP	121-Pin XBGA			
PMD0	60	93	A4	I/O	TTL/ST	Parallel Master Port data (Demultiplexed Master mode) or address/data (Multiplexed Master modes).
PMD1	61	94	B4	I/O	TTL/ST	
PMD2	62	98	B3	I/O	TTL/ST	
PMD3	63	99	A2	I/O	TTL/ST	
PMD4	64	100	A1	I/O	TTL/ST	
PMD5	1	3	D3	I/O	TTL/ST	
PMD6	2	4	C1	I/O	TTL/ST	
PMD7	3	5	D2	I/O	TTL/ST	
PMD8	—	90	A5	I/O	TTL/ST	
PMD9	—	89	E6	I/O	TTL/ST	
PMD10	—	88	A6	I/O	TTL/ST	
PMD11	—	87	B6	I/O	TTL/ST	
PMD12	—	79	A9	I/O	TTL/ST	
PMD13	—	80	D8	I/O	TTL/ST	
PMD14	—	83	D7	I/O	TTL/ST	
PMD15	—	84	C7	I/O	TTL/ST	
PMALL	30	44	L8	O	—	Parallel Master Port address latch enable low byte (Multiplexed Master modes).
PMALH	29	43	K7	O	—	Parallel Master Port address latch enable high byte (Multiplexed Master modes).
PMRD	53	82	B8	O	—	Parallel Master Port read strobe.
PMWR	52	81	C8	O	—	Parallel Master Port write strobe.
VBUS	34	54	H8	I	Analog	USB bus power monitor.
VUSB	35	55	H9	P	—	USB internal transceiver supply.
VBUSON	11	20	H1	O	—	USB Host and OTG bus power control output.
D+	37	57	H10	I/O	Analog	USB D+.
D-	36	56	J11	I/O	Analog	USB D-.
USBID	33	51	K10	I	ST	USB OTG ID detect.
C1RX	58	87	B6	I	ST	CAN1 bus receive pin.
C1TX	59	88	A6	O	—	CAN1 bus transmit pin.
AC1RX	32	40	K6	I	ST	Alternate CAN1 bus receive pin.
AC1TX	31	39	L6	O	—	Alternate CAN1 bus transmit pin.
C2RX	29	90	A5	I	ST	CAN2 bus receive pin.
C2TX	21	89	E6	O	—	CAN2 bus transmit pin.
AC2RX	—	8	E2	I	ST	Alternate CAN2 bus receive pin.
AC2TX	—	7	E4	O	—	Alternate CAN2 bus transmit pin.
ERXD0	61	41	J7	I	ST	Ethernet Receive Data 0. <sup>(2)</sup>
ERXD1	60	42	L7	I	ST	Ethernet Receive Data 1. <sup>(2)</sup>
ERXD2	59	43	K7	I	ST	Ethernet Receive Data 2. <sup>(2)</sup>

**Legend:** CMOS = CMOS compatible input or output      Analog = Analog input      P = Power  
 ST = Schmitt Trigger input with CMOS levels      O = Output      I = Input  
 TTL = TTL input buffer

**Note 1:** Pin numbers are provided for reference only. See the “Pin Diagrams” section for device pin availability.  
**Note 2:** See Section 24.0 “Ethernet Controller” for more information.

# PIC32MX5XX/6XX/7XX

**TABLE 1-1: PINOUT I/O DESCRIPTIONS (CONTINUED)**

Pin Name	Pin Number <sup>(1)</sup>			Pin Type	Buffer Type	Description
	64-Pin QFN/TQFP	100-Pin TQFP	121-Pin XBGA			
ERXD3	58	44	L8	I	ST	Ethernet Receive Data 3. <sup>(2)</sup>
ERXERR	64	35	J5	I	ST	Ethernet receive error input. <sup>(2)</sup>
ERXDV	62	12	F2	I	ST	Ethernet receive data valid. <sup>(2)</sup>
ECRS DV	61	12	F2	I	ST	Ethernet carrier sense data valid. <sup>(2)</sup>
ERXCLK	63	14	F3	I	ST	Ethernet receive clock. <sup>(2)</sup>
EREFCLK	63	14	F3	I	ST	Ethernet reference clock. <sup>(2)</sup>
ETXD0	2	88	A6	O	—	Ethernet Transmit Data 0. <sup>(2)</sup>
ETXD1	3	87	B6	O	—	Ethernet Transmit Data 1. <sup>(2)</sup>
ETXD2	43	79	A9	O	—	Ethernet Transmit Data 2. <sup>(2)</sup>
ETXD3	42	80	D8	O	—	Ethernet Transmit Data 3. <sup>(2)</sup>
ETXERR	54	89	E6	O	—	Ethernet transmit error. <sup>(2)</sup>
ETXEN	1	83	D7	O	—	Ethernet transmit enable. <sup>(2)</sup>
ETXCLK	55	84	C7	I	ST	Ethernet transmit clock. <sup>(2)</sup>
ECOL	44	10	E3	I	ST	Ethernet collision detect. <sup>(2)</sup>
ECRS	45	11	F4	I	ST	Ethernet carrier sense. <sup>(2)</sup>
EMDC	30	71	C11	O	—	Ethernet management data clock. <sup>(2)</sup>
EMDIO	49	68	E9	I/O	—	Ethernet management data. <sup>(2)</sup>
AERXD0	43	18	G1	I	ST	Alternate Ethernet Receive Data 0. <sup>(2)</sup>
AERXD1	42	19	G2	I	ST	Alternate Ethernet Receive Data 1. <sup>(2)</sup>
AERXD2	—	28	L2	I	ST	Alternate Ethernet Receive Data 2. <sup>(2)</sup>
AERXD3	—	29	K3	I	ST	Alternate Ethernet Receive Data 3. <sup>(2)</sup>
AERXERR	55	1	B2	I	ST	Alternate Ethernet receive error input. <sup>(2)</sup>
AERXDV	—	12	F2	I	ST	Alternate Ethernet receive data valid. <sup>(2)</sup>
AECRS DV	44	12	F2	I	ST	Alternate Ethernet carrier sense data valid. <sup>(2)</sup>
AERXCLK	—	14	F3	I	ST	Alternate Ethernet receive clock. <sup>(2)</sup>
AEREFCLK	45	14	F3	I	ST	Alternate Ethernet reference clock. <sup>(2)</sup>
AETXD0	59	47	L9	O	—	Alternate Ethernet Transmit Data 0. <sup>(2)</sup>
AETXD1	58	48	K9	O	—	Alternate Ethernet Transmit Data 1. <sup>(2)</sup>
AETXD2	—	44	L8	O	—	Alternate Ethernet Transmit Data 2. <sup>(2)</sup>
AETXD3	—	43	K7	O	—	Alternate Ethernet Transmit Data 3. <sup>(2)</sup>
AETXERR	—	35	J5	O	—	Alternate Ethernet transmit error. <sup>(2)</sup>
AETXEN	54	67	E8	O	—	Alternate Ethernet transmit enable. <sup>(2)</sup>
AETXCLK	—	66	E11	I	ST	Alternate Ethernet transmit clock. <sup>(2)</sup>
AECOL	—	42	L7	I	ST	Alternate Ethernet collision detect. <sup>(2)</sup>
AECRS	—	41	J7	I	ST	Alternate Ethernet carrier sense. <sup>(2)</sup>
AEMDIO	49	68	E9	I/O	—	Alternate Ethernet Management Data. <sup>(2)</sup>
TRCLK	—	91	C5	O	—	Trace clock.

**Legend:** CMOS = CMOS compatible input or output      Analog = Analog input      P = Power  
 ST = Schmitt Trigger input with CMOS levels      O = Output      I = Input  
 TTL = TTL input buffer

**Note 1:** Pin numbers are provided for reference only. See the “Pin Diagrams” section for device pin availability.  
**2:** See Section 24.0 “Ethernet Controller” for more information.

# PIC32MX5XX/6XX/7XX

**TABLE 1-1: PINOUT I/O DESCRIPTIONS (CONTINUED)**

Pin Name	Pin Number <sup>(1)</sup>			Pin Type	Buffer Type	Description
	64-Pin QFN/TQFP	100-Pin TQFP	121-Pin XBGA			
TRD0	—	97	A3	O	—	Trace Data Bits 0-3.
TRD1	—	96	C3	O	—	
TRD2	—	95	C4	O	—	
TRD3	—	92	B5	O	—	
PGED1	16	25	K2	I/O	ST	Data I/O pin for Programming/Debugging Communication Channel 1.
PGEC1	15	24	K1	I	ST	Clock input pin for Programming/Debugging Communication Channel 1.
PGED2	18	27	J3	I/O	ST	Data I/O pin for Programming/Debugging Communication Channel 2.
PGEC2	17	26	L1	I	ST	Clock input pin for Programming/Debugging Communication Channel 2.
MCLR	7	13	F1	I/P	ST	Master Clear (Reset) input. This pin is an active-low Reset to the device.
AVDD	19	30	J4	P	P	Positive supply for analog modules. This pin must be connected at all times.
AVSS	20	31	L3	P	P	Ground reference for analog modules.
VDD	10, 26, 38, 57	2, 16, 37, 46, 62, 86	A7, C2, C9, E5, K8, F8, G5, H4, H6	P	—	Positive supply for peripheral logic and I/O pins.
VCAP/ VDDCORE	56	85	B7	P	—	CPU logic filter capacitor connection.
VSS	9, 25, 41	15, 36, 45, 65, 75	A8, B10, D4, D5, E7, F5, F10, G6, G7, H3	P	—	Ground reference for logic and I/O pins. This pin must be connected at all times.
VREF+	16	29	K3	I	Analog	Analog voltage reference (high) input.
VREF-	15	28	L2	I	Analog	Analog voltage reference (low) input.

**Legend:** CMOS = CMOS compatible input or output      Analog = Analog input      P = Power  
ST = Schmitt Trigger input with CMOS levels      O = Output      I = Input  
TTL = TTL input buffer

- Note 1:** Pin numbers are provided for reference only. See the “Pin Diagrams” section for device pin availability.  
**2:** See Section 24.0 “Ethernet Controller” for more information.

# PIC32MX5XX/6XX/7XX

---

NOTES:

## 2.0 GUIDELINES FOR GETTING STARTED WITH 32-BIT MICROCONTROLLERS

**Note 1:** This data sheet summarizes the features of the PIC32MX5XX/6XX/7XX family of devices. It is not intended to be a comprehensive reference source. To complement the information in this data sheet, refer to the related section of the “PIC32MX Family Reference Manual”, which is available from the Microchip web site ([www.microchip.com/PIC32](http://www.microchip.com/PIC32))

**2:** Some registers and associated bits described in this section may not be available on all devices. Refer to **Section 4.0 “Memory Organization”** in this data sheet for device-specific register and bit information.

### 2.1 Basic Connection Requirements

Getting started with the PIC32MX5XX/6XX/7XX family of 32-bit Microcontrollers (MCUs) requires attention to a minimal set of device pin connections before proceeding with development. The following is a list of pin names, which must always be connected:

- All VDD and VSS pins  
(see **Section 2.2 “Decoupling Capacitors”**)
- All AVDD and AVSS pins—even if the ADC module is not used  
(see **Section 2.2 “Decoupling Capacitors”**)
- VCAP/VDDCORE pin  
(see **Section 2.3 “Capacitor on Internal Voltage Regulator (VCAP/VDDCORE)”**)
- MCLR pin  
(see **Section 2.4 “Master Clear (MCLR) Pin”**)
- PGECx/PGEDx pins—used for In-Circuit Serial Programming (ICSP™) and debugging purposes  
(see **Section 2.5 “ICSP Pins”**)
- OSC1 and OSC2 pins—when external oscillator source is used  
(see **Section 2.8 “External Oscillator Pins”**)

The following pin may be required, as well:

VREF+/VREF- pins – used when external voltage reference for ADC module is implemented

**Note:** The AVDD and AVSS pins must be connected, regardless of ADC use and the ADC voltage reference source.

### 2.2 Decoupling Capacitors

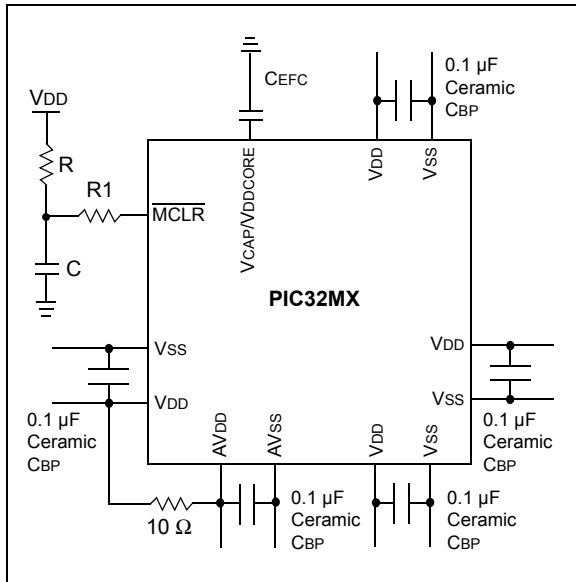
The use of decoupling capacitors on power supply pins, such as VDD, VSS, AVDD and AVSS is required. See Figure 2-1.

Consider the following criteria when using decoupling capacitors:

- **Value and type of capacitor:** A value of 0.1  $\mu\text{F}$  (100 nF), 10-20V is recommended. The capacitor should be a low Equivalent Series Resistance (low-ESR) capacitor and have resonance frequency in the range of 20 MHz and higher. It is further recommended that ceramic capacitors be used.
- **Placement on the printed circuit board:** The decoupling capacitors should be placed as close to the pins as possible. It is recommended that the capacitors be placed on the same side of the board as the device. If space is constricted, the capacitor can be placed on another layer on the PCB using a via; however, ensure that the trace length from the pin to the capacitor is within one-quarter inch (6 mm) in length.
- **Handling high frequency noise:** If the board is experiencing high frequency noise, upward of tens of MHz, add a second ceramic-type capacitor in parallel to the above described decoupling capacitor. The value of the second capacitor can be in the range of 0.01  $\mu\text{F}$  to 0.001  $\mu\text{F}$ . Place this second capacitor next to the primary decoupling capacitor. In high-speed circuit designs, consider implementing a decade pair of capacitances as close to the power and ground pins as possible. For example, 0.1  $\mu\text{F}$  in parallel with 0.001  $\mu\text{F}$ .
- **Maximizing performance:** On the board layout from the power supply circuit, run the power and return traces to the decoupling capacitors first, and then to the device pins. This ensures that the decoupling capacitors are first in the power chain. Equally important is to keep the trace length between the capacitor and the power pins to a minimum thereby reducing PCB track inductance.

# PIC32MX5XX/6XX/7XX

**FIGURE 2-1: RECOMMENDED MINIMUM CONNECTION**



## 2.2.1 BULK CAPACITORS

The use of a bulk capacitor is recommended to improve power supply stability. Typical values range from 4.7 µF to 47 µF. This capacitor should be located as close to the device as possible.

## 2.3 Capacitor on Internal Voltage Regulator (VCAP/VDDCORE)

### 2.3.1 INTERNAL REGULATOR MODE

A low-ESR (1 ohm) capacitor is required on the VCAP/VDDCORE pin, which is used to stabilize the internal voltage regulator output. The VCAP/VDDCORE pin must not be connected to VDD, and must have a CEFC capacitor, with at least a 6V rating, connected to ground. The type can be ceramic or tantalum. Refer to **Section 31.0 “Electrical Characteristics”** for additional information on CEFC specifications.

## 2.4 Master Clear (MCLR) Pin

The MCLR pin provides for two specific device functions:

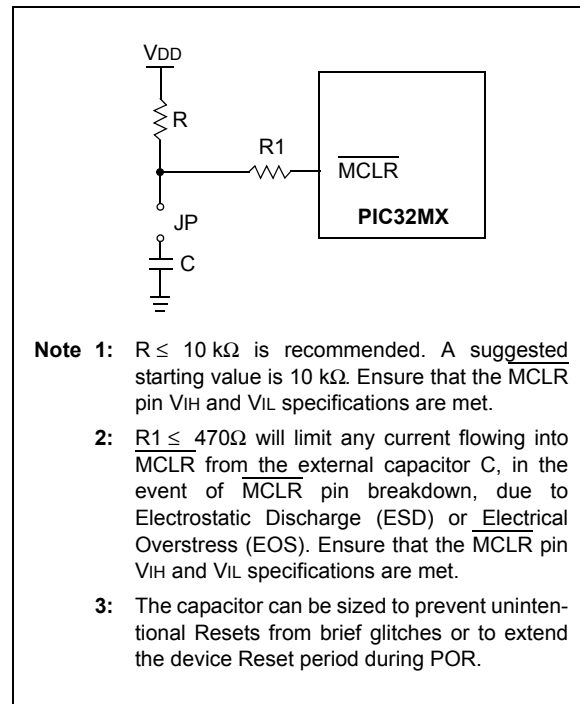
- Device Reset
- Device programming and debugging

Pulling The MCLR pin low generates a device Reset. Figure 2-2 illustrates a typical MCLR circuit. During device programming and debugging, the resistance and capacitance that can be added to the pin must be considered. Device programmers and debuggers drive the MCLR pin. Consequently, specific voltage levels ( $V_{IH}$  and  $V_{IL}$ ) and fast signal transitions must not be adversely affected. Therefore, specific values of R and C will need to be adjusted based on the application and PCB requirements.

For example, as illustrated in Figure 2-2, it is recommended that the capacitor C, be isolated from the MCLR pin during programming and debugging operations.

Place the components illustrated in Figure 2-2 within one-quarter inch (6 mm) from the MCLR pin.

**FIGURE 2-2: EXAMPLE OF MCLR PIN CONNECTIONS**



## 2.5 ICSP Pins

The PGECx and PGEDx pins are used for In-Circuit Serial Programming™ (ICSP™) and debugging purposes. It is recommended to keep the trace length between the ICSP connector and the ICSP pins on the device as short as possible. If the ICSP connector is expected to experience an ESD event, a series resistor is recommended, with the value in the range of a few tens of Ohms, not to exceed 100 Ohms.

Pull-up resistors, series diodes and capacitors on the PGECx and PGEDx pins are not recommended as they will interfere with the programmer/debugger communications to the device. If such discrete components are an application requirement, they should be removed from the circuit during programming and debugging. Alternatively, refer to the AC/DC characteristics and timing requirements information in the respective device Flash programming specification for information on capacitive loading limits and pin input voltage high ( $V_{IH}$ ) and input low ( $V_{IL}$ ) requirements.

Ensure that the “Communication Channel Select” (i.e., PGECx/PGEDx pins) programmed into the device matches the physical connections for the ICSP to MPLAB® ICD 2, MPLAB ICD 3 or MPLAB REAL ICE™.

For more information on ICD 2, ICD 3 and REAL ICE connection requirements, refer to the following documents that are available on the Microchip web site.

- “MPLAB® ICD 2 In-Circuit Debugger User’s Guide” DS51331
- “Using MPLAB® ICD 2” (poster) DS51265
- “MPLAB® ICD 2 Design Advisory” DS51566
- “Using MPLAB® ICD 3” (poster) DS51765
- “MPLAB® ICD 3 Design Advisory” DS51764
- “MPLAB® REAL ICE™ In-Circuit Debugger User’s Guide” DS51616
- “Using MPLAB® REAL ICE™ Emulator” (poster) DS51749

## 2.6 JTAG

The TMS, TDO, TDI and TCK pins are used for testing and debugging according to the Joint Test Action Group (JTAG) standard. It is recommended to keep the trace length between the JTAG connector and the JTAG pins on the device as short as possible. If the JTAG connector is expected to experience an ESD event, a series resistor is recommended, with the value in the range of a few tens of Ohms, not to exceed 100 Ohms.

Pull-up resistors, series diodes and capacitors on the TMS, TDO, TDI and TCK pins are not recommended as they will interfere with the programmer/debugger communications to the device. If such discrete components are an application requirement, they should be removed from the circuit during programming and debugging. Alternatively, refer to the AC/DC characteristics and timing requirements information in the respective device Flash programming specification for information on capacitive loading limits and pin input voltage high ( $V_{IH}$ ) and input low ( $V_{IL}$ ) requirements.

## 2.7 Trace

The trace pins can be connected to a hardware-trace-enabled programmer to provide a compressed real time instruction trace. When used for trace the TRD3, TRD2, TRD1, TRD0 and TRCLK pins should be dedicated for this use. The trace hardware requires a 22 Ohm series resistor between the trace pins and the trace connector.

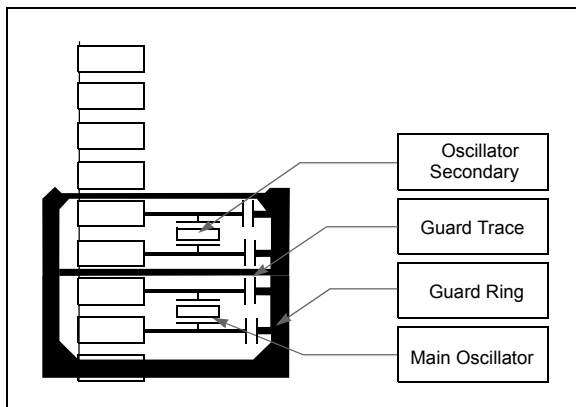
# PIC32MX5XX/6XX/7XX

## 2.8 External Oscillator Pins

Many MCUs have options for at least two oscillators: a high-frequency primary oscillator and a low-frequency secondary oscillator (refer to **Section 8.0 “Oscillator Configuration”** for details).

The oscillator circuit should be placed on the same side of the board as the device. Also, place the oscillator circuit close to the respective oscillator pins, not exceeding one-half inch (12 mm) distance between them. The load capacitors should be placed next to the oscillator itself, on the same side of the board. Use a grounded copper pour around the oscillator circuit to isolate them from surrounding circuits. The grounded copper pour should be routed directly to the MCU ground. Do not run any signal traces or power traces inside the ground pour. Also, if using a two-sided board, avoid any traces on the other side of the board where the crystal is placed. A suggested layout is illustrated in Figure 2-3.

**FIGURE 2-3: SUGGESTED OSCILLATOR CIRCUIT PLACEMENT**



## 2.9 Configuration of Analog and Digital Pins During ICSP Operations

If MPLAB ICD 2, ICD 3 or REAL ICE is selected as a debugger, it automatically initializes all of the A/D input pins (ANx) as “digital” pins by setting all bits in the ADPCFG register.

The bits in this register that correspond to the A/D pins that are initialized by MPLAB ICD 2, ICD 3 or REAL ICE, must not be cleared by the user application firmware; otherwise, communication errors will result between the debugger and the device.

If your application needs to use certain A/D pins as analog input pins during the debug session, the user application must clear the corresponding bits in the ADPCFG register during initialization of the ADC module.

When MPLAB ICD 2, ICD 3 or REAL ICE is used as a programmer, the user application firmware must correctly configure the ADPCFG register. Automatic initialization of this register is only done during debugger operation. Failure to correctly configure the register(s) will result in all A/D pins being recognized as analog input pins, resulting in the port value being read as a logic '0', which may affect user application functionality.

## 2.10 Unused I/Os

Unused I/O pins should not be allowed to float as inputs. They can be configured as outputs and driven to a logic-low state.

Alternatively, inputs can be reserved by connecting the pin to Vss through a 1k to 10k resistor and configuring the pin as an input.



## 3.0 PIC32MX MCU

**Note 1:** This data sheet summarizes the features of the PIC32MX5XX/6XX/7XX family of devices. It is not intended to be a comprehensive reference source. To complement the information in this data sheet, refer to **Section 2. “MCU”** (DS61113) in the *“PIC32MX Family Reference Manual”*, which is available from the Microchip web site ([www.microchip.com/PIC32](http://www.microchip.com/PIC32)). Resources for the MIPS32® M4K® Processor Core are available at <http://www.mips.com>.

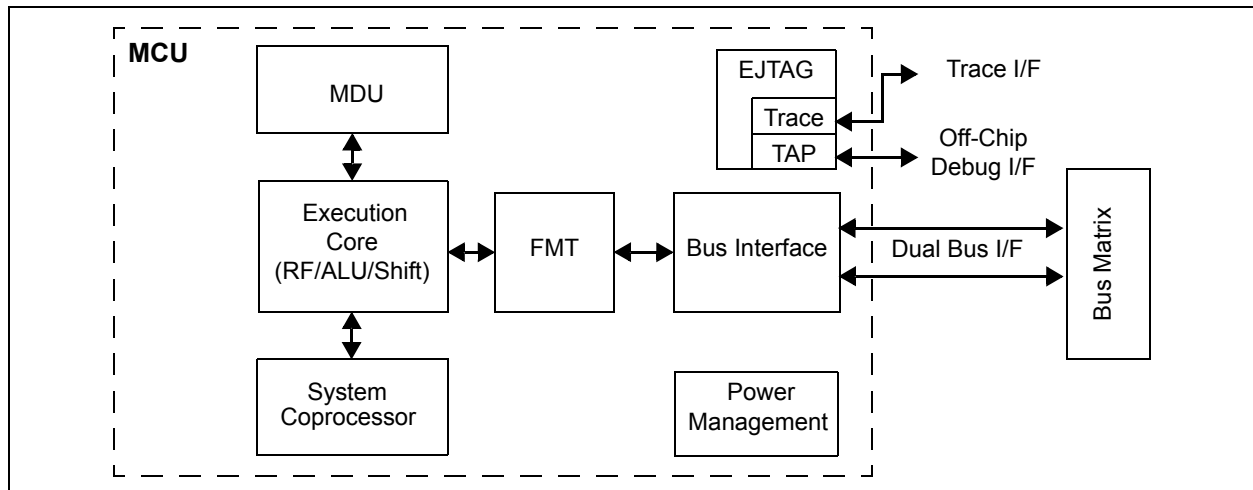
**2:** Some registers and associated bits described in this section may not be available on all devices. Refer to **Section 4.0 “Memory Organization”** in this data sheet for device-specific register and bit information.

The MCU module is the heart of the PIC32MX5XX/6XX/7XX family processor. The MCU fetches instructions, decodes each instruction, fetches source operands, executes each instruction and writes the results of instruction execution to the proper destinations.

### 3.1 Features

- 5-stage pipeline
- 32-bit address and data paths
- MIPS32 Enhanced Architecture (Release 2)
  - Multiply-accumulate and multiply-subtract instructions
  - Targeted multiply instruction
  - Zero/One detect instructions
  - WAIT instruction
  - Conditional move instructions (MOVN, MOVZ)
  - Vectored interrupts
  - Programmable exception vector base
- Atomic interrupt enable/disable
- GPR shadow registers to minimize latency for interrupt handlers
- Bit field manipulation instructions
- MIPS16e™ code compression
  - 16-bit encoding of 32-bit instructions to improve code density
  - Special PC-relative instructions for efficient loading of addresses and constants
  - SAVE and RESTORE macro instructions for setting up and tearing down stack frames within subroutines
  - Improved support for handling 8 and 16-bit data types
- Simple Mapping Translation (FMT) mechanism
- Simple dual bus interface
  - Independent 32-bit address and data busses
  - Transactions can be aborted to improve interrupt latency
- Autonomous multiply/divide unit
  - Maximum issue rate of one 32x16 multiply per clock
  - Maximum issue rate of one 32x32 multiply every other clock
  - Early-in iterative divide. Minimum 11 and maximum 33 clock latency (dividend (rs) sign extension-dependent)
- Power control
  - Minimum frequency: 0 MHz
  - Low-Power mode (triggered by WAIT instruction)
  - Extensive use of local gated clocks
- EJTAG debug and instruction trace
  - Support for single stepping
  - Virtual instruction and data address/value
  - Breakpoints
  - PC tracing with trace compression

**FIGURE 3-1: MCU BLOCK DIAGRAM**



# PIC32MX5XX/6XX/7XX

---

## 3.2 Architecture Overview

The PIC32MX5XX/6XX/7XX family core contains several logic blocks working together in parallel, providing an efficient high-performance computing engine. The following blocks are included with the core:

- Execution Unit
- Multiply/Divide Unit (MDU)
- System Control Coprocessor (CP0)
- Fixed Mapping Translation (FMT)
- Dual Internal Bus interfaces
- Power Management
- MIPS16e Support
- Enhanced JTAG (EJTAG) Controller

### 3.2.1 EXECUTION UNIT

The PIC32MX5XX/6XX/7XX family core execution unit implements a load/store architecture with single-cycle ALU operations (logical, shift, add, subtract) and an autonomous multiply/divide unit. The core contains thirty-two 32-bit General Purpose Registers (GPRs) used for integer operations and address calculation. One additional register file shadow set (containing thirty-two registers) is added to minimize context switching overhead during interrupt/exception processing. The register file consists of two read ports and one write port and is fully bypassed to minimize operation latency in the pipeline.

The execution unit includes:

- 32-bit adder used for calculating the data address
- Address unit for calculating the next instruction address
- Logic for branch determination and branch target address calculation
- Load aligner
- Bypass multiplexers used to avoid stalls when executing instruction streams where data producing instructions are followed closely by consumers of their results
- Leading Zero/One detect unit for implementing the `CLZ` and `CLO` instructions
- Arithmetic Logic Unit (ALU) for performing bitwise logical operations
- Shifter and store aligner

### 3.2.2 MULTIPLY/DIVIDE UNIT (MDU)

The PIC32MX5XX/6XX/7XX family core includes a Multiply/Divide Unit (MDU) that contains a separate pipeline for multiply and divide operations. This pipeline operates in parallel with the Integer Unit (IU) pipeline and does not stall when the IU pipeline stalls. This allows MDU operations to be partially masked by system stalls and/or other integer unit instructions.

The high-performance MDU consists of a 32x16 booth recoded multiplier, result/accumulation registers (HI and LO), a divide state machine, and the necessary multiplexers and control logic. The first number shown ('32' of 32x16) represents the *rs* operand. The second number ('16' of 32x16) represents the *rt* operand. The PIC32MX core only checks the value of the latter (*rt*) operand to determine how many times the operation must pass through the multiplier. The 16x16 and 32x16 operations pass through the multiplier once. A 32x32 operation passes through the multiplier twice.

The MDU supports execution of one 16x16 or 32x16 multiply operation every clock cycle; 32x32 multiply operations can be issued every other clock cycle. Appropriate interlocks are implemented to stall the issuance of back-to-back 32x32 multiply operations. The multiply operand size is automatically determined by logic built into the MDU.

Divide operations are implemented with a simple 1 bit per clock iterative algorithm. An early-in detection checks the sign extension of the dividend (*rs*) operand. If *rs* is 8 bits wide, 23 iterations are skipped. For a 16-bit wide *rs*, 15 iterations are skipped and for a 24-bit wide *rs*, 7 iterations are skipped. Any attempt to issue a subsequent MDU instruction while a divide is still active causes an IU pipeline stall until the divide operation is completed.

Table 3-1 lists the repeat rate (peak issue rate of cycles until the operation can be reissued) and latency (number of cycles until a result is available) for the PIC32MX core multiply and divide instructions. The approximate latency and repeat rates are listed in terms of pipeline clocks.

**TABLE 3-1: PIC32MX5XX/6XX/7XX FAMILY CORE HIGH-PERFORMANCE INTEGER MULTIPLY/DIVIDE UNIT LATENCIES AND REPEAT RATES**

Opcode	Operand Size (mul <i>rt</i> ) (div <i>rs</i> )	Latency	Repeat Rate
MULT/MULTU, MADD/MADDU, MSUB/MSUBU	16 bits	1	1
	32 bits	2	2
MUL	16 bits	2	1
	32 bits	3	2
DIV/DIVU	8 bits	12	11
	16 bits	19	18
	24 bits	26	25
	32 bits	33	32

The MIPS architecture defines that the result of a multiply or divide operation be placed in the HI and LO registers. Using the Move-From-HI (MFHI) and Move-From-LO (MFLO) instructions, these values can be transferred to the General Purpose Register file.

In addition to the HI/LO targeted operations, the MIPS32 architecture also defines a multiply instruction, MUL, which places the least significant results in the primary register file instead of the HI/LO register pair. By avoiding the explicit MFLO instruction required when using the LO register, and by supporting multiple destination registers, the throughput of multiply-intensive operations is increased.

Two other instructions, Multiply-Add (MADD) and Multiply-Subtract (MSUB), are used to perform the multiply-accumulate and multiply-subtract operations. The MADD instruction multiplies two numbers and then adds the product to the current contents of the HI and LO registers. Similarly, the MSUB instruction multiplies two operands and then subtracts the product from the HI and LO registers. The MADD and MSUB operations are commonly used in DSP algorithms.

### 3.2.3 SYSTEM CONTROL COPROCESSOR (CP0)

In the MIPS architecture, CP0 is responsible for the virtual-to-physical address translation, the exception control system, the processor's diagnostics capability, the operating modes (Kernel, User and Debug) and whether interrupts are enabled or disabled. Configuration information, such as presence of options like MIPS16e, is also available by accessing the CP0 registers, listed in Table 3-2.

# PIC32MX5XX/6XX/7XX

TABLE 3-2: COPROCESSOR 0 REGISTERS

Register Number	Register Name	Function
0-6	Reserved	Reserved in the PIC32MX5XX/6XX/7XX family core.
7	HWREna	Enables access via the RDHWR instruction to selected hardware registers.
8	BadVAddr <sup>(1)</sup>	Reports the address for the most recent address-related exception.
9	Count <sup>(1)</sup>	Processor cycle count.
10	Reserved	Reserved in the PIC32MX5XX/6XX/7XX family core.
11	Compare <sup>(1)</sup>	Timer interrupt control.
12	Status <sup>(1)</sup>	Processor status and control.
12	IntCtl <sup>(1)</sup>	Interrupt system status and control.
12	SRSCtl <sup>(1)</sup>	Shadow register set status and control.
12	SRSMap <sup>(1)</sup>	Provides mapping from vectored interrupt to a shadow set.
13	Cause <sup>(1)</sup>	Cause of last general exception.
14	EPC <sup>(1)</sup>	Program counter at last exception.
15	PRId	Processor identification and revision.
15	EBASE	Exception vector base register.
16	Config	Configuration register.
16	Config1	Configuration Register 1.
16	Config2	Configuration Register 2.
16	Config3	Configuration Register 3.
17-22	Reserved	Reserved in the PIC32MX5XX/6XX/7XX family core.
23	Debug <sup>(2)</sup>	Debug control and exception status.
24	DEPC <sup>(2)</sup>	Program counter at last debug exception.
25-29	Reserved	Reserved in the PIC32MX5XX/6XX/7XX family core.
30	ErrorEPC <sup>(1)</sup>	Program counter at last error.
31	DESAVE <sup>(2)</sup>	Debug handler scratchpad register.

**Note 1:** Registers used in exception processing.

**2:** Registers used during debug.

Coprocessor 0 also contains the logic for identifying and managing exceptions. Exceptions can be caused by a variety of sources, including alignment errors in data, external events or program errors. Table 3-3 lists the exception types in order of priority.

**TABLE 3-3: PIC32MX5XX/6XX/7XX FAMILY CORE EXCEPTION TYPES**

Exception	Description
Reset	Assertion $\overline{\text{MCLR}}$ or a Power-on Reset (POR).
DSS	EJTAG debug single step.
DINT	EJTAG debug interrupt. Caused by the assertion of the external <i>EJ_DINT</i> input or by setting the <i>EjtagBrk</i> bit in the ECR register.
NMI	Assertion of NMI signal.
Interrupt	Assertion of unmasked hardware or software interrupt signal.
DIB	EJTAG debug hardware instruction break matched.
AdEL	Fetch address alignment error. Fetch reference to protected address.
IBE	Instruction fetch bus error.
DBp	EJTAG breakpoint (execution of <i>SDBBP</i> instruction).
Sys	Execution of <i>SYSCALL</i> instruction.
Bp	Execution of <i>BREAK</i> instruction.
RI	Execution of a reserved instruction.
CpU	Execution of a coprocessor instruction for a coprocessor that is not enabled.
CEU	Execution of a <i>CorExtend</i> instruction when <i>CorExtend</i> is not enabled.
Ov	Execution of an arithmetic instruction that overflowed.
Tr	Execution of a trap (when trap condition is true).
DDBL/DDBS	EJTAG Data Address Break (address only) or EJTAG data value break on store (address + value).
AdEL	Load address alignment error. Load reference to protected address.
AdES	Store address alignment error. Store to protected address.
DBE	Load or store bus error.
DDBL	EJTAG data hardware breakpoint matched in load data compare.

# PIC32MX5XX/6XX/7XX

---

## 3.3 Power Management

The PIC32MX5XX/6XX/7XX family core offers a number of power management features, including low-power design, active power management and power-down modes of operation. The core is a static design that supports slowing or Halting the clocks, which reduces system power consumption during Idle periods.

### 3.3.1 INSTRUCTION-CONTROLLED POWER MANAGEMENT

The mechanism for invoking Power-Down mode is through execution of the `WAIT` instruction. For more information on power management, see **Section 27.0 “Power-Saving Features”**.

### 3.3.2 LOCAL CLOCK GATING

The majority of the power consumed by the PIC32MX5XX/6XX/7XX family core is in the clock tree and clocking registers. The PIC32MX family uses extensive use of local gated clocks to reduce this dynamic power consumption.

## 3.4 EJTAG Debug Support

The PIC32MX5XX/6XX/7XX family core provides for an Enhanced JTAG (EJTAG) interface for use in the software debug of application and kernel code. In addition to standard User mode and Kernel modes of operation, the PIC32MX5XX/6XX/7XX family core provides a Debug mode that is entered after a debug exception (derived from a hardware breakpoint, single-step exception, etc.) is taken and continues until a Debug Exception Return (`DERET`) instruction is executed. During this time, the processor executes the debug exception handler routine.

The EJTAG interface operates through the Test Access Port (TAP), a serial communication port used for transferring test data in and out of the PIC32MX5XX/6XX/7XX family core. In addition to the standard JTAG instructions, special instructions defined in the EJTAG specification define which registers are selected and how they are used.

## 4.0 MEMORY ORGANIZATION

**Note:** This data sheet summarizes the features of the PIC32MX5XX/6XX/7XX family of devices. It is not intended to be a comprehensive reference source. For detailed information, refer to **Section 3. “Memory Organization”** (DS61115) in the *“PIC32MX Family Reference Manual”*, which is available from the Microchip web site ([www.microchip.com/PIC32](http://www.microchip.com/PIC32)).

PIC32MX5XX/6XX/7XX microcontrollers provide 4 GB of unified virtual memory address space. All memory regions, including program, data memory, SFRs and Configuration registers, reside in this address space at their respective unique addresses. The program and data memories can be optionally partitioned into user and kernel memories. In addition, the data memory can be made executable, allowing PIC32MX5XX/6XX/7XX devices to execute from data memory.

Key features include:

- 32-bit native data width
- Separate User (KUSEG) and Kernel (KSEG0/KSEG1) mode address space
- Flexible program Flash memory partitioning
- Flexible data RAM partitioning for data and program space
- Separate boot Flash memory for protected code
- Robust bus exception handling to intercept runaway code
- Simple memory mapping with Fixed Mapping Translation (FMT) unit
- Cacheable (KSEG0) and non-cacheable (KSEG1) address regions

## 4.1 PIC32MX5XX/6XX/7XX Memory Layout

PIC32MX5XX/6XX/7XX microcontrollers implement two address schemes: virtual and physical. All hardware resources, such as program memory, data memory and peripherals, are located at their respective physical addresses. Virtual addresses are exclusively used by the CPU to fetch and execute instructions as well as access peripherals. Physical addresses are used by bus master peripherals, such as DMA and the Flash controller, that access memory independently of the CPU.

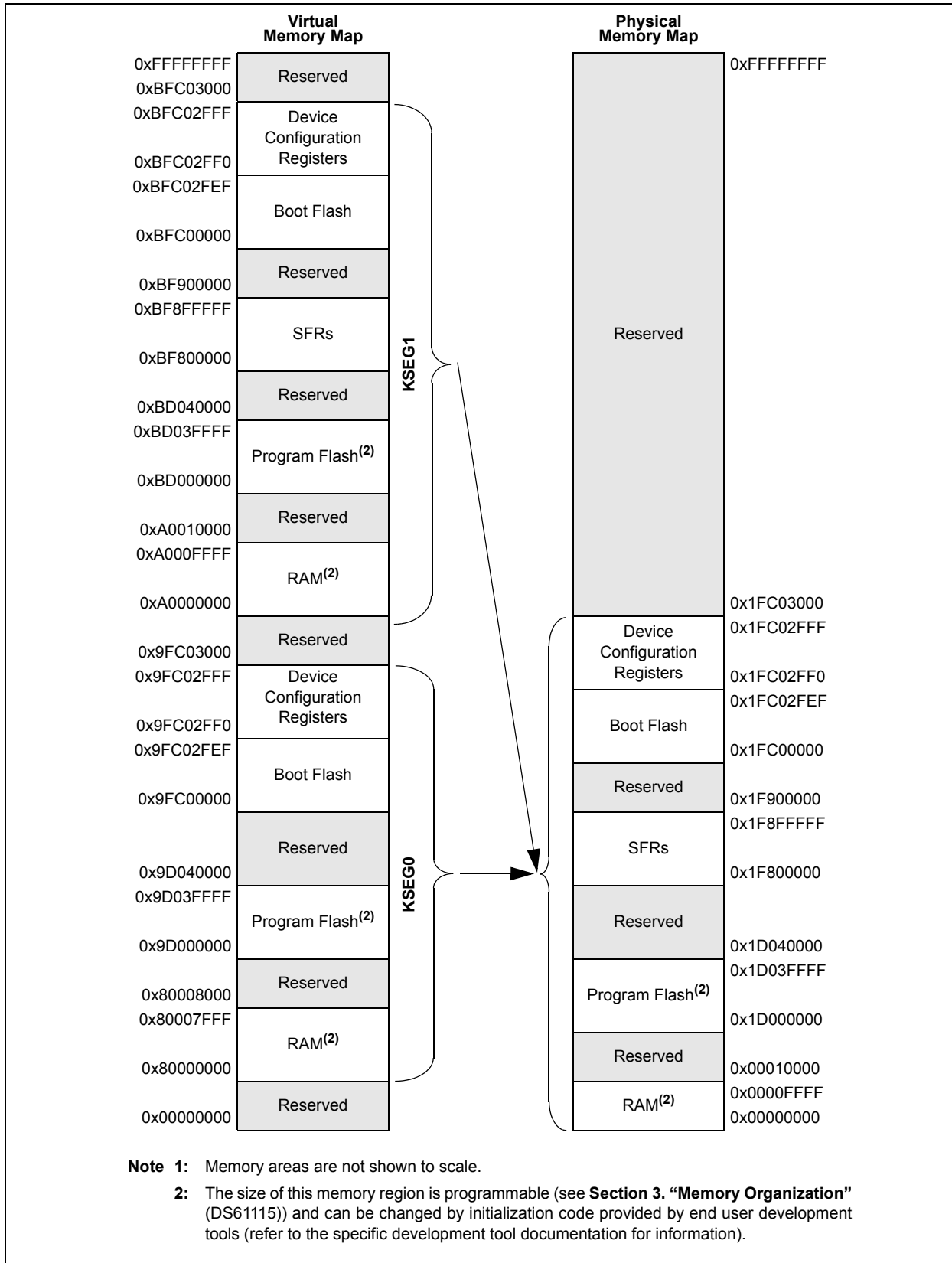
The memory maps for the PIC32MX5XX/6XX/7XX devices are illustrated in Figure 4-1 through Figure 4-3.

### 4.1.1 PERIPHERAL REGISTERS LOCATIONS

Table 4-1 through Table 4-44 contain the peripheral address maps for the PIC32MX5XX/6XX/7XX devices. Peripherals located on the PB bus are mapped to 512-byte boundaries. Peripherals on the FPB bus are mapped to 4-Kbyte boundaries.

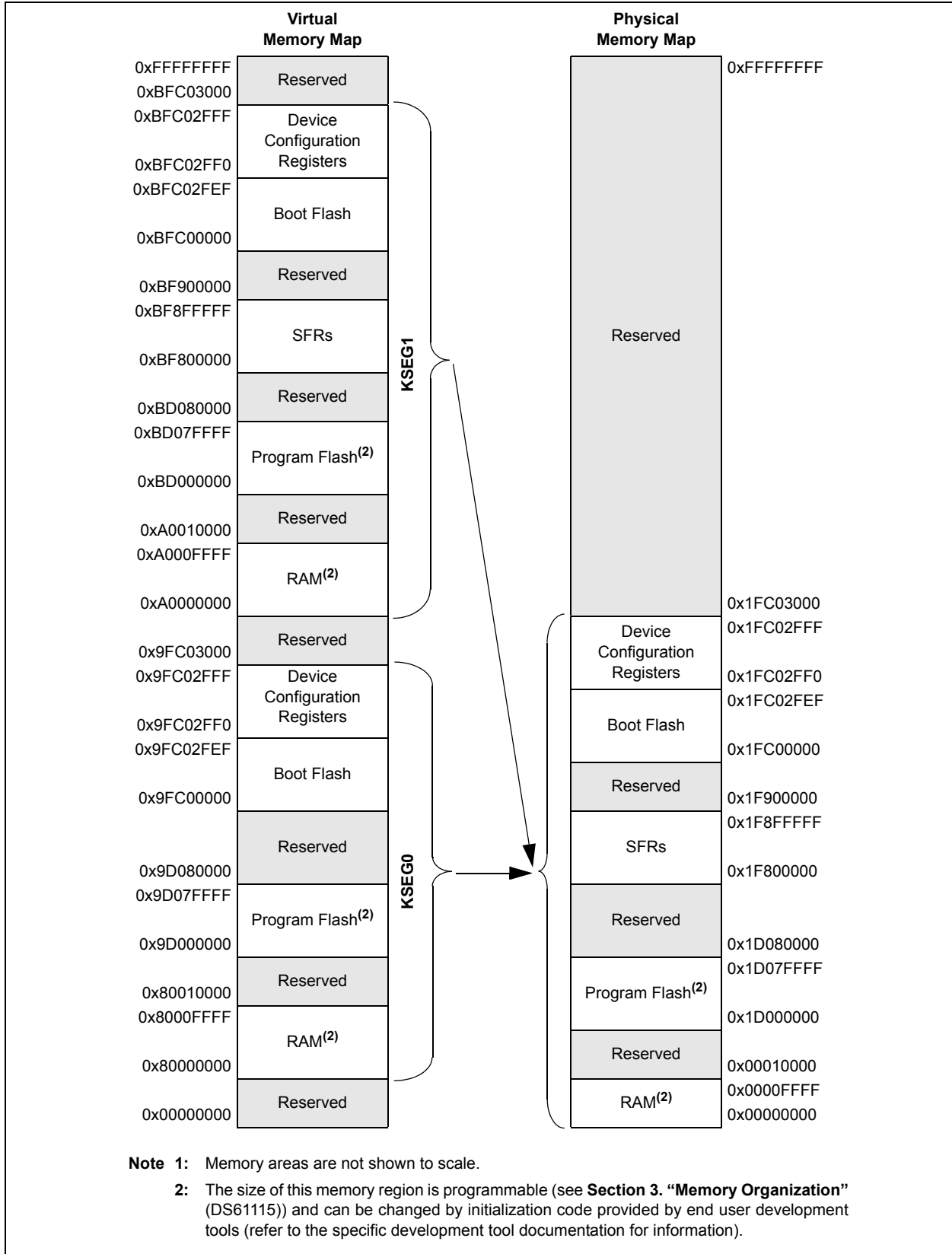
# PIC32MX5XX/6XX/7XX

**FIGURE 4-1: MEMORY MAP ON RESET FOR PIC32MX575F256H, PIC32MX575F256L, PIC32MX675F256H, PIC32MX675F256L, PIC32MX775F256H AND PIC32MX775F256L DEVICES<sup>(1)</sup>**



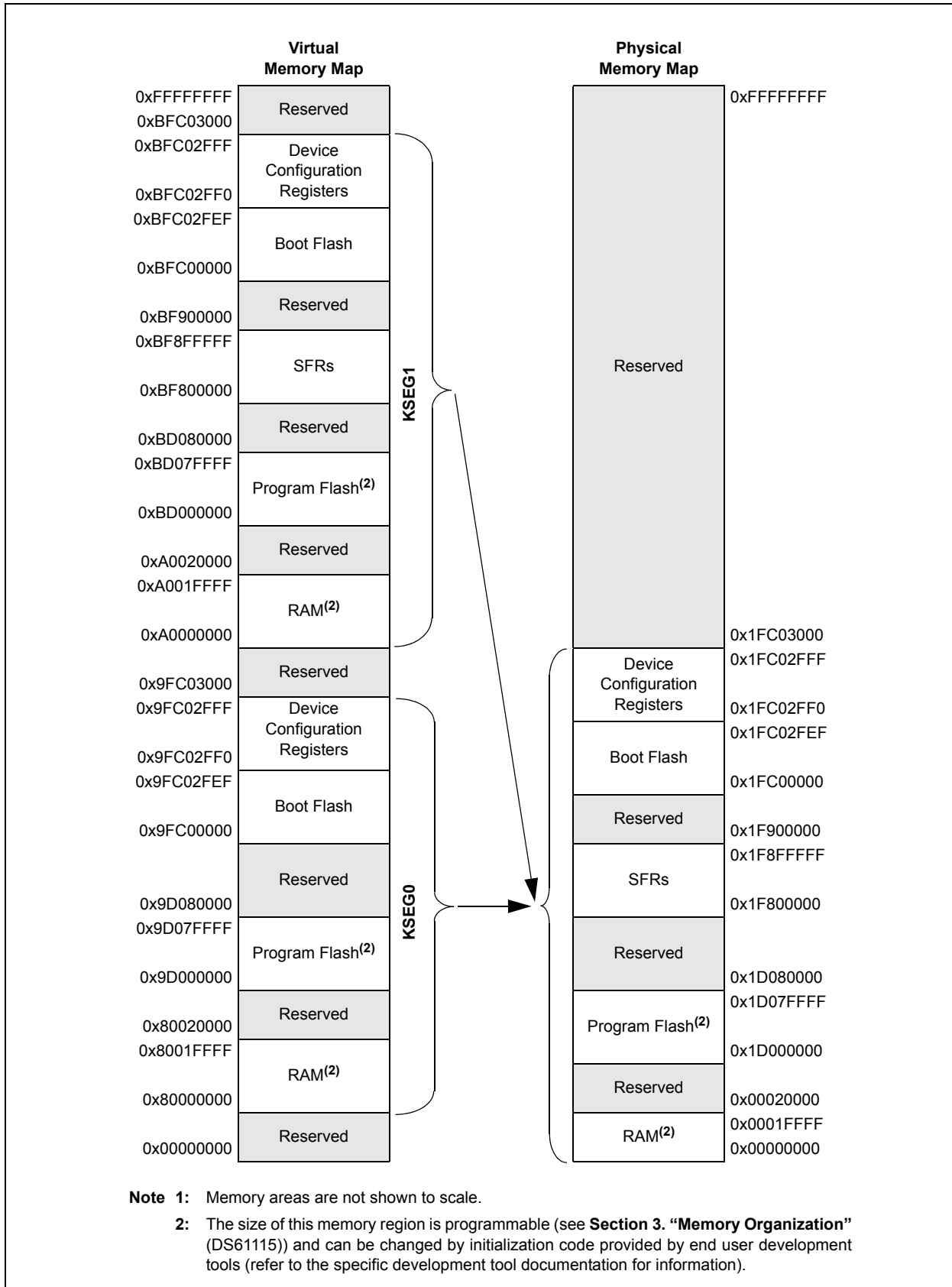


**FIGURE 4-2: MEMORY MAP ON RESET FOR PIC32MX575F512H, PIC32MX575F512L, PIC32MX675F512H, PIC32MX675F512L, PIC32MX775F512H AND PIC32MX775F512L DEVICES**



# PIC32MX5XX/6XX/7XX

**FIGURE 4-3: MEMORY MAP ON RESET FOR PIC32MX695F512H, PIC32MX695F512L, PIC32MX795F512H AND PIC32MX795F512L DEVICES**



**TABLE 4-1: BUS MATRIX REGISTER MAP**

Virtual Address (BF88_#)	Register Name	Bit Range	Bits																All Resets
			31/15	30/14	29/13	28/12	27/11	26/10	25/9	24/8	23/7	22/6	21/5	20/4	19/3	18/2	17/1	16/0	
2000	BMXCON <sup>(1)</sup>	31:16	—	—	—	—	—	BMXCHEDMA	—	—	—	—	—	BMXERRIXI	BMXERRICD	BMXERRDMA	BMXERRDS	BMXERRIS	001F
		15:0	—	—	—	—	—	—	—	—	—	BMXWSDRM	—	—	—	BMXARB<2:0>			0041
2010	BMXDKPBA <sup>(1)</sup>	31:16	—	—	—	—	—	—	—	—	—	—	—	—	—	—	—	0000	
		15:0	BMXDKPBA<15:0>																0000
2020	BMXDUDBA <sup>(1)</sup>	31:16	—	—	—	—	—	—	—	—	—	—	—	—	—	—	—	0000	
		15:0	BMXDUDBA<15:0>																0000
2030	BMXDUPBA <sup>(1)</sup>	31:16	—	—	—	—	—	—	—	—	—	—	—	—	—	—	—	0000	
		15:0	BMXDUPBA<15:0>																0000
2040	BMXDRMSZ	31:16	BMXDRMSZ<31:0>																xxxx
		15:0	BMXDRMSZ<31:0>																xxxx
2050	BMXPUPBA <sup>(1)</sup>	31:16	—	—	—	—	—	—	—	—	—	—	—	—	BMXPUPBA<19:16>			0000	
		15:0	BMXPUPBA<15:0>																0000
2060	BMXPFMSZ	31:16	BMXPFMSZ<31:0>																xxxx
		15:0	BMXPFMSZ<31:0>																xxxx
2070	BMXBOOTSZ	31:16	BMXBOOTSZ<31:0>																0000
		15:0	BMXBOOTSZ<31:0>																3000

**Legend:** x = unknown value on Reset; — = unimplemented, read as '0'. Reset values are shown in hexadecimal.

**Note 1:** This register has corresponding CLR, SET and INV registers at its virtual address, plus an offset of 0x4, 0x8 and 0xC, respectively. See **Section 12.1.1 “CLR, SET and INV Registers”** for more information.

**TABLE 4-2: INTERRUPT REGISTER MAP FOR PIC32MX575F256H AND PIC32MX575F512H DEVICES<sup>(1)</sup>**

Virtual Address (BF88_#)	Register Name	Bit Range	Bits															All Resets								
			31/15	30/14	29/13	28/12	27/11	26/10	25/9	24/8	23/7	22/6	21/5	20/4	19/3	18/2	17/1		16/0							
1000	INTCON	31:16	—	—	—	—	—	—	—	—	—	—	—	—	—	—	—	SS0	0000							
		15:0	—	FRZ	—	MVEC	—	TPC<2:0>			—	—	—	INT4EP	INT3EP	INT2EP	INT1EP	INT0EP	0000							
1010	INTSTAT	31:16	—	—	—	—	—	—	—	—	—	—	—	—	—	—	—	—	0000							
		15:0	—	—	—	—	—	RIPL<2:0>			—	—	VEC<5:0>					0000								
1020	IPTMR	31:16	IPTMR<31:0>															0000								
		15:0																0000								
1030	IFS0	31:16	I2C1MIF	I2C1SIF	I2C1BIF	U1ATXIF	U1ARXIF	U1AEIF	—	—	—	OC5IF	IC5IF	T5IF	INT4IF	OC4IF	IC4IF	T4IF	0000							
						SPI1ATXIF	SPI1ARXIF	SPI1AEIF																		
						I2C1AMIF	I2C1ASIF	I2C1ABIF																		
1040	IFS1	31:16	IC3EIF	IC2EIF	IC1EIF	—	—	CAN1IF	USBIF	FCEIF	DMA7IF	DMA6IF	DMA5IF	DMA4IF	DMA3IF	DMA2IF	DMA1IF	DMA0IF	0000							
																				U3ATXIF	U3ARXIF	U3AEIF	U2ATXIF	U2ARXIF	U2AEIF	
1050	IFS2	15:0	RTCCIF	FSCMIF	—	—	—	U3BTXIF	U3BRXIF	U3BEIF	U2BTXIF	U2BRXIF	U2BEIF	U1BTXIF	U1BRXIF	U1BEIF	PMPEIF	IC5EIF	IC4EIF	0000						
																					SPI3ATXIF	SPI3ARXIF	SPI3AEIF	SPI2ATXIF	SPI2ARXIF	SPI2AEIF
																					I2C3AMIF	I2C3ASIF	I2C3ASIF	I2C2AMIF	I2C2ASIF	I2C2ABIF
1060	IEC0	31:16	I2C1MIE	I2C1SIE	I2C1BIE	U1ATXIE	U1ARXIE	U1AEIE	—	—	—	OC5IE	IC5IE	T5IE	INT4IE	OC4IE	IC4IE	T4IE	0000							
						SPI1ATXIE	SPI1ARXIE	SPI1AEIE																		
						I2C1AMIE	I2C1ASIE	I2C1ABIE																		
1070	IEC1	15:0	RTCCIE	FSCMIE	—	—	—	U3BTXIE	U3BRXIE	U3BEIE	U2BTXIE	U2BRXIE	U2BEIE	U1BTXIE	U1BRXIE	U1BEIE	PMPEIE	IC5EIE	IC4EIE	0000						
																					SPI3ATXIE	SPI3ARXIE	SPI3AEIE	SPI2ATXIE	SPI2ARXIE	SPI2AEIE
																					I2C3AMIE	I2C3ASIE	I2C3ASIE	I2C2AMIE	I2C2ASIE	I2C2ABIE
1080	IEC2	31:16	—	—	—	—	—	—	—	—	—	—	—	—	—	—	—	—	—	0000						
		15:0	—	—	—	—	—	U3BTXIE	U3BRXIE	U3BEIE	U2BTXIE	U2BRXIE	U2BEIE	U1BTXIE	U1BRXIE	U1BEIE	PMPEIE	IC5EIE	IC4EIE	0000						
1090	IPC0	31:16	INT0IP<2:0>				INT0IS<1:0>				—	—	—	CS1IP<2:0>			CS1IS<1:0>			0000						
		15:0	CS0IP<2:0>				CS0IS<1:0>				—	—	—	CTIP<2:0>			CTIS<1:0>			0000						
10A0	IPC1	31:16	INT1IP<2:0>				INT1IS<1:0>				—	—	—	OC1IP<2:0>			OC1IS<1:0>			0000						
		15:0	IC1IP<2:0>				IC1IS<1:0>				—	—	—	T1IP<2:0>			T1IS<1:0>			0000						

**Legend:** x = unknown value on Reset; — = unimplemented, read as '0'. Reset values are shown in hexadecimal.  
**Note 1:** All registers in this table have corresponding CLR, SET and INV registers at their virtual addresses, plus offsets of 0x4 0x8 and 0xC, respectively. See Section 12.1.1 “CLR, SET and INV Registers” for more information.

**TABLE 4-2: INTERRUPT REGISTER MAP FOR PIC32MX575F256H AND PIC32MX575F512H DEVICES<sup>(1)</sup> (CONTINUED)**

Virtual Address (BF68_#)	Register Name	Bit Range	Bits														All Resets		
			31/15	30/14	29/13	28/12	27/11	26/10	25/9	24/8	23/7	22/6	21/5	20/4	19/3	18/2		17/1	16/0
10B0	IPC2	31:16	—	—	—	INT2IP<2:0>			INT2IS<1:0>			—	—	—	OC2IP<2:0>		OC2IS<1:0>		0000
		15:0	—	—	—	IC2IP<2:0>			IC2IS<1:0>			—	—	—	T2IP<2:0>		T2IS<1:0>		0000
10C0	IPC3	31:16	—	—	—	INT3IP<2:0>			INT3IS<1:0>			—	—	—	OC3IP<2:0>		OC3IS<1:0>		0000
		15:0	—	—	—	IC3IP<2:0>			IC3IS<1:0>			—	—	—	T3IP<2:0>		T3IS<1:0>		0000
10D0	IPC4	31:16	—	—	—	INT4IP<2:0>			INT4IS<1:0>			—	—	—	OC4IP<2:0>		OC4IS<1:0>		0000
		15:0	—	—	—	IC4IP<2:0>			IC4IS<1:0>			—	—	—	T4IP<2:0>		T4IS<1:0>		0000
10E0	IPC5	31:16	—	—	—	—	—	—	—	—	—	—	—	—	OC5IP<2:0>		OC5IS<1:0>		0000
		15:0	—	—	—	IC5IP<2:0>			IC5IS<1:0>			—	—	—	T5IP<2:0>		T5IS<1:0>		0000
10F0	IPC6	31:16	—	—	—	AD1IP<2:0>			AD1IS<1:0>			—	—	—	CNIP<2:0>		CNIS<1:0>		0000
		15:0	—	—	—	I2C1IP<2:0>			I2C1IS<1:0>			—	—	—	U1AIP<2:0>		U1AIS<1:0>		0000
															SPI1AIP<2:0>		SPI1AIS<1:0>		
I2C1AIP<2:0>		I2C1AIS<1:0>																	
1100	IPC7	31:16	—	—	—	U2AIP<2:0>			U2AIS<1:0>			—	—	—	CMP2IP<2:0>		CMP2IS<1:0>		0000
		SPI2AIP<2:0>			SPI2AIS<1:0>														
1110	IPC8	31:16	—	—	—	RTCCIP<2:0>			RTCCIS<1:0>			—	—	—	FSCMIP<2:0>		FSCMIS<1:0>		0000
		15:0	—	—	—	—	—	—	—	—	—	—	—	—	—	U3AIP<2:0>		U3AIS<1:0>	
SPI3AIP<2:0>		SPI3AIS<1:0>																	
I2C3AIP<2:0>		I2C3AIS<1:0>																	
1120	IPC9	31:16	—	—	—	DMA3IP<2:0>			DMA3IS<1:0>			—	—	—	DMA2IP<2:0>		DMA2IS<1:0>		0000
		15:0	—	—	—	DMA1IP<2:0>			DMA1IS<1:0>			—	—	—	DMA0IP<2:0>		DMA0IS<1:0>		0000
1130	IPC10	31:16	—	—	—	DMA7IP<2:0>			DMA7IS<1:0>			—	—	—	DMA6IP<2:0>		DMA6IS<1:0>		0000
		15:0	—	—	—	DMA5IP<2:0>			DMA5IS<1:0>			—	—	—	DMA4IP<2:0>		DMA4IS<1:0>		0000
1140	IPC11	31:16	—	—	—	—	—	—	—	—	—	—	—	—	CAN1IP<2:0>		CAN1IS<1:0>		0000
		15:0	—	—	—	USBIP<2:0>			USBIS<1:0>			—	—	—	FCEIP<2:0>		FCEIS<1:0>		0000
1150	IPC12	31:16	—	—	—	U3BIP<2:0>			U3BIS<1:0>			—	—	—	U2BIP<2:0>		U2BIS<1:0>		0000
		15:0	—	—	—	U1BIP<2:0>			U1BIS<1:0>			—	—	—	—	—	—	—	0000

**Legend:** x = unknown value on Reset; — = unimplemented, read as '0'. Reset values are shown in hexadecimal.

**Note 1:** All registers in this table have corresponding CLR, SET and INV registers at their virtual addresses, plus offsets of 0x4 0x8 and 0xC, respectively. See Section 12.1.1 "CLR, SET and INV Registers" for more information.

**TABLE 4-3: INTERRUPT REGISTER MAP FOR PIC32MX675F256H, PIC32MX675F512H AND PIC32MX695F512H DEVICES<sup>(1)</sup>**

Virtual Address (BF88_#)	Register Name	Bit Range	Bits															All Resets					
			31/15	30/14	29/13	28/12	27/11	26/10	25/9	24/8	23/7	22/6	21/5	20/4	19/3	18/2	17/1		16/0				
1000	INTCON	31:16	—	—	—	—	—	—	—	—	—	—	—	—	—	—	—	SS0	0000				
		15:0	—	FRZ	—	MVEC	—	—	—	—	—	—	—	—	—	—	—	—	INT4EP	INT3EP	INT2EP	INT1EP	INT0EP
1010	INTSTAT	31:16	—	—	—	—	—	—	—	—	—	—	—	—	—	—	—	—	—	—	—	—	0000
		15:0	—	—	—	—	—	—	—	—	—	—	—	—	—	—	—	—	—	—	—	—	—
1020	IPTMR	31:16	IPTMR<31:0>																			0000	
		15:0																				0000	
1030	IFS0	31:16	I2C1MIF	I2C1SIF	I2C1BIF	U1ATXIF	U1ARXIF	U1AEIF	—	—	—	OC5IF	IC5IF	T5IF	INT4IF	OC4IF	IC4IF	T4IF	0000				
		15:0	INT3IF	OC3IF	IC3IF	T3IF	INT2IF	OC2IF	IC2IF	T2IF	INT1IF	OC1IF	IC1IF	T1IF	INT0IF	CS1IF	CS0IF	CTIF	0000				
1040	IFS1	31:16	IC3EIF	IC2EIF	IC1EIF	ETHIF	—	—	USBIF	FCEIF	DMA7IF	DMA6IF	DMA5IF	DMA4IF	DMA3IF	DMA2IF	DMA1IF	DMA0IF	0000				
		15:0	RTCCIF	FSCMIF	—	—	—	—	—	—	—	—	—	—	—	—	—	—	—	—	—	—	0000
1050	IFS2	31:16	—	—	—	—	—	—	—	—	—	—	—	—	—	—	—	—	—	—	—	—	0000
		15:0	—	—	—	—	—	—	—	—	—	—	—	—	—	—	—	—	—	—	—	—	—
1060	IEC0	31:16	I2C1MIE	I2C1SIE	I2C1BIE	U1ATXIE	U1ARXIE	U1AEIE	—	—	—	OC5IE	IC5IE	T5IE	INT4IE	OC4IE	IC4IE	T4IE	0000				
		15:0	INT3IE	OC3IE	IC3IE	T3IE	INT2IE	OC2IE	IC2IE	T2IE	INT1IE	OC1IE	IC1IE	T1IE	INT0IE	CS1IE	CS0IE	CTIE	0000				
1070	IEC1	31:16	IC3EIE	IC2EIE	IC1EIE	ETHIE	—	—	USBIE	FCEIE	DMA7IE	DMA6IE	DMA5IE	DMA4IE	DMA3IE	DMA2IE	DMA1IE	DMA0IE	0000				
		15:0	RTCCIE	FSCMIE	—	—	—	—	—	—	—	—	—	—	—	—	—	—	—	—	—	—	0000
1080	IEC2	31:16	—	—	—	—	—	—	—	—	—	—	—	—	—	—	—	—	—	—	—	—	0000
		15:0	—	—	—	—	—	—	—	—	—	—	—	—	—	—	—	—	—	—	—	—	0000
1090	IPC0	31:16	—	—	—	—	—	—	INT0IP<2:0>	—	—	—	—	—	—	—	—	—	—	—	—	—	0000
		15:0	—	—	—	—	—	—	CS0IP<2:0>	—	—	—	—	—	—	—	—	—	—	—	—	—	0000
10A0	IPC1	31:16	—	—	—	—	—	—	INT1IP<2:0>	—	—	—	—	—	—	—	—	—	—	—	—	—	0000
		15:0	—	—	—	—	—	—	IC1IP<2:0>	—	—	—	—	—	—	—	—	—	—	—	—	—	0000
10B0	IPC2	31:16	—	—	—	—	—	—	INT2IP<2:0>	—	—	—	—	—	—	—	—	—	—	—	—	—	0000
		15:0	—	—	—	—	—	—	IC2IP<2:0>	—	—	—	—	—	—	—	—	—	—	—	—	—	0000
10C0	IPC3	31:16	—	—	—	—	—	—	INT3IP<2:0>	—	—	—	—	—	—	—	—	—	—	—	—	—	0000
		15:0	—	—	—	—	—	—	IC3IP<2:0>	—	—	—	—	—	—	—	—	—	—	—	—	—	0000

**Legend:** x = unknown value on Reset; — = unimplemented, read as '0'. Reset values are shown in hexadecimal.

**Note 1:** All registers in this table have corresponding CLR, SET and INV registers at their virtual addresses, plus offsets of 0x4, 0x8 and 0xC respectively. See Section 12.1.1 "CLR, SET and INV Registers" for more information.

**TABLE 4-3: INTERRUPT REGISTER MAP FOR PIC32MX675F256H, PIC32MX675F512H AND PIC32MX695F512H DEVICES<sup>(1)</sup>**

Virtual Address (BF68_#)	Register Name	Bit Range	Bits															All Resets				
			31/15	30/14	29/13	28/12	27/11	26/10	25/9	24/8	23/7	22/6	21/5	20/4	19/3	18/2	17/1		16/0			
10D0	IPC4	31:16	—	—	—	INT4IP<2:0>			INT4IS<1:0>			—	—	—	OC4IP<2:0>			OC4IS<1:0>		0000		
		15:0	—	—	—	IC4IP<2:0>			IC4IS<1:0>			—	—	—	T4IP<2:0>			T4IS<1:0>		0000		
10E0	IPC5	31:16	—	—	—	—	—	—	—	—	—	—	—	—	OC5IP<2:0>			OC5IS<1:0>		0000		
		15:0	—	—	—	IC5IP<2:0>			IC5IS<1:0>			—	—	—	T5IP<2:0>			T5IS<1:0>		0000		
10F0	IPC6	31:16	—	—	—	AD1IP<2:0>			AD1IS<1:0>			—	—	—	CNIP<2:0>			CNIS<1:0>		0000		
		15:0	—	—	—	I2C1IP<2:0>			I2C1IS<1:0>			—	—	—	U1AIP<2:0>			U1AIS<1:0>		0000		
			—	—	—	SPI1AIP<2:0>			SPI1AIS<1:0>													
			—	—	—	I2C1AIP<2:0>			I2C1AIS<1:0>													
1100	IPC7	31:16	—	—	—	U2AIP<2:0>			U2AIS<1:0>			—	—	—	CMP2IP<2:0>			CMP2IS<1:0>		0000		
			—	—	—	SPI2AIP<2:0>			SPI2AIS<1:0>													
			—	—	—	I2C2AIP<2:0>			I2C2AIS<1:0>													
1110	IPC8	15:0	—	—	—	CMP1IP<2:0>			CMP1IS<1:0>			—	—	—	PMPIP<2:0>			PMPIS<1:0>		0000		
			31:16	—	—	—	RTCCIP<2:0>			RTCCIS<1:0>			—	—	—	FSCMIP<2:0>			FSCMIS<1:0>		0000	
			—	—	—	—	—	—	—	—	—	—	—	—	U3AIP<2:0>			U3AIS<1:0>				
1120	IPC9	31:16	—	—	—	DMA3IP<2:0>			DMA3IS<1:0>			—	—	—	DMA2IP<2:0>			DMA2IS<1:0>		0000		
			15:0	—	—	—	DMA1IP<2:0>			DMA1IS<1:0>			—	—	—	DMA0IP<2:0>			DMA0IS<1:0>			
			31:16	—	—	—	DMA7IP<2:0>			DMA7IS<1:0>			—	—	—	DMA6IP<2:0>			DMA6IS<1:0>		0000	
1130	IPC10	15:0	—	—	—	DMA5IP<2:0>			DMA5IS<1:0>			—	—	—	DMA4IP<2:0>			DMA4IS<1:0>		0000		
			31:16	—	—	—	—	—	—	—	—	—	—	—	—	—	—	—	—		—	0000
1140	IPC11	31:16	—	—	—	—	—	—	—	—	—	—	—	—	—	—	—	—	—	0000		
			15:0	—	—	—	USBIP<2:0>			USBIS<1:0>			—	—	—	FCEIP<2:0>			FCEIS<1:0>		0000	
1150	IPC12	31:16	—	—	—	U3BIP<2:0>			U3BIS<1:0>			—	—	—	U2BIP<2:0>			U2BIS<1:0>		0000		
			15:0	—	—	—	U1BIP<2:0>			U1BIS<1:0>			—	—	—	ETHIP<2:0>			ETHIS<1:0>		0000	

**Legend:** x = unknown value on Reset; — = unimplemented, read as '0'. Reset values are shown in hexadecimal.

**Note 1:** All registers in this table have corresponding CLR, SET and INV registers at their virtual addresses, plus offsets of 0x4, 0x8 and 0xC respectively. See Section 12.1.1 "CLR, SET and INV Registers" for more information.

**TABLE 4-4: INTERRUPT REGISTER MAP FOR PIC32MX775F256H, PIC32MX775F512H AND PIC32MX795F512H DEVICES<sup>(1)</sup>**

Virtual Address (BF88_#)	Register Name	Bit Range	Bits																All Resets																	
			31/15	30/14	29/13	28/12	27/11	26/10	25/9	24/8	23/7	22/6	21/5	20/4	19/3	18/2	17/1	16/0																		
1000	INTCON	31:16	—	—	—	—	—	—	—	—	—	—	—	—	—	—	—	SS0	0000																	
		15:0	—	FRZ	—	MVEC	—	TPC<2:0>			—	—	—	—	INT4EP	INT3EP	INT2EP	INT1EP	INT0EP	0000																
1010	INTSTAT	31:16	—	—	—	—	—	—	—	—	—	—	—	—	—	—	—	—	0000																	
		15:0	—	—	—	—	—	RIPL<2:0>			—	—	VEC<5:0>					0000																		
1020	IPTMR	31:16	IPTMR<31:0>																0000																	
		15:0																	0000																	
1030	IFS0	31:16	I2C1MIF	I2C1SIF	I2C1BIF	U1ATXIF	U1ARXIF	U1AEIF	—	—	—	OC5IF	IC5IF	T5IF	INT4IF	OC4IF	IC4IF	T4IF	0000																	
						SPI1ATXIF	SPI1ARXIF	SPI1AEIF																												
						I2C1AMIF	I2C1ASIF	I2C1ABIF																												
1040	IFS1	15:0	RTCCIF	FSCMIF	—	—	—	—	—	—	—	—	—	—	—	—	—	—	—	0000																
																					INT3IF	OC3IF	IC3IF	T3IF	INT2IF	OC2IF	IC2IF	T2IF	INT1IF	OC1IF	IC1IF	T1IF	INT0IF	CS1IF	CS0IF	CTIF
																					IC3EIF	IC2EIF	IC1EIF	ETHIF	CAN2IF	CAN1IF	USBIF	FCEIF	DMA7IF	DMA6IF	DMA5IF	DMA4IF	DMA3IF	DMA2IF	DMA1IF	DMA0IF
1050	IFS2	15:0	—	—	—	—	—	—	—	—	—	—	—	—	—	—	—	—	—	0000																
																					U3ATXIF	U3ARXIF	U3AEIF	U2ATXIF	U2ARXIF	U2AEIF										
																					SPI3ATXIF	SPI3ARXIF	SPI3AEIF	SPI2ATXIF	SPI2ARXIF	SPI2AEIF										
1060	IEC0	31:16	I2C1MIE	I2C1SIE	I2C1BIE	U1ATXIE	U1ARXIE	U1AEIE	—	—	—	OC5IE	IC5IE	T5IE	INT4IE	OC4IE	IC4IE	T4IE	0000																	
						SPI1ATXIE	SPI1ARXIE	SPI1AEIE																												
						I2C1AMIE	I2C1ASIE	I2C1ABIE																												
1070	IEC1	15:0	RTCCIE	FSCMIE	—	—	—	—	—	—	—	—	—	—	—	—	—	—	—	0000																
																					INT3IE	OC3IE	IC3IE	T3IE	INT2IE	OC2IE	IC2IE	T2IE	INT1IE	OC1IE	IC1IE	T1IE	INT0IE	CS1IE	CS0IE	CTIE
																					IC3EIE	IC2EIE	IC1EIE	ETHIE	CAN2IE	CAN1IE	USBIE	FCEIE	DMA7IE	DMA6IE	DMA5IE	DMA4IE	DMA3IE	DMA2IE	DMA1IE	DMA0IE
1080	IEC2	15:0	—	—	—	—	—	—	—	—	—	—	—	—	—	—	—	—	—	0000																
																					U3ATXIE	U3ARXIE	U3AEIE	U2ATXIE	U2ARXIE	U2AEIE										
																					SPI3ATXIE	SPI3ARXIE	SPI3AEIE	SPI2ATXIE	SPI2ARXIE	SPI2AEIE										
1090	IPC0	31:16	—	—	—	INT0IP<2:0>			INT0IS<1:0>			—	—	CS1IP<2:0>			CS1IS<1:0>		0000																	
		15:0	—	—	—	CS0IP<2:0>			CS0IS<1:0>			—	—	CTIP<2:0>			CTIS<1:0>		0000																	
10A0	IPC1	31:16	—	—	—	INT1IP<2:0>			INT1IS<1:0>			—	—	OC1IP<2:0>			OC1IS<1:0>		0000																	
		15:0	—	—	—	IC1IP<2:0>			IC1IS<1:0>			—	—	T1IP<2:0>			T1IS<1:0>		0000																	
10B0	IPC2	31:16	—	—	—	INT2IP<2:0>			INT2IS<1:0>			—	—	OC2IP<2:0>			OC2IS<1:0>		0000																	
		15:0	—	—	—	IC2IP<2:0>			IC2IS<1:0>			—	—	T2IP<2:0>			T2IS<1:0>		0000																	
10C0	IPC3	31:16	—	—	—	INT3IP<2:0>			INT3IS<1:0>			—	—	OC3IP<2:0>			OC3IS<1:0>		0000																	
		15:0	—	—	—	IC3IP<2:0>			IC3IS<1:0>			—	—	T3IP<2:0>			T3IS<1:0>		0000																	
10D0	IPC4	31:16	—	—	—	INT4IP<2:0>			INT4IS<1:0>			—	—	OC4IP<2:0>			OC4IS<1:0>		0000																	
		15:0	—	—	—	IC4IP<2:0>			IC4IS<1:0>			—	—	T4IP<2:0>			T4IS<1:0>		0000																	

**Legend:** x = unknown value on Reset; — = unimplemented, read as '0'. Reset values are shown in hexadecimal.

**Note 1:** All registers in this table have corresponding CLR, SET and INV registers at their virtual addresses, plus offsets of 0x4, 0x8 and 0xC, respectively. See Section 12.1.1 "CLR, SET and INV Registers" for more information.



**TABLE 4-4: INTERRUPT REGISTER MAP FOR PIC32MX775F256H, PIC32MX775F512H AND PIC32MX795F512H DEVICES<sup>(1)</sup>**

Virtual Address (BF88_#)	Register Name	Bit Range	Bits															All Resets
			31/15	30/14	29/13	28/12	27/11	26/10	25/9	24/8	23/7	22/6	21/5	20/4	19/3	18/2	17/1	
10E0	IPC5	31:16	—	—	—	—	—	—	—	—	—	—	—	—	OC5IP<2:0>		OC5IS<1:0>	0000
		15:0	—	—	—	IC5IP<2:0>			IC5IS<1:0>			—	—	—	T5IP<2:0>		T5IS<1:0>	0000
10F0	IPC6	31:16	—	—	—	AD1IP<2:0>			AD1IS<1:0>			—	—	—	CNIP<2:0>		CNIS<1:0>	0000
		15:0	—	—	—	I2C1IP<2:0>	I2C1IS<1:0>	—	—	—	U1AIP<2:0>		U1AIS<1:0>	0000				
											SPI1AIP<2:0>		SPI1AIS<1:0>					
											I2C1AIP<2:0>		I2C1AIS<1:0>					
1100	IPC7	31:16	—	—	—	U2AIP<2:0>		U2AIS<1:0>	—	—	—	CMP2IP<2:0>		CMP2IS<1:0>	0000			
						SPI2AIP<2:0>		SPI2AIS<1:0>										
						I2C2AIP<2:0>		I2C2AIS<1:0>										
1110	IPC8	15:0	—	—	—	—	—	—	—	—	—	—	—	PMP1IP<2:0>		PMP1IS<1:0>	0000	
														RTCC1IP<2:0>		RTCC1IS<1:0>		
														FSCMIP<2:0>		FSCMIS<1:0>		
1120	IPC9	31:16	—	—	—	DMA3IP<2:0>		DMA3IS<1:0>	—	—	—	DMA2IP<2:0>		DMA2IS<1:0>	0000			
						DMA1IP<2:0>		DMA1IS<1:0>				DMA0IP<2:0>		DMA0IS<1:0>				
						DMA7IP<2:0>		DMA7IS<1:0>				DMA6IP<2:0>		DMA6IS<1:0>				
1130	IPC10	31:16	—	—	—	DMA5IP<2:0>			DMA5IS<1:0>			—	—	—	DMA4IP<2:0>		DMA4IS<1:0>	0000
		15:0	—	—	—	CAN2IP<2:0>			CAN2IS<1:0>			—	—	—	CAN1IP<2:0>		CAN1IS<1:0>	0000
1140	IPC11	31:16	—	—	—	USBIP<2:0>			USBIS<1:0>			—	—	—	FCEIP<2:0>		FCEIS<1:0>	0000
		15:0	—	—	—	U3BIP<2:0>			U3BIS<1:0>			—	—	—	U2BIP<2:0>		U2BIS<1:0>	0000
1150	IPC12	31:16	—	—	—	U1BIP<2:0>			U1BIS<1:0>			—	—	—	ETHIP<2:0>		ETHIS<1:0>	0000
		15:0	—	—	—	—			—			—		—		—		0000

**Legend:** x = unknown value on Reset; — = unimplemented, read as '0'. Reset values are shown in hexadecimal.

**Note 1:** All registers in this table have corresponding CLR, SET and INV registers at their virtual addresses, plus offsets of 0x4, 0x8 and 0xC, respectively. See Section 12.1.1 "CLR, SET and INV Registers" for more information.

TABLE 4-5: INTERRUPT REGISTER MAP FOR PIC32MX575F512L AND PIC32MX575F256L DEVICES<sup>(1)</sup>

Virtual Address (BF88 #)	Register Name	Bit Range	Bits																All Resets	
			31/15	30/14	29/13	28/12	27/11	26/10	25/9	24/8	23/7	22/6	21/5	20/4	19/3	18/2	17/1	16/0		
1000	INTCON	31:16	—	—	—	—	—	—	—	—	—	—	—	—	—	—	—	SS0	0000	
		15:0	—	FRZ	—	MVEC	—	TPC<2:0>			—	—	—	—	INT4EP	INT3EP	INT2EP	INT1EP	INT0EP	0000
1010	INTSTAT	31:16	—	—	—	—	—	—	—	—	—	—	—	—	—	—	—	—	0000	
		15:0	—	—	—	—	—	RIPL<2:0>			—	—	VEC<5:0>					0000		
1020	IPTMR	31:16	IPTMR<31:0>																0000	
		15:0																	0000	
1030	IFS0	31:16	I2C1MIF	I2C1SIF	I2C1BIF	U1ATXIF	U1ARXIF	U1AEIF	SPI1TXIF	SPI1RXIF	SPI1EIF	OC5IF	IC5IF	T5IF	INT4IF	OC4IF	IC4IF	T4IF		0000
			SPI1ATXIF	SPI1ARXIF	SPI1AEIF	I2C1AMIF	I2C1ASIF	I2C1ABIF												
1040	IFS1	15:0	INT3IF	OC3IF	IC3IF	T3IF	INT2IF	OC2IF	IC2IF	T2IF	INT1IF	OC1IF	IC1IF	T1IF	INT0IF	CS1IF	CS0IF	CTIF		0000
		31:16	IC3EIF	IC2EIF	IC1EIF	—	—	CAN1IF	USBIF	FCEIF	DMA7IF	DMA6IF	DMA5IF	DMA4IF	DMA3IF	DMA2IF	DMA1IF	DMA0IF		0000
1050	IFS2	15:0	RTCCIF	FSCMIF	I2C2MIF	I2C2SIF	I2C2BIF	U3ATXIF	U3ARXIF	U3AEIF	U2ATXIF	U2ARXIF	U2AEIF	CMP2IF	CMP1IF	PMPIF	AD1IF	CNIF		0000
		31:16	—	—	—	—	—	—	—	—	—	—	—							
1060	IEC0	15:0	—	—	—	—	—	U3BTXIF	U3BRXIF	U3BEIF	U2BTXIF	U2BRXIF	U2BEIF	U1BTXIF	U1BRXIF	U1BEIF	PMPEIF	IC5EIF	IC4EIF	0000
		31:16	I2C1MIE	I2C1SIE	I2C1BIE	U1ATXIE	U1ARXIE	U1AEIE	SPI1TXIE	SPI1RXIE	SPI1EIE	OC5IE	IC5IE	T5IE	INT4IE	OC4IE	IC4IE	T4IE		0000
	SPI1ATXIE	SPI1ARXIE	SPI1AEIE	I2C1AMIE	I2C1ASIE	I2C1ABIE														
1070	IEC1	15:0	INT3IE	OC3IE	IC3IE	T3IE	INT2IE	OC2IE	IC2IE	T2IE	INT1IE	OC1IE	IC1IE	T1IE	INT0IE	CS1IE	CS0IE	CTIE		0000
		31:16	IC3EIE	IC2EIE	IC1EIE	—	—	CAN1IE	USBIE	FCEIE	DMA7IE	DMA6IE	DMA5IE	DMA4IE	DMA3IE	DMA2IE	DMA1IE	DMA0IE		0000
1080	IEC2	15:0	—	—	—	—	—	—	—	—	—	—	—	—	—	—	—	—	—	0000
		31:16	—	—	—	—	—	U3BTXIE	U3BRXIE	U3BEIE	U2BTXIE	U2BRXIE	U2BEIE	U1BTXIE	U1BRXIE	U1BEIE	PMPEIE	IC5EIE	IC4EIE	0000
1090	IPC0	15:0	—	—	—	—	—	—	—	—	—	—	—	—	—	—	—	—	—	0000
		31:16	—	—	—	INT0IP<2:0>			INT0IS<1:0>			—	—	CS1IP<2:0>			CS1IS<1:0>		0000	
10A0	IPC1	15:0	—	—	—	—	—	—	—	—	—	—	—	—	—	—	—	—	—	0000
		31:16	—	—	—	INT1IP<2:0>			INT1IS<1:0>			—	—	OC1IP<2:0>			OC1IS<1:0>		0000	
10B0	IPC2	15:0	—	—	—	—	—	—	—	—	—	—	—	—	—	—	—	—	—	0000
		31:16	—	—	—	INT2IP<2:0>			INT2IS<1:0>			—	—	OC2IP<2:0>			OC2IS<1:0>		0000	
10C0	IPC3	15:0	—	—	—	—	—	—	—	—	—	—	—	—	—	—	—	—	—	0000
		31:16	—	—	—	INT3IP<2:0>			INT3IS<1:0>			—	—	OC3IP<2:0>			OC3IS<1:0>		0000	
10D0	IPC4	15:0	—	—	—	—	—	—	—	—	—	—	—	—	—	—	—	—	—	0000
		31:16	—	—	—	INT4IP<2:0>			INT4IS<1:0>			—	—	OC4IP<2:0>			OC4IS<1:0>		0000	
		15:0	—	—	—	—	—	—	—	—	—	—	—	—	—	—	—	—	—	0000

**Legend:** x = unknown value on Reset; — = unimplemented, read as '0'. Reset values are shown in hexadecimal.

**Note 1:** All registers in this table have corresponding CLR, SET and INV registers at their virtual addresses, plus offsets of 0x4, 0x8 and 0xC, respectively. See Section 12.1.1 "CLR, SET and INV Registers" for more information.

**TABLE 4-5: INTERRUPT REGISTER MAP FOR PIC32MX575F512L AND PIC32MX575F256L DEVICES<sup>(1)</sup> (CONTINUED)**

Virtual Address (BF88_#)	Register Name	Bit Range	Bits															All Resets			
			31/15	30/14	29/13	28/12	27/11	26/10	25/9	24/8	23/7	22/6	21/5	20/4	19/3	18/2	17/1		16/0		
10E0	IPC5	31:16	—	—	—	SPI1IP<2:0>			SPI1IS<1:0>			—	—	—	OC5IP<2:0>			OC5IS<1:0>		0000	
		15:0	—	—	—	IC5IP<2:0>			IC5IS<1:0>			—	—	—	T5IP<2:0>			T5IS<1:0>		0000	
10F0	IPC6	31:16	—	—	—	AD1IP<2:0>			AD1IS<1:0>			—	—	—	CNIP<2:0>			CNIS<1:0>		0000	
		15:0	—	—	—	I2C1IP<2:0>			I2C1IS<1:0>			—	—	—	U1AIP<2:0>			U1AIS<1:0>		0000	
															SPI1AIP<2:0>			SPI1AIS<1:0>			
															I2C1AIP<2:0>			I2C1AIS<1:0>			
1100	IPC7	31:16	—	—	—	U2AIP<2:0>			U2AIS<1:0>			—	—	—	CMP2IP<2:0>			CMP2IS<1:0>		0000	
						SPI2AIP<2:0>			SPI2AIS<1:0>												
						I2C2AIP<2:0>			I2C2AIS<1:0>												
1110	IPC8	15:0	—	—	—	CMP1IP<2:0>			CMP1IS<1:0>			—	—	—	PMPIP<2:0>			PMPIS<1:0>		0000	
						RTCCIP<2:0>			RTCCIS<1:0>						FSCMIP<2:0>			FSCMIS<1:0>			
						I2C2IP<2:0>			I2C2IS<1:0>						—	—	—	U3AIP<2:0>			U3AIS<1:0>
SPI3AIP<2:0>			SPI3AIS<1:0>																		
1120	IPC9	31:16	—	—	—	DMA3IP<2:0>			DMA3IS<1:0>			—	—	—	DMA2IP<2:0>			DMA2IS<1:0>		0000	
		15:0	—	—	—	DMA1IP<2:0>			DMA1IS<1:0>			—	—	—	DMA0IP<2:0>			DMA0IS<1:0>		0000	
1130	IPC10	31:16	—	—	—	DMA7IP<2:0>			DMA7IS<1:0>			—	—	—	DMA6IP<2:0>			DMA6IS<1:0>		0000	
		15:0	—	—	—	DMA5IP<2:0>			DMA5IS<1:0>			—	—	—	DMA4IP<2:0>			DMA4IS<1:0>		0000	
1140	IPC11	31:16	—	—	—	—	—	—	—	—	—	—	—	—	—	CAN1IP<2:0>			CAN1IS<1:0>		0000
		15:0	—	—	—	USBIP<2:0>			USBIS<1:0>			—	—	—	FCEIP<2:0>			FCEIS<1:0>		0000	
1150	IPC12	31:16	—	—	—	U3BIP<2:0>			U3BIS<1:0>			—	—	—	U2BIP<2:0>			U2BIS<1:0>		0000	
		15:0	—	—	—	U1BIP<2:0>			U1BIS<1:0>			—	—	—	—	—	—	—	—	0000	

**Legend:** x = unknown value on Reset; — = unimplemented, read as '0'. Reset values are shown in hexadecimal.

**Note 1:** All registers in this table have corresponding CLR, SET and INV registers at their virtual addresses, plus offsets of 0x4, 0x8 and 0xC, respectively. See Section 12.1.1 "CLR, SET and INV Registers" for more information.

**TABLE 4-6: INTERRUPT REGISTER MAP FOR PIC32MX675F256L, PIC32MX675F512L AND PIC32MX695F512L DEVICES<sup>(1)</sup>**

Virtual Address (BF88_#)	Register Name	Bit Range	Bits																All Resets
			31/15	30/14	29/13	28/12	27/11	26/10	25/9	24/8	23/7	22/6	21/5	20/4	19/3	18/2	17/1	16/0	
1000	INTCON	31:16	—	—	—	—	—	—	—	—	—	—	—	—	—	—	—	SS0	0000
		15:0	—	FRZ	—	MVEC	—	TPC<2:0>			—	—	—	—	INT4EP	INT3EP	INT2EP	INT1EP	INT0EP
1010	INTSTAT	31:16	—	—	—	—	—	—	—	—	—	—	—	—	—	—	—	—	0000
		15:0	—	—	—	—	—	RIPL<2:0>			—	—	VEC<5:0>					0000	
1020	IPTMR	31:16	IPTMR<31:0>																0000
		15:0																	0000
1030	IFS0	31:16	I2C1MIF	I2C1SIF	I2C1BIF	U1ATXIF SPI1ATXIF I2C1AMIF	U1ARXIF SPI1ARXIF I2C1ASIF	U1AEIF SPI1AEIF I2C1ABIF	SPI1TXIF	SPI1RXIF	SPI1EIF	OC5IF	IC5IF	T5IF	INT4IF	OC4IF	IC4IF	T4IF	0000
		15:0	INT3IF	OC3IF	IC3IF	T3IF	INT2IF	OC2IF	IC2IF	T2IF	INT1IF	OC1IF	IC1IF	T1IF	INT0IF	CS1IF	CS0IF	CTIF	0000
1040	IFS1	31:16	IC3EIF	IC2EIF	IC1EIF	ETHIF	—	—	USBIF	FCEIF	DMA7IF	DMA6IF	DMA5IF	DMA4IF	DMA3IF	DMA2IF	DMA1IF	DMA0IF	0000
		15:0	RTCCIF	FSCMIF	I2C2MIF	I2C2SIF	I2C2BIF	U3ATXIF SPI3ATXIF I2C3AMIF	U3ARXIF SPI3ARXIF I2C3ASIF	U3AEIF SPI3AEIF I2C3ASIF	U2ATXIF SPI2ATXIF I2C2AMIF	U2ARXIF SPI2ARXIF I2C2ASIF	U2AEIF SPI2AEIF I2C2ABIF	CMP2IF	CMP1IF	PMPIF	AD1IF	CNIF	0000
1050	IFS2	31:16	—	—	—	—	—	—	—	—	—	—	—	—	—	—	—	—	0000
		15:0	—	—	—	—	—	U3BTXIF	U3BRXIF	U3BEIF	U2BTXIF	U2BRXIF	U2BEIF	U1BTXIF	U1BRXIF	U1BEIF	PMPEIF	IC5EIF	IC4EIF
1060	IEC0	31:16	I2C1MIE	I2C1SIE	I2C1BIE	U1ATXIE SPI1ATXIE I2C1AMIE	U1ARXIE SPI1ARXIE I2C1ASIE	U1AEIE SPI1AEIE I2C1ABIE	SPI1TXIE	SPI1RXIE	SPI1EIE	OC5IE	IC5IE	T5IE	INT4IE	OC4IE	IC4IE	T4IE	0000
		15:0	INT3IE	OC3IE	IC3IE	T3IE	INT2IE	OC2IE	IC2IE	T2IE	INT1IE	OC1IE	IC1IE	T1IE	INT0IE	CS1IE	CS0IE	CTIE	0000
1070	IEC1	31:16	IC3EIE	IC2EIE	IC1EIE	ETHIE	—	—	USBIE	FCEIE	DMA7IE	DMA6IE	DMA5IE	DMA4IE	DMA3IE	DMA2IE	DMA1IE	DMA0IE	0000
		15:0	RTCCIE	FSCMIE	I2C2MIE	I2C2SIE	I2C2BIE	U3ATXIE SPI3ATXIE I2C3AMIE	U3ARXIE SPI3ARXIE I2C3ASIE	U3AEIE SPI3AEIE I2C3ASIE	U2ATXIE SPI2ATXIE I2C2AMIE	U2ARXIE SPI2ARXIE I2C2ASIE	U2AEIE SPI2AEIE I2C2ABIE	CMP2IE	CMP1IE	PMPIE	AD1IE	CNIE	0000
1080	IEC2	31:16	—	—	—	—	—	—	—	—	—	—	—	—	—	—	—	—	0000
		15:0	—	—	—	—	—	U3BTXIE	U3BRXIE	U3BEIE	U2BTXIE	U2BRXIE	U2BEIE	U1BTXIE	U1BRXIE	U1BEIE	PMPEIE	IC5EIE	IC4EIE
1090	IPC0	31:16	—	—	—	INT0IP<2:0>			INT0IS<1:0>			—	—	CS1IP<2:0>			CS1IS<1:0>		0000
		15:0	—	—	—	CS0IP<2:0>			CS0IS<1:0>			—	—	CTIP<2:0>			CTIS<1:0>		0000
10A0	IPC1	31:16	—	—	—	INT1IP<2:0>			INT1IS<1:0>			—	—	OC1IP<2:0>			OC1IS<1:0>		0000
		15:0	—	—	—	IC1IP<2:0>			IC1IS<1:0>			—	—	T1IP<2:0>			T1IS<1:0>		0000
10B0	IPC2	31:16	—	—	—	INT2IP<2:0>			INT2IS<1:0>			—	—	OC2IP<2:0>			OC2IS<1:0>		0000
		15:0	—	—	—	IC2IP<2:0>			IC2IS<1:0>			—	—	T2IP<2:0>			T2IS<1:0>		0000
10C0	IPC3	31:16	—	—	—	INT3IP<2:0>			INT3IS<1:0>			—	—	OC3IP<2:0>			OC3IS<1:0>		0000
		15:0	—	—	—	IC3IP<2:0>			IC3IS<1:0>			—	—	T3IP<2:0>			T3IS<1:0>		0000
10D0	IPC4	31:16	—	—	—	INT4IP<2:0>			INT4IS<1:0>			—	—	OC4IP<2:0>			OC4IS<1:0>		0000
		15:0	—	—	—	IC4IP<2:0>			IC4IS<1:0>			—	—	T4IP<2:0>			T4IS<1:0>		0000

**Legend:** x = unknown value on Reset; — = unimplemented, read as '0'. Reset values are shown in hexadecimal.

**Note 1:** All registers in this table have corresponding CLR, SET and INV registers at their virtual addresses, plus offsets of 0x4, 0x8 and 0xC, respectively. See Section 12.1.1 “CLR, SET and INV Registers” for more information.

**TABLE 4-6: INTERRUPT REGISTER MAP FOR PIC32MX675F256L, PIC32MX675F512L AND PIC32MX695F512L DEVICES<sup>(1)</sup> (CONTINUED)**

Virtual Address (BF88_#)	Register Name	Bit Range	Bits														All Resets			
			31/15	30/14	29/13	28/12	27/11	26/10	25/9	24/8	23/7	22/6	21/5	20/4	19/3	18/2		17/1	16/0	
10E0	IPC5	31:16	—	—	—	SPI1IP<2:0>			SPI1IS<1:0>			—	—	—	OC5IP<2:0>			OC5IS<1:0>		0000
		15:0	—	—	—	IC5IP<2:0>			IC5IS<1:0>			—	—	—	T5IP<2:0>			T5IS<1:0>		0000
10F0	IPC6	31:16	—	—	—	AD1IP<2:0>			AD1IS<1:0>			—	—	—	CNIP<2:0>			CNIS<1:0>		0000
		15:0	—	—	—	I2C1IP<2:0>			I2C1IS<1:0>			—	—	—	U1AIP<2:0>			U1AIS<1:0>		0000
															SPI1AIP<2:0>			SPI1AIS<1:0>		
															I2C1AIP<2:0>			I2C1AIS<1:0>		
1100	IPC7	31:16	—	—	—	U2AIP<2:0>			U2AIS<1:0>			—	—	—	CMP2IP<2:0>			CMP2IS<1:0>		0000
						SPI2AIP<2:0>			SPI2AIS<1:0>											
						I2C2AIP<2:0>			I2C2AIS<1:0>											
1110	IPC8	31:16	—	—	—	CMP1IP<2:0>			CMP1IS<1:0>			—	—	—	PMP1IP<2:0>			PMP1IS<1:0>		0000
		15:0	—	—	—	RTCCIP<2:0>			RTCCIS<1:0>			—	—	—	FSCMIP<2:0>			FSCMIS<1:0>		0000
1120	IPC9	31:16	—	—	—	DMA3IP<2:0>			DMA3IS<1:0>			—	—	—	DMA2IP<2:0>			DMA2IS<1:0>		0000
		15:0	—	—	—	DMA1IP<2:0>			DMA1IS<1:0>			—	—	—	DMA0IP<2:0>			DMA0IS<1:0>		0000
1130	IPC10	31:16	—	—	—	DMA7IP<2:0>			DMA7IS<1:0>			—	—	—	DMA6IP<2:0>			DMA6IS<1:0>		0000
		15:0	—	—	—	DMA5IP<2:0>			DMA5IS<1:0>			—	—	—	DMA4IP<2:0>			DMA4IS<1:0>		0000
1140	IPC11	31:16	—	—	—	—	—	—	—	—	—	—	—	—	—	—	—	—	—	0000
		15:0	—	—	—	USBIP<2:0>			USBIS<1:0>			—	—	—	FCEIP<2:0>			FCEIS<1:0>		0000
1150	IPC12	31:16	—	—	—	U3BIP<2:0>			U3BIS<1:0>			—	—	—	U2BIP<2:0>			U2BIS<1:0>		0000
		15:0	—	—	—	U1BIP<2:0>			U1BIS<1:0>			—	—	—	ETHIP<2:0>			ETHIS<1:0>		0000

**Legend:** x = unknown value on Reset; — = unimplemented, read as '0'. Reset values are shown in hexadecimal.

**Note 1:** All registers in this table have corresponding CLR, SET and INV registers at their virtual addresses, plus offsets of 0x4, 0x8 and 0xC, respectively. See Section 12.1.1 "CLR, SET and INV Registers" for more information.

**TABLE 4-7: INTERRUPT REGISTER MAP FOR PIC32MX775F256L, PIC32MX775F512L AND PIC32MX795F512L DEVICES<sup>(1)</sup>**

Virtual Address (BF88_#)	Register Name	Bit Range	Bits																All Resets
			31/15	30/14	29/13	28/12	27/11	26/10	25/9	24/8	23/7	22/6	21/5	20/4	19/3	18/2	17/1	16/0	
1000	INTCON	31:16	—	—	—	—	—	—	—	—	—	—	—	—	—	—	—	SS0	0000
		15:0	—	FRZ	—	MVEC	—	TPC<2:0>			—	—	—	—	INT4EP	INT3EP	INT2EP	INT1EP	INT0EP
1010	INTSTAT	31:16	—	—	—	—	—	—	—	—	—	—	—	—	—	—	—	—	0000
		15:0	—	—	—	—	—	RIPL<2:0>			—	—	VEC<5:0>					0000	
1020	IPTMR	31:16	IPTMR<31:0>																0000
		15:0																	0000
1030	IFS0	31:16	I2C1MIF	I2C1SIF	I2C1BIF	U1ATXIF SPI1ATXIF I2C1AMIF	U1ARXIF SPI1ARXIF I2C1ASIF	U1AEIF SPI1AEIF I2C1ABIF	SPI1TXIF	SPI1RXIF	SPI1EIF	OC5IF	IC5IF	T5IF	INT4IF	OC4IF	IC4IF	T4IF	0000
		15:0	INT3IF	OC3IF	IC3IF	T3IF	INT2IF	OC2IF	IC2IF	T2IF	INT1IF	OC1IF	IC1IF	T1IF	INT0IF	CS1IF	CS0IF	CTIF	0000
1040	IFS1	31:16	IC3EIF	IC2EIF	IC1EIF	ETHIF	CAN2IF	CAN1IF	USBIF	FCEIF	DMA7IF	DMA6IF	DMA5IF	DMA4IF	DMA3IF	DMA2IF	DMA1IF	DMA0IF	0000
		15:0	RTCCIF	FSCMIF	I2C2MIF	I2C2SIF	I2C2BIF	U3ATXIF SPI3ATXIF I2C3AMIF	U3ARXIF SPI3ARXIF I2C3ASIF	U3AEIF SPI3AEIF I2C3ASIF	U2ATXIF SPI2ATXIF I2C2AMIF	U2ARXIF SPI2ARXIF I2C2ASIF	U2AEIF SPI2AEIF I2C2ABIF	CMP2IF	CMP1IF	PMPIF	AD1IF	CNIF	0000
1050	IFS2	31:16	—	—	—	—	—	—	—	—	—	—	—	—	—	—	—	—	0000
		15:0	—	—	—	—	—	U3BTXIF	U3BRXIF	U3BEIF	U2BTXIF	U2BRXIF	U2BEIF	U1BTXIF	U1BRXIF	U1BEIF	PMPEIF	IC5EIF	IC4EIF
1060	IEC0	31:16	I2C1MIE	I2C1SIE	I2C1BIE	U1ATXIE SPI1ATXIE I2C1AMIE	U1ARXIE SPI1ARXIE I2C1ASIE	U1AEIE SPI1AEIE I2C1ABIE	SPI1TXIE	SPI1RXIE	SPI1EIE	OC5IE	IC5IE	T5IE	INT4IE	OC4IE	IC4IE	T4IE	0000
		15:0	INT3IE	OC3IE	IC3IE	T3IE	INT2IE	OC2IE	IC2IE	T2IE	INT1IE	OC1IE	IC1IE	T1IE	INT0IE	CS1IE	CS0IE	CTIE	0000
1070	IEC1	31:16	IC3EIE	IC2EIE	IC1EIE	ETHIE	CAN2IE	CAN1IE	USBIE	FCEIE	DMA7IE	DMA6IE	DMA5IE	DMA4IE	DMA3IE	DMA2IE	DMA1IE	DMA0IE	0000
		15:0	RTCCIE	FSCMIE	I2C2MIE	I2C2SIE	I2C2BIE	U3ATXIE SPI3ATXIE I2C3AMIE	U3ARXIE SPI3ARXIE I2C3ASIE	U3AEIE SPI3AEIE I2C3ASIE	U2ATXIE SPI2ATXIE I2C2AMIE	U2ARXIE SPI2ARXIE I2C2ASIE	U2AEIE SPI2AEIE I2C2ABIE	CMP2IE	CMP1IE	PMPIE	AD1IE	CNIE	0000
1080	IEC2	31:16	—	—	—	—	—	—	—	—	—	—	—	—	—	—	—	—	0000
		15:0	—	—	—	—	—	U3BTXIE	U3BRXIE	U3BEIE	U2BTXIE	U2BRXIE	U2BEIE	U1BTXIE	U1BRXIE	U1BEIE	PMPEIE	IC5EIE	IC4EIE
1090	IPC0	31:16	—	—	—	INT0IP<2:0>			INT0IS<1:0>			—	—	CS1IP<2:0>			CS1IS<1:0>		0000
		15:0	—	—	—	CS0IP<2:0>			CS0IS<1:0>			—	—	CTIP<2:0>			CTIS<1:0>		0000
10A0	IPC1	31:16	—	—	—	INT1IP<2:0>			INT1IS<1:0>			—	—	OC1IP<2:0>			OC1IS<1:0>		0000
		15:0	—	—	—	IC1IP<2:0>			IC1IS<1:0>			—	—	T1IP<2:0>			T1IS<1:0>		0000
10B0	IPC2	31:16	—	—	—	INT2IP<2:0>			INT2IS<1:0>			—	—	OC2IP<2:0>			OC2IS<1:0>		0000
		15:0	—	—	—	IC2IP<2:0>			IC2IS<1:0>			—	—	T2IP<2:0>			T2IS<1:0>		0000
10C0	IPC3	31:16	—	—	—	INT3IP<2:0>			INT3IS<1:0>			—	—	OC3IP<2:0>			OC3IS<1:0>		0000
		15:0	—	—	—	IC3IP<2:0>			IC3IS<1:0>			—	—	T3IP<2:0>			T3IS<1:0>		0000
10D0	IPC4	31:16	—	—	—	INT4IP<2:0>			INT4IS<1:0>			—	—	OC4IP<2:0>			OC4IS<1:0>		0000
		15:0	—	—	—	IC4IP<2:0>			IC4IS<1:0>			—	—	T4IP<2:0>			T4IS<1:0>		0000

**Legend:** x = unknown value on Reset; — = unimplemented, read as '0'. Reset values are shown in hexadecimal.

**Note 1:** All registers in this table have corresponding CLR, SET and INV registers at their virtual addresses, plus offsets of 0x4, 0x8 and 0xC, respectively. See Section 12.1.1 "CLR, SET and INV Registers" for more information.

**TABLE 4-7: INTERRUPT REGISTER MAP FOR PIC32MX775F256L, PIC32MX775F512L AND PIC32MX795F512L DEVICES<sup>(1)</sup> (CONTINUED)**

Virtual Address (BF88_#)	Register Name	Bit Range	Bits														All Resets			
			31/15	30/14	29/13	28/12	27/11	26/10	25/9	24/8	23/7	22/6	21/5	20/4	19/3	18/2		17/1	16/0	
10E0	IPC5	31:16	—	—	—	SPI1IP<2:0>			SPI1IS<1:0>			—	—	OC5IP<2:0>			OC5IS<1:0>		0000	
		15:0	—	—	—	IC5IP<2:0>			IC5IS<1:0>			—	—	T5IP<2:0>			T5IS<1:0>		0000	
10F0	IPC6	31:16	—	—	—	AD1IP<2:0>			AD1IS<1:0>			—	—	CNIP<2:0>			CNIS<1:0>		0000	
		15:0	—	—	—	I2C1IP<2:0>			I2C1IS<1:0>			—	—	—	U1AIP<2:0>			U1AIS<1:0>		0000
															SPI1AIP<2:0>			SPI1AIS<1:0>		
															I2C1AIP<2:0>			I2C1AIS<1:0>		
1100	IPC7	31:16	—	—	—	U2AIP<2:0>			U2AIS<1:0>			—	—	—	CMP2IP<2:0>			CMP2IS<1:0>		0000
						SPI2AIP<2:0>			SPI2AIS<1:0>											
						I2C2AIP<2:0>			I2C2AIS<1:0>											
1110	IPC8	15:0	—	—	—	CMP1IP<2:0>			CMP1IS<1:0>			—	—	—	PMP1IP<2:0>			PMP1IS<1:0>		0000
						RTCCIP<2:0>			RTCCIS<1:0>						FSCMP<2:0>			FSCMIS<1:0>		
						I2C2IP<2:0>			I2C2IS<1:0>						—	—	—	U3AIP<2:0>		
SPI3AIP<2:0>			SPI3AIS<1:0>		I2C3AIP<2:0>			I2C3AIS<1:0>												
1120	IPC9	31:16	—	—	—	DMA3IP<2:0>			DMA3IS<1:0>			—	—	DMA2IP<2:0>			DMA2IS<1:0>		0000	
		15:0	—	—	—	DMA1IP<2:0>			DMA1IS<1:0>			—	—	DMA0IP<2:0>			DMA0IS<1:0>		0000	
1130	IPC10	31:16	—	—	—	DMA7IP<2:0>			DMA7IS<1:0>			—	—	DMA6IP<2:0>			DMA6IS<1:0>		0000	
		15:0	—	—	—	DMA5IP<2:0>			DMA5IS<1:0>			—	—	DMA4IP<2:0>			DMA4IS<1:0>		0000	
1140	IPC11	31:16	—	—	—	CAN2IP<2:0>			CAN2IS<1:0>			—	—	CAN1IP<2:0>			CAN1IS<1:0>		0000	
		15:0	—	—	—	USBIP<2:0>			USBIS<1:0>			—	—	FCEIP<2:0>			FCEIS<1:0>		0000	
1150	IPC12	31:16	—	—	—	U3BIP<2:0>			U3BIS<1:0>			—	—	U2BIP<2:0>			U2BIS<1:0>		0000	
		15:0	—	—	—	U1BIP<2:0>			U1BIS<1:0>			—	—	ETHIP<2:0>			ETHIS<1:0>		0000	

**Legend:** x = unknown value on Reset; — = unimplemented, read as '0'. Reset values are shown in hexadecimal.

**Note 1:** All registers in this table have corresponding CLR, SET and INV registers at their virtual addresses, plus offsets of 0x4, 0x8 and 0xC, respectively. See Section 12.1.1 "CLR, SET and INV Registers" for more information.

TABLE 4-8: TIMER1-TIMER5 REGISTER MAP<sup>(1)</sup>

Virtual Address (BF80_#)	Register Name	Bit Range	Bits															All Resets	
			31/15	30/14	29/13	28/12	27/11	26/10	25/9	24/8	23/7	22/6	21/5	20/4	19/3	18/2	17/1		16/0
0600	T1CON	31:16	—	—	—	—	—	—	—	—	—	—	—	—	—	—	—	—	0000
		15:0	ON	FRZ	SIDL	TWDIS	TWIP	—	—	—	TGATE	—	TCKPS<1:0>	—	TSYNC	TCS	—	—	0000
0610	TMR1	31:16	—	—	—	—	—	—	—	—	—	—	—	—	—	—	—	—	0000
		15:0	TMR1<15:0>															0000	
0620	PR1	31:16	—	—	—	—	—	—	—	—	—	—	—	—	—	—	—	—	0000
		15:0	PR1<15:0>															FFFF	
0800	T2CON	31:16	—	—	—	—	—	—	—	—	—	—	—	—	—	—	—	—	0000
		15:0	ON	FRZ	SIDL	—	—	—	—	—	TGATE	—	TCKPS<2:0>	—	T32	—	TCS	—	0000
0810	TMR2	31:16	—	—	—	—	—	—	—	—	—	—	—	—	—	—	—	—	0000
		15:0	TMR2<15:0>															0000	
0820	PR2	31:16	—	—	—	—	—	—	—	—	—	—	—	—	—	—	—	—	0000
		15:0	PR2<15:0>															FFFF	
0A00	T3CON	31:16	—	—	—	—	—	—	—	—	—	—	—	—	—	—	—	—	0000
		15:0	ON	FRZ	SIDL	—	—	—	—	—	TGATE	—	TCKPS<2:0>	—	—	—	TCS	—	0000
0A10	TMR3	31:16	—	—	—	—	—	—	—	—	—	—	—	—	—	—	—	—	0000
		15:0	TMR3<15:0>															0000	
0A20	PR3	31:16	—	—	—	—	—	—	—	—	—	—	—	—	—	—	—	—	0000
		15:0	PR3<15:0>															FFFF	
0C00	T4CON	31:16	—	—	—	—	—	—	—	—	—	—	—	—	—	—	—	—	0000
		15:0	ON	FRZ	SIDL	—	—	—	—	—	TGATE	—	TCKPS<2:0>	—	T32	—	TCS	—	0000
0C10	TMR4	31:16	—	—	—	—	—	—	—	—	—	—	—	—	—	—	—	—	0000
		15:0	TMR4<15:0>															0000	
0C20	PR4	31:16	—	—	—	—	—	—	—	—	—	—	—	—	—	—	—	—	0000
		15:0	PR4<15:0>															FFFF	
0E00	T5CON	31:16	—	—	—	—	—	—	—	—	—	—	—	—	—	—	—	—	0000
		15:0	ON	FRZ	SIDL	—	—	—	—	—	TGATE	—	TCKPS<2:0>	—	—	—	TCS	—	0000
0E10	TMR5	31:16	—	—	—	—	—	—	—	—	—	—	—	—	—	—	—	—	0000
		15:0	TMR5<15:0>															0000	
0E20	PR5	31:16	—	—	—	—	—	—	—	—	—	—	—	—	—	—	—	—	0000
		15:0	PR5<15:0>															FFFF	

**Legend:** x = unknown value on Reset; — = unimplemented, read as '0'. Reset values are shown in hexadecimal.

**Note 1:** All registers in this table have corresponding CLR, SET and INV registers at their virtual addresses, plus offsets of 0x4, 0x8 and 0xC, respectively. See Section 12.1.1 "CLR, SET and INV Registers" for more information.



**TABLE 4-9: INPUT CAPTURE 1-INPUT CAPTURE 5 REGISTER MAP**

Virtual Address (BF80_#)	Register Name	Bit Range	Bits															All Resets	
			31/15	30/14	29/13	28/12	27/11	26/10	25/9	24/8	23/7	22/6	21/5	20/4	19/3	18/2	17/1		16/0
2000	IC1CON <sup>(1)</sup>	31:16	—	—	—	—	—	—	—	—	—	—	—	—	—	—	—	—	0000
		15:0	ON	FRZ	SIDL	—	—	—	FEDGE	C32	ICTMR	ICI<1:0>	ICOV	ICBNE	ICM<2:0>	0000			
2010	IC1BUF	31:16	IC1BUF<31:0>															xxxx	
		15:0																xxxx	
2200	IC2CON <sup>(1)</sup>	31:16	—	—	—	—	—	—	—	—	—	—	—	—	—	—	—	—	0000
		15:0	ON	FRZ	SIDL	—	—	—	FEDGE	C32	ICTMR	ICI<1:0>	ICOV	ICBNE	ICM<2:0>	0000			
2210	IC2BUF	31:16	IC2BUF<31:0>															xxxx	
		15:0																xxxx	
2400	IC3CON <sup>(1)</sup>	31:16	—	—	—	—	—	—	—	—	—	—	—	—	—	—	—	—	0000
		15:0	ON	FRZ	SIDL	—	—	—	FEDGE	C32	ICTMR	ICI<1:0>	ICOV	ICBNE	ICM<2:0>	0000			
2410	IC3BUF	31:16	IC3BUF<31:0>															xxxx	
		15:0																xxxx	
2600	IC4CON <sup>(1)</sup>	31:16	—	—	—	—	—	—	—	—	—	—	—	—	—	—	—	—	0000
		15:0	ON	FRZ	SIDL	—	—	—	FEDGE	C32	ICTMR	ICI<1:0>	ICOV	ICBNE	ICM<2:0>	0000			
2610	IC4BUF	31:16	IC4BUF<31:0>															xxxx	
		15:0																xxxx	
2800	IC5CON <sup>(1)</sup>	31:16	—	—	—	—	—	—	—	—	—	—	—	—	—	—	—	—	0000
		15:0	ON	FRZ	SIDL	—	—	—	FEDGE	C32	ICTMR	ICI<1:0>	ICOV	ICBNE	ICM<2:0>	0000			
2810	IC5BUF	31:16	IC5BUF<31:0>															xxxx	
		15:0																xxxx	

**Legend:** x = unknown value on Reset; — = unimplemented, read as '0'. Reset values are shown in hexadecimal.

**Note 1:** This register has corresponding CLR, SET and INV registers at its virtual address, plus an offset of 0x4, 0x8 and 0xC, respectively. See **Section 12.1.1 “CLR, SET and INV Registers”** for more information.

TABLE 4-10: OUTPUT COMPARE 1-OUTPUT COMPARE 5 REGISTER MAP<sup>(1)</sup>

Virtual Address (BF80_#)	Register Name	Bit Range	Bits															All Resets	
			31/15	30/14	29/13	28/12	27/11	26/10	25/9	24/8	23/7	22/6	21/5	20/4	19/3	18/2	17/1		16/0
3000	OC1CON	31:16	—	—	—	—	—	—	—	—	—	—	—	—	—	—	—	—	0000
		15:0	ON	FRZ	SIDL	—	—	—	—	—	—	—	—	OC32	OCFLT	OCTSEL	OCM<2:0>		0000
3010	OC1R	31:16	OC1R<31:0>															xxxx	
		15:0																xxxx	
3020	OC1RS	31:16	OC1RS<31:0>															xxxx	
		15:0																xxxx	
3200	OC2CON	31:16	—	—	—	—	—	—	—	—	—	—	—	—	—	—	—	—	0000
		15:0	ON	FRZ	SIDL	—	—	—	—	—	—	—	—	OC32	OCFLT	OCTSEL	OCM<2:0>		0000
3210	OC2R	31:16	OC2R<31:0>															xxxx	
		15:0																xxxx	
3220	OC2RS	31:16	OC2RS<31:0>															xxxx	
		15:0																xxxx	
3400	OC3CON	31:16	—	—	—	—	—	—	—	—	—	—	—	—	—	—	—	—	0000
		15:0	ON	FRZ	SIDL	—	—	—	—	—	—	—	—	OC32	OCFLT	OCTSEL	OCM<2:0>		0000
3410	OC3R	31:16	OC3R<31:0>															xxxx	
		15:0																xxxx	
3420	OC3RS	31:16	OC3RS<31:0>															xxxx	
		15:0																xxxx	
3600	OC4CON	31:16	—	—	—	—	—	—	—	—	—	—	—	—	—	—	—	—	0000
		15:0	ON	FRZ	SIDL	—	—	—	—	—	—	—	—	OC32	OCFLT	OCTSEL	OCM<2:0>		0000
3610	OC4R	31:16	OC4R<31:0>															xxxx	
		15:0																xxxx	
3620	OC4RS	31:16	OC4RS<31:0>															xxxx	
		15:0																xxxx	
3800	OC5CON	31:16	—	—	—	—	—	—	—	—	—	—	—	—	—	—	—	—	0000
		15:0	ON	FRZ	SIDL	—	—	—	—	—	—	—	—	OC32	OCFLT	OCTSEL	OCM<2:0>		0000
3810	OC5R	31:16	OC5R<31:0>															xxxx	
		15:0																xxxx	
3820	OC5RS	31:16	OC5RS<31:0>															xxxx	
		15:0																xxxx	

**Legend:** x = unknown value on Reset; — = unimplemented, read as '0'. Reset values are shown in hexadecimal.

**Note 1:** All registers in this table have corresponding CLR, SET and INV registers at their virtual addresses, plus offsets of 0x4, 0x8 and 0xC, respectively. See Section 12.1.1 "CLR, SET and INV Registers" for more information.

TABLE 4-11: I2C1, I2C1A, I2C2A AND I2C3A REGISTER MAP<sup>(1)</sup>

Virtual Address (BF80_#)	Register Name	Bit Range	Bits															All Resets	
			31/15	30/14	29/13	28/12	27/11	26/10	25/9	24/8	23/7	22/6	21/5	20/4	19/3	18/2	17/1		16/0
5000	I2C1ACON	31:16	—	—	—	—	—	—	—	—	—	—	—	—	—	—	—	—	0000
		15:0	ON	FRZ	SIDL	SCLREL	STRICT	A10M	DISSLW	SMEN	GCEN	STREN	ACKDT	ACKEN	RCEN	PEN	RSEN	SEN	0000
5010	I2C1ASTAT	31:16	—	—	—	—	—	—	—	—	—	—	—	—	—	—	—	—	0000
		15:0	ACKSTAT	TRSTAT	—	—	—	BCL	GCSTAT	ADD10	IWCOL	I2COV	D/A	P	S	R/W	RBF	TBF	0000
5020	I2C1AADD	31:16	—	—	—	—	—	—	—	—	—	—	—	—	—	—	—	—	0000
		15:0	—	—	—	—	—	—	—	—	—	—	—	—	—	—	—	—	0000
5030	I2C1AMSK	31:16	—	—	—	—	—	—	—	—	—	—	—	—	—	—	—	—	0000
		15:0	—	—	—	—	—	—	—	—	—	—	—	—	—	—	—	—	0000
5040	I2C1ABRG	31:16	—	—	—	—	—	—	—	—	—	—	—	—	—	—	—	—	0000
		15:0	—	—	—	—	—	—	—	—	—	—	—	—	—	—	—	—	0000
5050	I2C1ATRN	31:16	—	—	—	—	—	—	—	—	—	—	—	—	—	—	—	—	0000
		15:0	—	—	—	—	—	—	—	—	—	—	—	—	—	—	—	—	0000
5060	I2C1ARCV	31:16	—	—	—	—	—	—	—	—	—	—	—	—	—	—	—	—	0000
		15:0	—	—	—	—	—	—	—	—	—	—	—	—	—	—	—	—	0000
5100	I2C2ACON	31:16	—	—	—	—	—	—	—	—	—	—	—	—	—	—	—	—	0000
		15:0	ON	FRZ	SIDL	SCLREL	STRICT	A10M	DISSLW	SMEN	GCEN	STREN	ACKDT	ACKEN	RCEN	PEN	RSEN	SEN	0000
5110	I2C2ASTAT	31:16	—	—	—	—	—	—	—	—	—	—	—	—	—	—	—	—	0000
		15:0	ACKSTAT	TRSTAT	—	—	—	BCL	GCSTAT	ADD10	IWCOL	I2COV	D/A	P	S	R/W	RBF	TBF	0000
5120	I2C2AADD	31:16	—	—	—	—	—	—	—	—	—	—	—	—	—	—	—	—	0000
		15:0	—	—	—	—	—	—	—	—	—	—	—	—	—	—	—	—	0000
5130	I2C2AMSK	31:16	—	—	—	—	—	—	—	—	—	—	—	—	—	—	—	—	0000
		15:0	—	—	—	—	—	—	—	—	—	—	—	—	—	—	—	—	0000
5140	I2C2ABRG	31:16	—	—	—	—	—	—	—	—	—	—	—	—	—	—	—	—	0000
		15:0	—	—	—	—	—	—	—	—	—	—	—	—	—	—	—	—	0000
5150	I2C2ATRN	31:16	—	—	—	—	—	—	—	—	—	—	—	—	—	—	—	—	0000
		15:0	—	—	—	—	—	—	—	—	—	—	—	—	—	—	—	—	0000
5160	I2C2ARCV	31:16	—	—	—	—	—	—	—	—	—	—	—	—	—	—	—	—	0000
		15:0	—	—	—	—	—	—	—	—	—	—	—	—	—	—	—	—	0000
5200	I2C3ACON	31:16	—	—	—	—	—	—	—	—	—	—	—	—	—	—	—	—	0000
		15:0	ON	FRZ	SIDL	SCLREL	STRICT	A10M	DISSLW	SMEN	GCEN	STREN	ACKDT	ACKEN	RCEN	PEN	RSEN	SEN	0000
5210	I2C3ASTAT	31:16	—	—	—	—	—	—	—	—	—	—	—	—	—	—	—	—	0000
		15:0	ACKSTAT	TRSTAT	—	—	—	BCL	GCSTAT	ADD10	IWCOL	I2COV	D/A	P	S	R/W	RBF	TBF	0000

**Legend:** x = unknown value on Reset; — = unimplemented, read as '0'. Reset values are shown in hexadecimal.

**Note 1:** All registers in this table except I2CxRCV have corresponding CLR, SET and INV registers at their virtual addresses, plus offsets of 0x4, 0x8 and 0xC, respectively. See Section 12.1.1 "CLR, SET and INV Registers" for more information.

TABLE 4-11: I2C1, I2C1A, I2C2A AND I2C3A REGISTER MAP<sup>(1)</sup> (CONTINUED)

Virtual Address (BF80_#)	Register Name	Bit Range	Bits																All Resets
			31/15	30/14	29/13	28/12	27/11	26/10	25/9	24/8	23/7	22/6	21/5	20/4	19/3	18/2	17/1	16/0	
5220	I2C3AADD	31:16	—	—	—	—	—	—	—	—	—	—	—	—	—	—	—	—	0000
		15:0	—	—	—	—	—	—	ADD<9:0>										
5230	I2C3AMSK	31:16	—	—	—	—	—	—	—	—	—	—	—	—	—	—	—	—	0000
		15:0	—	—	—	—	—	—	MSK<9:0>										
5240	I2C3ABRG	31:16	—	—	—	—	—	—	—	—	—	—	—	—	—	—	—	—	0000
		15:0	—	—	—	—	—	I2C3ABRG<11:0>											0000
5250	I2C3ATRN	31:16	—	—	—	—	—	—	—	—	—	—	—	—	—	—	—	—	0000
		15:0	—	—	—	—	—	—	I2CT3ADATA<7:0>										
5260	I2C3ARCV	31:16	—	—	—	—	—	—	—	—	—	—	—	—	—	—	—	—	0000
		15:0	—	—	—	—	—	—	I2CR3ADATA<7:0>										
5300	I2C1CON	31:16	—	—	—	—	—	—	—	—	—	—	—	—	—	—	—	—	0000
		15:0	ON	FRZ	SIDL	SCLREL	STRICT	A10M	DISSLW	SMEN	GCEN	STREN	ACKDT	ACKEN	RCEN	PEN	RSEN	SEN	0000
5310	I2C1STAT	31:16	—	—	—	—	—	—	—	—	—	—	—	—	—	—	—	—	0000
		15:0	ACKSTAT	TRSTAT	—	—	—	BCL	GCSTAT	ADD10	IWCOL	I2COV	D/A	P	S	R/W	RBF	TBF	0000
5320	I2C1ADD	31:16	—	—	—	—	—	—	—	—	—	—	—	—	—	—	—	—	0000
		15:0	—	—	—	—	—	—	ADD<9:0>										
5330	I2C1MSK	31:16	—	—	—	—	—	—	—	—	—	—	—	—	—	—	—	—	0000
		15:0	—	—	—	—	—	—	MSK<9:0>										
5340	I2C1BRG	31:16	—	—	—	—	—	—	—	—	—	—	—	—	—	—	—	—	0000
		15:0	—	—	—	—	—	I2C1BRG<11:0>											0000
5350	I2C1TRN	31:16	—	—	—	—	—	—	—	—	—	—	—	—	—	—	—	—	0000
		15:0	—	—	—	—	—	—	I2CT1DATA<7:0>										
5360	I2C1RCV	31:16	—	—	—	—	—	—	—	—	—	—	—	—	—	—	—	—	0000
		15:0	—	—	—	—	—	—	I2CR1DATA<7:0>										

**Legend:** x = unknown value on Reset; — = unimplemented, read as '0'. Reset values are shown in hexadecimal.

**Note 1:** All registers in this table except I2CxRCV have corresponding CLR, SET and INV registers at their virtual addresses, plus offsets of 0x4, 0x8 and 0xC, respectively. See **Section 12.1.1 “CLR, SET and INV Registers”** for more information.

**TABLE 4-12: I2C2 REGISTER MAP FOR PIC32MX575F256L, PIC32MX575F512L, PIC32MX675F256L, PIC32MX675F512L, PIC32MX695F512L, PIC32MX775F256L, PIC32MX775F512L AND PIC32MX795F512L DEVICES<sup>(1)</sup>**

Virtual Address (BF80_#)	Register Name	Bit Range	Bits																All Resets
			31/15	30/14	29/13	28/12	27/11	26/10	25/9	24/8	23/7	22/6	21/5	20/4	19/3	18/2	17/1	16/0	
5400	I2C2CON	31:16	—	—	—	—	—	—	—	—	—	—	—	—	—	—	—	—	0000
		15:0	ON	FRZ	SIDL	SCLREL	STRICT	A10M	DISSLW	SMEN	GCEN	STREN	ACKDT	ACKEN	RCEN	PEN	RSEN	SEN	0000
5410	I2C2STAT	31:16	—	—	—	—	—	—	—	—	—	—	—	—	—	—	—	—	0000
		15:0	ACKSTAT	TRSTAT	—	—	—	BCL	GCSTAT	ADD10	IWCOL	I2COV	D/A	P	S	R/W	RBF	TBF	0000
5420	I2C2ADD	31:16	—	—	—	—	—	—	—	—	—	—	—	—	—	—	—	—	0000
		15:0	—	—	—	—	—	—	ADD<9:0>										0000
5430	I2C2MSK	31:16	—	—	—	—	—	—	—	—	—	—	—	—	—	—	—	—	0000
		15:0	—	—	—	—	—	—	MSK<9:0>										0000
5440	I2C2BRG	31:16	—	—	—	—	—	—	—	—	—	—	—	—	—	—	—	—	0000
		15:0	—	—	—	—	—	—	I2C2BRG<11:0>										0000
5450	I2C2TRN	31:16	—	—	—	—	—	—	—	—	—	—	—	—	—	—	—	—	0000
		15:0	—	—	—	—	—	—	I2CT1DATA<7:0>										0000
5460	I2C2RCV	31:16	—	—	—	—	—	—	—	—	—	—	—	—	—	—	—	—	0000
		15:0	—	—	—	—	—	—	I2CR1DATA<7:0>										0000

**Legend:** x = unknown value on Reset; — = unimplemented, read as '0'. Reset values are shown in hexadecimal.

**Note 1:** All registers in this table except I2CxRCV have corresponding CLR, SET and INV registers at their virtual addresses, plus offsets of 0x4, 0x8 and 0xC, respectively. See **Section 12.1.1 "CLR, SET and INV Registers"** for more information.

TABLE 4-13: UART1A, UART1B, UART2A, UART2B, UART3A AND UART3B REGISTER MAP

Virtual Address (BF80_#)	Register Name	Bit Range	Bits															All Resets
			31/15	30/14	29/13	28/12	27/11	26/10	25/9	24/8	23/7	22/6	21/5	20/4	19/3	18/2	17/1	
6000	U1AMODE <sup>(1)</sup>	31:16	—	—	—	—	—	—	—	—	—	—	—	—	—	—	—	0000
		15:0	ON	FRZ	SIDL	IREN	RTSMD	—	UEN<1:0>	WAKE	LPBACK	ABAUD	RXINV	BRGH	PDSEL<1:0>	STSEL	0000	
6010	U1ASTA <sup>(1)</sup>	31:16	—	—	—	—	—	—	ADM_EN	ADDR<7:0>								0000
		15:0	UTXISEL<1:0>	UTXINV	URXEN	UTXBRK	UTXEN	UTXBF	TRMT	URXISEL<1:0>	ADDEN	RIDLE	PERR	FERR	OERR	URXDA	0110	
6020	U1ATXREG	31:16	—	—	—	—	—	—	—	—	—	—	—	—	—	—	0000	
		15:0	—	—	—	—	—	—	TX8	Transmit Register								0000
6030	U1ARXREG	31:16	—	—	—	—	—	—	—	—	—	—	—	—	—	—	0000	
		15:0	—	—	—	—	—	—	RX8	Receive Register								0000
6040	U1ABRG <sup>(1)</sup>	31:16	—	—	—	—	—	—	—	—	—	—	—	—	—	—	0000	
		15:0	BRG<15:0>															0000
6200	U1BMODE <sup>(1)</sup>	31:16	—	—	—	—	—	—	—	—	—	—	—	—	—	—	0000	
		15:0	ON	FRZ	SIDL	IREN	—	—	—	WAKE	LPBACK	ABAUD	RXINV	BRGH	PDSEL<1:0>	STSEL	0000	
6210	U1BSTA <sup>(1)</sup>	31:16	—	—	—	—	—	—	ADM_EN	ADDR<7:0>								0000
		15:0	UTXISEL<1:0>	UTXINV	URXEN	UTXBRK	UTXEN	UTXBF	TRMT	URXISEL<1:0>	ADDEN	RIDLE	PERR	FERR	OERR	URXDA	0110	
6220	U1BTXREG	31:16	—	—	—	—	—	—	—	—	—	—	—	—	—	—	0000	
		15:0	—	—	—	—	—	—	TX8	Transmit Register								0000
6230	U1BRXREG	31:16	—	—	—	—	—	—	—	—	—	—	—	—	—	—	0000	
		15:0	—	—	—	—	—	—	RX8	Receive Register								0000
6240	U1BBRG <sup>(1)</sup>	31:16	—	—	—	—	—	—	—	—	—	—	—	—	—	—	0000	
		15:0	BRG<15:0>															0000
6400	U2AMODE <sup>(1)</sup>	31:16	—	—	—	—	—	—	—	—	—	—	—	—	—	—	0000	
		15:0	ON	FRZ	SIDL	IREN	RTSMD	—	UEN<1:0>	WAKE	LPBACK	ABAUD	RXINV	BRGH	PDSEL<1:0>	STSEL	0000	
6410	U2ASTA <sup>(1)</sup>	31:16	—	—	—	—	—	—	ADM_EN	ADDR<7:0>								0000
		15:0	UTXISEL<1:0>	UTXINV	URXEN	UTXBRK	UTXEN	UTXBF	TRMT	URXISEL<1:0>	ADDEN	RIDLE	PERR	FERR	OERR	URXDA	0110	
6420	U2ATXREG	31:16	—	—	—	—	—	—	—	—	—	—	—	—	—	—	0000	
		15:0	—	—	—	—	—	—	TX8	Transmit Register								0000
6430	U2ARXREG	31:16	—	—	—	—	—	—	—	—	—	—	—	—	—	—	0000	
		15:0	—	—	—	—	—	—	RX8	Receive Register								0000
6440	U2ABRG <sup>(1)</sup>	31:16	—	—	—	—	—	—	—	—	—	—	—	—	—	—	0000	
		15:0	BRG<15:0>															0000
6600	U2BMODE <sup>(1)</sup>	31:16	—	—	—	—	—	—	—	—	—	—	—	—	—	—	0000	
		15:0	ON	FRZ	SIDL	IREN	—	—	—	WAKE	LPBACK	ABAUD	RXINV	BRGH	PDSEL<1:0>	STSEL	0000	
6610	U2BSTA <sup>(1)</sup>	31:16	—	—	—	—	—	—	ADM_EN	ADDR<7:0>								0000
		15:0	UTXISEL<1:0>	UTXINV	URXEN	UTXBRK	UTXEN	UTXBF	TRMT	URXISEL<1:0>	ADDEN	RIDLE	PERR	FERR	OERR	URXDA	0110	
6620	U2BTXREG	31:16	—	—	—	—	—	—	—	—	—	—	—	—	—	—	0000	
		15:0	—	—	—	—	—	—	TX8	Transmit Register								0000

**Legend:** x = unknown value on Reset; — = unimplemented, read as '0'. Reset values are shown in hexadecimal.

**Note 1:** This register has corresponding CLR, SET and INV registers at its virtual address, plus an offset of 0x4, 0x8 and 0xC, respectively. See Section 12.1.1 "CLR, SET and INV Registers" for more information.

**TABLE 4-13: UART1A, UART1B, UART2A, UART2B, UART3A AND UART3B REGISTER MAP (CONTINUED)**

Virtual Address (BF80_#)	Register Name	Bit Range	Bits														All Resets		
			31/15	30/14	29/13	28/12	27/11	26/10	25/9	24/8	23/7	22/6	21/5	20/4	19/3	18/2		17/1	16/0
6630	U2BRXREG	31:16	—	—	—	—	—	—	—	—	—	—	—	—	—	—	—	—	0000
		15:0	—	—	—	—	—	—	—	RX8	Receive Register								0000
6640	U2BBRG <sup>(1)</sup>	31:16	—	—	—	—	—	—	—	—	—	—	—	—	—	—	—	0000	
		15:0	BRG<15:0>														0000		
6800	U3AMODE <sup>(1)</sup>	31:16	—	—	—	—	—	—	—	—	—	—	—	—	—	—	—	0000	
		15:0	ON	FRZ	SIDL	IREN	RTSMO	—	UEN<1:0>		WAKE	LPBACK	ABAUD	RXINV	BRGH	PDSSEL<1:0>		STSEL	0000
6810	U3ASTA <sup>(1)</sup>	31:16	—	—	—	—	—	—	—	—	—	—	—	—	—	—	—	0000	
		15:0	UTXISEL<1:0>		UTXINV	URXEN	UTXBRK	UTXEN	UTXBF	TRMT	URXISEL<1:0>		ADDEN	RIDL	PERR	FERR	OERR	URXDA	0110
6820	U3ATXREG	31:16	—	—	—	—	—	—	—	—	—	—	—	—	—	—	—	0000	
		15:0	—	—	—	—	—	—	—	TX8	Transmit Register								0000
6830	U3ARXREG	31:16	—	—	—	—	—	—	—	—	—	—	—	—	—	—	—	0000	
		15:0	—	—	—	—	—	—	—	RX8	Receive Register								0000
6840	U3ABRG <sup>(1)</sup>	31:16	—	—	—	—	—	—	—	—	—	—	—	—	—	—	—	0000	
		15:0	BRG<15:0>														0000		
6A00	U3BMODE <sup>(1)</sup>	31:16	—	—	—	—	—	—	—	—	—	—	—	—	—	—	—	0000	
		15:0	ON	FRZ	SIDL	IREN	—	—	—	—	WAKE	LPBACK	ABAUD	RXINV	BRGH	PDSSEL<1:0>		STSEL	0000
6A10	U3BSTA <sup>(1)</sup>	31:16	—	—	—	—	—	—	—	—	—	—	—	—	—	—	—	0000	
		15:0	UTXISEL<1:0>		UTXINV	URXEN	UTXBRK	UTXEN	UTXBF	TRMT	URXISEL<1:0>		ADDEN	RIDL	PERR	FERR	OERR	URXDA	0110
6A20	U3BTXREG	31:16	—	—	—	—	—	—	—	—	—	—	—	—	—	—	—	0000	
		15:0	—	—	—	—	—	—	—	TX8	Transmit Register								0000
6A30	U3BRXREG	31:16	—	—	—	—	—	—	—	—	—	—	—	—	—	—	—	0000	
		15:0	—	—	—	—	—	—	—	RX8	Receive Register								0000
6A40	U3BBRG <sup>(1)</sup>	31:16	—	—	—	—	—	—	—	—	—	—	—	—	—	—	—	0000	
		15:0	BRG<15:0>														0000		

**Legend:** x = unknown value on Reset; — = unimplemented, read as '0'. Reset values are shown in hexadecimal.

**Note 1:** This register has corresponding CLR, SET and INV registers at its virtual address, plus an offset of 0x4, 0x8 and 0xC, respectively. See Section 12.1.1 "CLR, SET and INV Registers" for more information.

**TABLE 4-14: SPI1A, SPI2A AND SPI3A REGISTER MAP<sup>(1)</sup>**

Virtual Address (BF80_#)	Register Name	Bit Range	Bits															All Resets		
			31/15	30/14	29/13	28/12	27/11	26/10	25/9	24/8	23/7	22/6	21/5	20/4	19/3	18/2	17/1		16/0	
5800	SPI1ACON	31:16	FRMEN	FRMSYNC	FRMPOL	MSEN	FRMSYPW	FRMCNT<2:0>		—	—	—	—	—	—	—	SPIFE	ENHBUF	0000	
		15:0	ON	FRZ	SIDL	DISSDO	MODE32	MODE16	SMP	CKE	SSEN	CKP	MSTEN	—	—	STXISEL<1:0>	—	SRXISEL<1:0>	0000	
5810	SPI1ASTAT	31:16	—	—	—	RXBUFELM<4:0>				—	—	—	TXBUFELM<4:0>				0000			
		15:0	—	—	—	—	SPIBUSY	—	—	SPITUR	SRMT	SPIROV	SPIRBE	—	SPITBE	—	SPITBF	SPIRBF	0000	
5820	SPI1ABUF	31:16	DATA<31:0>															0000		
		15:0	DATA<31:0>															0000		
5830	SPI1ABRG	31:16	—	—	—	—	—	—	—	—	—	—	—	—	—	—	—	—	—	0000
		15:0	—	—	—	—	—	—	—	—	—	—	—	—	—	—	—	—	—	—
5A00	SPI2ACON	31:16	FRMEN	FRMSYNC	FRMPOL	MSEN	FRMSYPW	FRMCNT<2:0>		—	—	—	—	—	—	—	SPIFE	ENHBUF	0000	
		15:0	ON	FRZ	SIDL	DISSDO	MODE32	MODE16	SMP	CKE	SSEN	CKP	MSTEN	—	—	STXISEL<1:0>	—	SRXISEL<1:0>	0000	
5A10	SPI2ASTAT	31:16	—	—	—	RXBUFELM<4:0>				—	—	—	TXBUFELM<4:0>				0000			
		15:0	—	—	—	—	SPIBUSY	—	—	SPITUR	SRMT	SPIROV	SPIRBE	—	SPITBE	—	SPITBF	SPIRBF	0000	
5A20	SPI2ABUF	31:16	DATA<31:0>															0000		
		15:0	DATA<31:0>															0000		
5A30	SPI2ABRG	31:16	—	—	—	—	—	—	—	—	—	—	—	—	—	—	—	—	—	0000
		15:0	—	—	—	—	—	—	—	—	—	—	—	—	—	—	—	—	—	—
5C00	SPI3ACON	31:16	FRMEN	FRMSYNC	FRMPOL	MSEN	FRMSYPW	FRMCNT<2:0>		—	—	—	—	—	—	—	SPIFE	ENHBUF	0000	
		15:0	ON	FRZ	SIDL	DISSDO	MODE32	MODE16	SMP	CKE	SSEN	CKP	MSTEN	—	—	STXISEL<1:0>	—	SRXISEL<1:0>	0000	
5C10	SPI3ASTAT	31:16	—	—	—	RXBUFELM<4:0>				—	—	—	TXBUFELM<4:0>				0000			
		15:0	—	—	—	—	SPIBUSY	—	—	SPITUR	SRMT	SPIROV	SPIRBE	—	SPITBE	—	SPITBF	SPIRBF	0000	
5C20	SPI3ABUF	31:16	DATA<31:0>															0000		
		15:0	DATA<31:0>															0000		
5C30	SPI3ABRG	31:16	—	—	—	—	—	—	—	—	—	—	—	—	—	—	—	—	—	0000
		15:0	—	—	—	—	—	—	—	—	—	—	—	—	—	—	—	—	—	—

**Legend:** x = unknown value on Reset; — = unimplemented, read as '0'. Reset values are shown in hexadecimal.

**Note 1:** All registers in this table except SPIxBUF have corresponding CLR, SET and INV registers at their virtual addresses, plus offsets of 0x4, 0x8 and 0xC, respectively. See Section 12.1.1 "CLR, SET and INV Registers" for more information.



**TABLE 4-15: SPI1 REGISTER MAP FOR PIC32MX575F256L, PIC32MX575F512L, PIC32MX675F256L, PIC32MX675F512L, PIC32MX695F512L, PIC32MX775F256L, PIC32MX775F512L AND PIC32MX795F512L DEVICES<sup>(1)</sup>**

Virtual Address (BF80_#)	Register Name	Bit Range	Bits														All Resets		
			31/15	30/14	29/13	28/12	27/11	26/10	25/9	24/8	23/7	22/6	21/5	20/4	19/3	18/2		17/1	16/0
5E00	SPI1CON	31:16	FRMEN	FRMSYNC	FRMPOL	MSEN	FRMSYPW	FRMCNT<2:0>			—	—	—	—	—	—	SPIFE	ENHBUF	0000
		15:0	ON	FRZ	SIDL	DISSDO	MODE32	MODE16	SMP	CKE	SSEN	CKP	MSTEN	—	STXISEL<1:0>		SRXISEL<1:0>		0000
5E10	SPI1STAT	31:16	—				RXBUFELM<4:0>				—	—	—	TXBUFELM<4:0>				0000	
		15:0	—	—	—	—	SPIBUSY	—	—	SPITUR	SRMT	SPIROV	SPIRBE	—	SPITBE	—	SPITBF	SPIRBF	0000
5E20	SPI1BUF	31:16	DATA<31:0>														0000		
		15:0	DATA<31:0>														0000		
5E30	SPI1BRG	31:16	—	—	—	—	—	—	—	—	—	—	—	—	—	—	—	—	0000
		15:0	—	—	—	—	—	—	—	—	BRG<8:0>								0000

**Legend:** x = unknown value on Reset; — = unimplemented, read as '0'. Reset values are shown in hexadecimal.

**Note 1:** All registers in this table except SPIxBUF have corresponding CLR, SET and INV registers at their virtual addresses, plus offsets of 0x4, 0x8 and 0xC, respectively. See **Section 12.1.1 “CLR, SET and INV Registers”** for more information.

TABLE 4-16: ADC REGISTER MAP

Virtual Address (BF80_#)	Register Name	Bit Range	Bits															All Resets	
			31/15	30/14	29/13	28/12	27/11	26/10	25/9	24/8	23/7	22/6	21/5	20/4	19/3	18/2	17/1		16/0
9000	AD1CON1 <sup>(1)</sup>	31:16	—	—	—	—	—	—	—	—	—	—	—	—	—	—	—	—	0000
		15:0	ON	FRZ	SIDL	—	—	FORM<2:0>			SSRC<2:0>			CLRASAM	—	ASAM	SAMP	DONE	0000
9010	AD1CON2 <sup>(1)</sup>	31:16	—	—	—	—	—	—	—	—	—	—	—	—	—	—	—	—	0000
		15:0	VCFG2	VCFG1	VCFG0	OFFCAL	—	CSCNA	—	—	BUFS	—	SMPI<3:0>			—	—	—	—
9020	AD1CON3 <sup>(1)</sup>	31:16	—	—	—	—	—	—	—	—	—	—	—	—	—	—	—	—	0000
		15:0	ADRC	—	—	SAMC<4:0>				ADCS<7:0>							—	—	—
9040	AD1CHS <sup>(1)</sup>	31:16	CH0NB	—	—	CH0SB<3:0>				CH0NA	—	—	—	CH0SA<3:0>				0000	
		15:0	—	—	—	—	—	—	—	—	—	—	—	—	—	—	—	—	—
9060	AD1PCFG <sup>(1)</sup>	31:16	—	—	—	—	—	—	—	—	—	—	—	—	—	—	—	—	0000
		15:0	PCFG15	PCFG14	PCFG13	PCFG12	PCFG11	PCFG10	PCFG9	PCFG8	PCFG7	PCFG6	PCFG5	PCFG4	PCFG3	PCFG2	PCFG1	PCFG0	0000
9050	AD1CSSL <sup>(1)</sup>	31:16	—	—	—	—	—	—	—	—	—	—	—	—	—	—	—	—	0000
		15:0	CSSL15	CSSL14	CSSL13	CSSL12	CSSL11	CSSL10	CSSL9	CSSL8	CSSL7	CSSL6	CSSL5	CSSL4	CSSL3	CSSL2	CSSL1	CSSL0	0000
9070	ADC1BUF0	31:16	ADC Result Word 0 (ADC1BUF0<31:0>)															0000	
		15:0																0000	
9080	ADC1BUF1	31:16	ADC Result Word 1 (ADC1BUF1<31:0>)															0000	
		15:0																0000	
9090	ADC1BUF2	31:16	ADC Result Word 2 (ADC1BUF2<31:0>)															0000	
		15:0																0000	
90A0	ADC1BUF3	31:16	ADC Result Word 3 (ADC1BUF3<31:0>)															0000	
		15:0																0000	
90B0	ADC1BUF4	31:16	ADC Result Word 4 (ADC1BUF4<31:0>)															0000	
		15:0																0000	
90C0	ADC1BUF5	31:16	ADC Result Word 5 (ADC1BUF5<31:0>)															0000	
		15:0																0000	
90D0	ADC1BUF6	31:16	ADC Result Word 6 (ADC1BUF6<31:0>)															0000	
		15:0																0000	
90E0	ADC1BUF7	31:16	ADC Result Word 7 (ADC1BUF7<31:0>)															0000	
		15:0																0000	
90F0	ADC1BUF8	31:16	ADC Result Word 8 (ADC1BUF8<31:0>)															0000	
		15:0																0000	
9100	ADC1BUF9	31:16	ADC Result Word 9 (ADC1BUF9<31:0>)															0000	
		15:0																0000	
9110	ADC1BUFA	31:16	ADC Result Word A (ADC1BUFA<31:0>)															0000	
		15:0																0000	
9120	ADC1BUFB	31:16	ADC Result Word B (ADC1BUFB<31:0>)															0000	
		15:0																0000	

**Legend:** x = unknown value on Reset; — = unimplemented, read as '0'. Reset values are shown in hexadecimal.

**Note 1:** This register has corresponding CLR, SET and INV registers at their virtual addresses, plus offsets of 0x4, 0x8 and 0xC, respectively. See Section 12.1.1 "CLR, SET and INV Registers" for more information.

**TABLE 4-16: ADC REGISTER MAP (CONTINUED)**

Virtual Address (BF80_#)	Register Name	Bit Range	Bits														All Resets
			31/15	30/14	29/13	28/12	27/11	26/10	25/9	24/8	23/7	22/6	21/5	20/4	19/3	18/2	
9130	ADC1BUFC	31:16	ADC Result Word C (ADC1BUFC<31:0>)														0000
		15:0															0000
9140	ADC1BUFD	31:16	ADC Result Word D (ADC1BUFD<31:0>)														0000
		15:0															0000
9150	ADC1BUFE	31:16	ADC Result Word E (ADC1BUFE<31:0>)														0000
		15:0															0000
9160	ADC1BUFF	31:16	ADC Result Word F (ADC1BUFF<31:0>)														0000
		15:0															0000

**Legend:** x = unknown value on Reset; — = unimplemented, read as '0'. Reset values are shown in hexadecimal.

**Note 1:** This register has corresponding CLR, SET and INV registers at their virtual addresses, plus offsets of 0x4, 0x8 and 0xC, respectively. See Section 12.1.1 “CLR, SET and INV Registers” for more information.

TABLE 4-17: DMA GLOBAL REGISTER MAP

Virtual Address (BF88_#)	Register Name	Bit Range	Bits														All Resets		
			31/15	30/14	29/13	28/12	27/11	26/10	25/9	24/8	23/7	22/6	21/5	20/4	19/3	18/2		17/1	16/0
3000	DMACON <sup>(1)</sup>	31:16	—	—	—	—	—	—	—	—	—	—	—	—	—	—	—	—	0000
		15:0	ON	FRZ	SIDL	SUSPEND	DMABUSY	—	—	—	—	—	—	—	—	—	—	—	0000
3010	DMASTAT	31:16	—	—	—	—	—	—	—	—	—	—	—	—	—	—	—	—	0000
		15:0	—	—	—	—	—	—	—	—	—	—	—	—	RDWR	DMACH<2:0>			0000
3020	DMAADDR	31:16	DMAADDR<31:0>														0000		
		15:0															0000		

**Legend:** x = unknown value on Reset; — = unimplemented, read as '0'. Reset values are shown in hexadecimal.

**Note 1:** This register has corresponding CLR, SET and INV registers at its virtual address, plus an offset of 0x4, 0x8 and 0xC, respectively. See Section 12.1.1 “CLR, SET and INV Registers” for more information.

TABLE 4-18: DMA CRC REGISTER MAP<sup>(1)</sup>

Virtual Address (BF88_#)	Register Name	Bit Range	Bits														All Resets		
			31/15	30/14	29/13	28/12	27/11	26/10	25/9	24/8	23/7	22/6	21/5	20/4	19/3	18/2		17/1	16/0
3030	DCRCCON	31:16	—	—	BYTO<1:0>		WBO	—	—	BITO	—	—	—	—	—	—	—	—	0000
		15:0	—	—	—	PLEN<4:0>				CRcen	CRcAPP	CRcTYP	—	—	CRcCH<2:0>			0000	
3040	DCRCDATA	31:16	DCRCDATA<31:0>														0000		
		15:0															0000		
3050	DCRCXOR	31:16	DCRCXOR<31:0>														0000		
		15:0															0000		

**Legend:** x = unknown value on Reset; — = unimplemented, read as '0'. Reset values are shown in hexadecimal.

**Note 1:** All registers in this table have corresponding CLR, SET and INV registers at their virtual addresses, plus offsets of 0x4, 0x8 and 0xC, respectively. See Section 12.1.1 “CLR, SET and INV Registers” for more information.

**TABLE 4-19: DMA CHANNELS 0-7 REGISTER MAP<sup>(1)</sup>**

Virtual Address (BF88_#)	Register Name	Bit Range	Bits															All Resets
			31/15	30/14	29/13	28/12	27/11	26/10	25/9	24/8	23/7	22/6	21/5	20/4	19/3	18/2	17/1	
3060	DCH0CON	31:16	—	—	—	—	—	—	—	—	—	—	—	—	—	—	—	0000
		15:0	CHBUSY	—	—	—	—	—	—	CHCHNS	CHEN	CHAED	CHCHN	CHAEN	—	CHEDET	CHPRI<1:0>	0000
3070	DCH0ECON	31:16	—	—	—	—	—	—	—	CHAIRQ<7:0>							00FF	
		15:0	CHSIRQ<7:0>							CFORCE	CABORT	PATEN	SIRQEN	AIRQEN	—	—	—	FF00
3080	DCH0INT	31:16	—	—	—	—	—	—	—	CHSDIE	CHSHIE	CHDDIE	CHDHIE	CHBCIE	CHCCIE	CHTAIE	CHERIE	0000
		15:0	—	—	—	—	—	—	—	CHSDIF	CHSHIF	CHDDIF	CHDHIF	CHBCIF	CHCCIF	CHTAIF	CHERIF	0000
3090	DCH0SSA	31:16	CHSSA<31:0>															0000
		15:0																0000
30A0	DCH0DSA	31:16	CHDSA<31:0>															0000
		15:0																0000
30B0	DCH0SSIZ	31:16	—	—	—	—	—	—	—	—	—	—	—	—	—	—	—	0000
		15:0	CHSSIZ<15:0>															0000
30C0	DCH0DSIZ	31:16	—	—	—	—	—	—	—	—	—	—	—	—	—	—	—	0000
		15:0	CHDSIZ<15:0>															0000
30D0	DCH0SPTR	31:16	—	—	—	—	—	—	—	—	—	—	—	—	—	—	—	0000
		15:0	CHSPTR<15:0>															0000
30E0	DCH0DPTR	31:16	—	—	—	—	—	—	—	—	—	—	—	—	—	—	—	0000
		15:0	CHDPTR<15:0>															0000
30F0	DCH0CSIZ	31:16	—	—	—	—	—	—	—	—	—	—	—	—	—	—	—	0000
		15:0	CHCSIZ<15:0>															0000
3100	DCH0CPTR	31:16	—	—	—	—	—	—	—	—	—	—	—	—	—	—	—	0000
		15:0	CHCPTR<15:0>															0000
3110	DCH0DAT	31:16	—	—	—	—	—	—	—	—	—	—	—	—	—	—	—	0000
		15:0	—	—	—	—	—	—	—	CHPDAT<7:0>							0000	
3120	DCH1CON	31:16	—	—	—	—	—	—	—	—	—	—	—	—	—	—	—	0000
		15:0	CHBUSY	—	—	—	—	—	—	CHCHNS	CHEN	CHAED	CHCHN	CHAEN	—	CHEDET	CHPRI<1:0>	0000
3130	DCH1ECON	31:16	—	—	—	—	—	—	—	CHAIRQ<7:0>							00FF	
		15:0	CHSIRQ<7:0>							CFORCE	CABORT	PATEN	SIRQEN	AIRQEN	—	—	—	FF00
3140	DCH1INT	31:16	—	—	—	—	—	—	—	CHSDIE	CHSHIE	CHDDIE	CHDHIE	CHBCIE	CHCCIE	CHTAIE	CHERIE	0000
		15:0	—	—	—	—	—	—	—	CHSDIF	CHSHIF	CHDDIF	CHDHIF	CHBCIF	CHCCIF	CHTAIF	CHERIF	0000
3150	DCH1SSA	31:16	CHSSA<31:0>															0000
		15:0																0000
3160	DCH1DSA	31:16	CHDSA<31:0>															0000
		15:0																0000
3170	DCH1SSIZ	31:16	—	—	—	—	—	—	—	—	—	—	—	—	—	—	—	0000
		15:0	CHSSIZ<15:0>															0000

**Legend:** x = unknown value on Reset; — = unimplemented, read as '0'. Reset values are shown in hexadecimal.

**Note 1:** All registers in this table have corresponding CLR, SET and INV registers at their virtual addresses, plus offsets of 0x4, 0x8 and 0xC, respectively. See Section 12.1.1 "CLR, SET and INV Registers" for more information.

TABLE 4-19: DMA CHANNELS 0-7 REGISTER MAP<sup>(1)</sup> (CONTINUED)

Virtual Address (BF88_#)	Register Name	Bit Range	Bits															All Resets	
			31/15	30/14	29/13	28/12	27/11	26/10	25/9	24/8	23/7	22/6	21/5	20/4	19/3	18/2	17/1		16/0
3180	DCH1DSIZ	31:16	—	—	—	—	—	—	—	—	—	—	—	—	—	—	—	—	0000
		15:0	CHDSIZ<15:0>															0000	
3190	DCH1SPTR	31:16	—	—	—	—	—	—	—	—	—	—	—	—	—	—	—	—	0000
		15:0	CHSPTR<15:0>															0000	
31A0	DCH1DPTR	31:16	—	—	—	—	—	—	—	—	—	—	—	—	—	—	—	—	0000
		15:0	CHDPTR<15:0>															0000	
31B0	DCH1CSIZ	31:16	—	—	—	—	—	—	—	—	—	—	—	—	—	—	—	—	0000
		15:0	CHCSIZ<15:0>															0000	
31C0	DCH1CPTR	31:16	—	—	—	—	—	—	—	—	—	—	—	—	—	—	—	—	0000
		15:0	CHCPTR<15:0>															0000	
31D0	DCH1DAT	31:16	—	—	—	—	—	—	—	—	—	—	—	—	—	—	—	—	0000
		15:0	CHPDAT<7:0>															0000	
31E0	DCH2CON	31:16	—	—	—	—	—	—	—	—	—	—	—	—	—	—	—	—	0000
		15:0	CHBUSY	—	—	—	—	—	—	CHCHNS	CHEN	CHAED	CHCHN	CHAEN	—	CHEDET	CHPRI<1:0>	—	0000
31F0	DCH2ECON	31:16	—	—	—	—	—	—	—	—	—	—	—	—	—	—	—	—	00FF
		15:0	CHSIRQ<7:0>					CFORCE	CABORT	PATEN	SIRQEN	AIRQEN	—	—	—	—	—	—	FF00
3200	DCH2INT	31:16	—	—	—	—	—	—	—	—	—	—	—	—	—	—	—	—	0000
		15:0	—	—	—	—	—	—	—	—	CHSDIE	CHSHIE	CHDDIE	CHDHIE	CHBCIE	CHCCIE	CHTAIE	CHERIE	0000
3210	DCH2SSA	31:16	CHSSA<31:0>															0000	
		15:0																0000	
3220	DCH2DSA	31:16	CHDSA<31:0>															0000	
		15:0																0000	
3230	DCH2SSIZ	31:16	—	—	—	—	—	—	—	—	—	—	—	—	—	—	—	—	0000
		15:0	CHSSIZ<15:0>															0000	
3240	DCH2DSIZ	31:16	—	—	—	—	—	—	—	—	—	—	—	—	—	—	—	—	0000
		15:0	CHDSIZ<15:0>															0000	
3250	DCH2SPTR	31:16	—	—	—	—	—	—	—	—	—	—	—	—	—	—	—	—	0000
		15:0	CHSPTR<15:0>															0000	
3260	DCH2DPTR	31:16	—	—	—	—	—	—	—	—	—	—	—	—	—	—	—	—	0000
		15:0	CHDPTR<15:0>															0000	
3270	DCH2CSIZ	31:16	—	—	—	—	—	—	—	—	—	—	—	—	—	—	—	—	0000
		15:0	CHCSIZ<15:0>															0000	
3280	DCH2CPTR	31:16	—	—	—	—	—	—	—	—	—	—	—	—	—	—	—	—	0000
		15:0	CHCPTR<15:0>															0000	
3290	DCH2DAT	31:16	—	—	—	—	—	—	—	—	—	—	—	—	—	—	—	—	0000
		15:0	CHPDAT<7:0>															0000	

**Legend:** x = unknown value on Reset; — = unimplemented, read as '0'. Reset values are shown in hexadecimal.

**Note 1:** All registers in this table have corresponding CLR, SET and INV registers at their virtual addresses, plus offsets of 0x4, 0x8 and 0xC, respectively. See Section 12.1.1 "CLR, SET and INV Registers" for more information.

**TABLE 4-19: DMA CHANNELS 0-7 REGISTER MAP<sup>(1)</sup> (CONTINUED)**

Virtual Address (BF88_#)	Register Name	Bit Range	Bits														All Resets	
			31/15	30/14	29/13	28/12	27/11	26/10	25/9	24/8	23/7	22/6	21/5	20/4	19/3	18/2		17/1
32A0	DCH3CON	31:16	—	—	—	—	—	—	—	—	—	—	—	—	—	—	—	0000
		15:0	CHBUSY	—	—	—	—	—	—	CHCHNS	CHEN	CHAED	CHCHN	CHAEN	—	CHEDET	CHPRI<1:0>	0000
32B0	DCH3ECON	31:16	—	—	—	—	—	—	—	CHAIRQ<7:0>							00FF	
		15:0	CHSIRQ<7:0>						CFORCE	CABORT	PATEN	SIRQEN	AIRQEN	—	—	—	FF00	
32C0	DCH3INT	31:16	—	—	—	—	—	—	—	CHSDIE	CHSHIE	CHDDIE	CHDHIE	CHBCIE	CHCCIE	CHTAIE	CHERIE	0000
		15:0	—	—	—	—	—	—	—	CHSDIF	CHSHIF	CHDDIF	CHDHIF	CHBCIF	CHCCIF	CHTAIF	CHERIF	0000
32D0	DCH3SSA	31:16	CHSSA<31:0>														0000	
		15:0															0000	
32E0	DCH3DSA	31:16	CHDSA<31:0>														0000	
		15:0															0000	
32F0	DCH3SSIZ	31:16	—	—	—	—	—	—	—	—	—	—	—	—	—	—	—	0000
		15:0	CHSSIZ<15:0>														0000	
3300	DCH3DSIZ	31:16	—	—	—	—	—	—	—	—	—	—	—	—	—	—	—	0000
		15:0	CHDSIZ<15:0>														0000	
3310	DCH3SPTR	31:16	—	—	—	—	—	—	—	—	—	—	—	—	—	—	—	0000
		15:0	CHSPTR<15:0>														0000	
3320	DCH3DPTR	31:16	—	—	—	—	—	—	—	—	—	—	—	—	—	—	—	0000
		15:0	CHDPTR<15:0>														0000	
3330	DCH3CSIZ	31:16	—	—	—	—	—	—	—	—	—	—	—	—	—	—	—	0000
		15:0	CHCSIZ<15:0>														0000	
3340	DCH3CPTR	31:16	—	—	—	—	—	—	—	—	—	—	—	—	—	—	—	0000
		15:0	CHCPTR<15:0>														0000	
3350	DCH3DAT	31:16	—	—	—	—	—	—	—	—	—	—	—	—	—	—	—	0000
		15:0	CHPDAT<7:0>														0000	
3360	DCH4CON	31:16	—	—	—	—	—	—	—	—	—	—	—	—	—	—	—	0000
		15:0	CHBUSY	—	—	—	—	—	—	CHCHNS	CHEN	CHAED	CHCHN	CHAEN	—	CHEDET	CHPRI<1:0>	0000
3370	DCH4ECON	31:16	—	—	—	—	—	—	—	CHAIRQ<7:0>							00FF	
		15:0	CHSIRQ<7:0>						CFORCE	CABORT	PATEN	SIRQEN	AIRQEN	—	—	—	FF00	
3380	DCH4INT	31:16	—	—	—	—	—	—	—	CHSDIE	CHSHIE	CHDDIE	CHDHIE	CHBCIE	CHCCIE	CHTAIE	CHERIE	0000
		15:0	—	—	—	—	—	—	—	CHSDIF	CHSHIF	CHDDIF	CHDHIF	CHBCIF	CHCCIF	CHTAIF	CHERIF	0000
3390	DCH4SSA	31:16	CHSSA<31:0>														0000	
		15:0															0000	
33A0	DCH4DSA	31:16	CHDSA<31:0>														0000	
		15:0															0000	
33B0	DCH4SSIZ	31:16	—	—	—	—	—	—	—	—	—	—	—	—	—	—	—	0000
		15:0	CHSSIZ15:0>														0000	

**Legend:** x = unknown value on Reset; — = unimplemented, read as '0'. Reset values are shown in hexadecimal.

**Note 1:** All registers in this table have corresponding CLR, SET and INV registers at their virtual addresses, plus offsets of 0x4, 0x8 and 0xC, respectively. See Section 12.1.1 "CLR, SET and INV Registers" for more information.

TABLE 4-19: DMA CHANNELS 0-7 REGISTER MAP<sup>(1)</sup> (CONTINUED)

Virtual Address (BF88_#)	Register Name	Bit Range	Bits															All Resets	
			31/15	30/14	29/13	28/12	27/11	26/10	25/9	24/8	23/7	22/6	21/5	20/4	19/3	18/2	17/1		16/0
33C0	DCH4DSIZ	31:16	—	—	—	—	—	—	—	—	—	—	—	—	—	—	—	—	0000
		15:0	CHDSIZ<15:0>															0000	
33D0	DCH4SPTR	31:16	—	—	—	—	—	—	—	—	—	—	—	—	—	—	—	—	0000
		15:0	CHSPTR<15:0>															0000	
33E0	DCH4DPTR	31:16	—	—	—	—	—	—	—	—	—	—	—	—	—	—	—	—	0000
		15:0	CHDPTR<15:0>															0000	
33F0	DCH4CSIZ	31:16	—	—	—	—	—	—	—	—	—	—	—	—	—	—	—	—	0000
		15:0	CHCSIZ<15:0>															0000	
3400	DCH4CPTR	31:16	—	—	—	—	—	—	—	—	—	—	—	—	—	—	—	—	0000
		15:0	CHCPTR<15:0>															0000	
3410	DCH4DAT	31:16	—	—	—	—	—	—	—	—	—	—	—	—	—	—	—	—	0000
		15:0	CHPDAT<7:0>															0000	
3420	DCH5CON	31:16	—	—	—	—	—	—	—	—	—	—	—	—	—	—	—	—	0000
		15:0	CHBUSY	—	—	—	—	—	—	CHCHNS	CHEN	CHAED	CHCHN	CHAEN	—	CHEDET	CHPRI<1:0>	—	0000
3430	DCH5ECON	31:16	—	—	—	—	—	—	—	—	—	—	—	—	—	—	—	—	00FF
		15:0	CHSIRQ<7:0>															FF00	
3440	DCH5INT	31:16	—	—	—	—	—	—	—	—	—	—	—	—	—	—	—	—	0000
		15:0	—	—	—	—	—	—	—	—	CHSDIE	CHSHIE	CHDDIE	CHDHIE	CHBCIE	CHCCIE	CHTAIE	CHERIE	0000
3450	DCH5SSA	31:16	CHSSA<31:0>															0000	
		15:0	CHSSA<31:0>															0000	
3460	DCH5DSA	31:16	CHDSA<31:0>															0000	
		15:0	CHDSA<31:0>															0000	
3470	DCH5SSIZ	31:16	—	—	—	—	—	—	—	—	—	—	—	—	—	—	—	—	0000
		15:0	CHSSIZ<15:0>															0000	
3480	DCH5DSIZ	31:16	—	—	—	—	—	—	—	—	—	—	—	—	—	—	—	—	0000
		15:0	CHDSIZ<15:0>															0000	
3490	DCH5SPTR	31:16	—	—	—	—	—	—	—	—	—	—	—	—	—	—	—	—	0000
		15:0	CHSPTR<15:0>															0000	
34A0	DCH5DPTR	31:16	—	—	—	—	—	—	—	—	—	—	—	—	—	—	—	—	0000
		15:0	CHDPTR<15:0>															0000	
34B0	DCH5CSIZ	31:16	—	—	—	—	—	—	—	—	—	—	—	—	—	—	—	—	0000
		15:0	CHCSIZ<15:0>															0000	
34C0	DCH5CPTR	31:16	—	—	—	—	—	—	—	—	—	—	—	—	—	—	—	—	0000
		15:0	CHCPTR<15:0>															0000	
34D0	DCH5DAT	31:16	—	—	—	—	—	—	—	—	—	—	—	—	—	—	—	—	0000
		15:0	CHPDAT<7:0>															0000	

**Legend:** x = unknown value on Reset; — = unimplemented, read as '0'. Reset values are shown in hexadecimal.

**Note 1:** All registers in this table have corresponding CLR, SET and INV registers at their virtual addresses, plus offsets of 0x4, 0x8 and 0xC, respectively. See Section 12.1.1 "CLR, SET and INV Registers" for more information.



**TABLE 4-19: DMA CHANNELS 0-7 REGISTER MAP<sup>(1)</sup> (CONTINUED)**

Virtual Address (BF88_#)	Register Name	Bit Range	Bits														All Resets	
			31/15	30/14	29/13	28/12	27/11	26/10	25/9	24/8	23/7	22/6	21/5	20/4	19/3	18/2		17/1
34E0	DCH6CON	31:16	—	—	—	—	—	—	—	—	—	—	—	—	—	—	—	0000
		15:0	CHBUSY	—	—	—	—	—	—	CHCHNS	CHEN	CHAED	CHCHN	CHAEN	—	CHEDET	CHPRI<1:0>	0000
34F0	DCH6ECON	31:16	—	—	—	—	—	—	—	CHAIRQ<7:0>							00FF	
		15:0	CHSIRQ<7:0>						CFORCE	CABORT	PATEN	SIRQEN	AIRQEN	—	—	—	FF00	
3500	DCH6INT	31:16	—	—	—	—	—	—	—	CHSDIE	CHSHIE	CHDDIE	CHDHIE	CHBCIE	CHCCIE	CHTAIE	CHERIE	0000
		15:0	—	—	—	—	—	—	—	CHSDIF	CHSHIF	CHDDIF	CHDHIF	CHBCIF	CHCCIF	CHTAIF	CHERIF	0000
3510	DCH6SSA	31:16	CHSSA<31:0>														0000	
		15:0															0000	
3520	DCH6DSA	31:16	CHDSA<31:0>														0000	
		15:0															0000	
3530	DCH6SSIZ	31:16	—	—	—	—	—	—	—	—	—	—	—	—	—	—	—	0000
		15:0	CHSSIZ<15:0>														0000	
3540	DCH6DSIZ	31:16	—	—	—	—	—	—	—	—	—	—	—	—	—	—	—	0000
		15:0	CHDSIZ<15:0>														0000	
3550	DCH6SPTR	31:16	—	—	—	—	—	—	—	—	—	—	—	—	—	—	—	0000
		15:0	CHSPTR<15:0>														0000	
3560	DCH6DPTR	31:16	—	—	—	—	—	—	—	—	—	—	—	—	—	—	—	0000
		15:0	CHDPTR<15:0>														0000	
3570	DCH6CSIZ	31:16	—	—	—	—	—	—	—	—	—	—	—	—	—	—	—	0000
		15:0	CHCSIZ<15:0>														0000	
3580	DCH6CPTR	31:16	—	—	—	—	—	—	—	—	—	—	—	—	—	—	—	0000
		15:0	CHCPTR<15:0>														0000	
3590	DCH6DAT	31:16	—	—	—	—	—	—	—	—	—	—	—	—	—	—	—	0000
		15:0	CHPDAT<7:0>														0000	
35A0	DCH7CON	31:16	—	—	—	—	—	—	—	—	—	—	—	—	—	—	—	0000
		15:0	CHBUSY	—	—	—	—	—	—	CHCHNS	CHEN	CHAED	CHCHN	CHAEN	—	CHEDET	CHPRI<1:0>	0000
35B0	DCH7ECON	31:16	—	—	—	—	—	—	—	CHAIRQ<7:0>							00FF	
		15:0	CHSIRQ<7:0>						CFORCE	CABORT	PATEN	SIRQEN	AIRQEN	—	—	—	FF00	
35C0	DCH7INT	31:16	—	—	—	—	—	—	—	CHSDIE	CHSHIE	CHDDIE	CHDHIE	CHBCIE	CHCCIE	CHTAIE	CHERIE	0000
		15:0	—	—	—	—	—	—	—	CHSDIF	CHSHIF	CHDDIF	CHDHIF	CHBCIF	CHCCIF	CHTAIF	CHERIF	0000
35D0	DCH7SSA	31:16	CHSSA<31:0>														0000	
		15:0															0000	
35E0	DCH7DSA	31:16	CHDSA<31:0>														0000	
		15:0															0000	
35F0	DCH7SSIZ	31:16	—	—	—	—	—	—	—	—	—	—	—	—	—	—	—	0000
		15:0	CHSSIZ<15:0>														0000	

**Legend:** × = unknown value on Reset; — = unimplemented, read as '0'. Reset values are shown in hexadecimal.

**Note 1:** All registers in this table have corresponding CLR, SET and INV registers at their virtual addresses, plus offsets of 0x4, 0x8 and 0xC, respectively. See Section 12.1.1 "CLR, SET and INV Registers" for more information.

**TABLE 4-19: DMA CHANNELS 0-7 REGISTER MAP<sup>(1)</sup> (CONTINUED)**

Virtual Address (BF88_#)	Register Name	Bit Range	Bits														All Resets		
			31/15	30/14	29/13	28/12	27/11	26/10	25/9	24/8	23/7	22/6	21/5	20/4	19/3	18/2		17/1	16/0
3600	DCH7DSIZ	31:16	—	—	—	—	—	—	—	—	—	—	—	—	—	—	—	—	0000
		15:0	CHDSIZ<15:0>														0000		
3610	DCH7SPTR	31:16	—	—	—	—	—	—	—	—	—	—	—	—	—	—	—	—	0000
		15:0	CHSPTR<15:0>														0000		
3620	DCH7DPTR	31:16	—	—	—	—	—	—	—	—	—	—	—	—	—	—	—	—	0000
		15:0	CHDPTR<15:0>														0000		
3630	DCH7CSIZ	31:16	—	—	—	—	—	—	—	—	—	—	—	—	—	—	—	—	0000
		15:0	CHCSIZ<15:0>														0000		
3640	DCH7CPTR	31:16	—	—	—	—	—	—	—	—	—	—	—	—	—	—	—	—	0000
		15:0	CHCPTR<15:0>														0000		
3650	DCH7DAT	31:16	—	—	—	—	—	—	—	—	—	—	—	—	—	—	—	—	0000
		15:0	CHPDAT<7:0>														0000		

**Legend:** x = unknown value on Reset; — = unimplemented, read as '0'. Reset values are shown in hexadecimal.

**Note 1:** All registers in this table have corresponding CLR, SET and INV registers at their virtual addresses, plus offsets of 0x4, 0x8 and 0xC, respectively. See Section 12.1.1 “CLR, SET and INV Registers” for more information.

**TABLE 4-20: COMPARATOR REGISTER MAP<sup>(1)</sup>**

Virtual Address (BF80_#)	Register Name	Bit Range	Bits															All Resets
			31/15	30/14	29/13	28/12	27/11	26/10	25/9	24/8	23/7	22/6	21/5	20/4	19/3	18/2	17/1	
A000	CM1CON	31:16	—	—	—	—	—	—	—	—	—	—	—	—	—	—	—	0000
		15:0	ON	COE	CPOL	—	—	—	—	COUT	EVPOL<1:0>	—	—	CREF	—	—	—	CCH<1:0>
A010	CM2CON	31:16	—	—	—	—	—	—	—	—	—	—	—	—	—	—	—	0000
		15:0	ON	COE	CPOL	—	—	—	—	COUT	EVPOL<1:0>	—	—	CREF	—	—	—	CCH<1:0>
A060	CMSTAT	31:16	—	—	—	—	—	—	—	—	—	—	—	—	—	—	—	0000
		15:0	—	FRZ	SIDL	—	—	—	—	—	—	—	—	—	—	—	—	C2OUT C1OUT

**Legend:** x = unknown value on Reset; — = unimplemented, read as '0'. Reset values are shown in hexadecimal.

**Note 1:** All registers in this table have corresponding CLR, SET and INV registers at their virtual addresses, plus offsets of 0x4, 0x8 and 0xC, respectively. See Section 12.1.1 “CLR, SET and INV Registers” for more information.

**TABLE 4-21: COMPARATOR VOLTAGE REFERENCE REGISTER MAP<sup>(1)</sup>**

Virtual Address (BF80_#)	Register Name	Bit Range	Bits															All Resets
			31/15	30/14	29/13	28/12	27/11	26/10	25/9	24/8	23/7	22/6	21/5	20/4	19/3	18/2	17/1	
9800	CVRCON	31:16	—	—	—	—	—	—	—	—	—	—	—	—	—	—	—	0000
		15:0	ON	—	—	—	—	—	VREFSEL <sup>(3)</sup>	BGSEL<1:0> <sup>(3)</sup>	—	CVROE	CVRR	CVRSS	—	—	—	CVR<3:0> <sup>(2)</sup>

**Legend:** x = unknown value on Reset; — = unimplemented, read as '0'. Reset values are shown in hexadecimal.

**Note 1:** All registers in this table have corresponding CLR, SET and INV registers at their virtual addresses, plus offsets of 0x4, 0x8 and 0xC, respectively. See Section 12.1.1 “CLR, SET and INV Registers” for more information.

**2:** On devices with less than 256K of memory, these bits do not exist and are treated as reserved.

**3:** These bits are not available on PIC32MX575/675/695/775 devices.

TABLE 4-22: FLASH CONTROLLER REGISTER MAP

Virtual Address (BF80_#)	Register Name	Bit Range	Bits															All Resets	
			31/15	30/14	29/13	28/12	27/11	26/10	25/9	24/8	23/7	22/6	21/5	20/4	19/3	18/2	17/1		16/0
F400	NVMCON <sup>(1)</sup>	31:16	—	—	—	—	—	—	—	—	—	—	—	—	—	—	—	—	0000
		15:0	WR	WREN	WRERR	LVDERR	LVDSTAT	—	—	—	—	—	—	—	—	NVMOP<3:0>			0000
F410	NVMKEY	31:16	NVMKEY<31:0>															0000	
		15:0																0000	
F420	NVMADDR <sup>(1)</sup>	31:16	NVMADDR<31:0>															0000	
		15:0																0000	
F430	NVMDATA	31:16	NVMDATA<31:0>															0000	
		15:0																0000	
F440	NVMSRC ADDR	31:16	NVMSRCADDR<31:0>															0000	
		15:0																0000	

**Legend:** x = unknown value on Reset; — = unimplemented, read as '0'. Reset values are shown in hexadecimal.

**Note 1:** This register has corresponding CLR, SET and INV registers at their virtual addresses, plus offsets of 0x4, 0x8 and 0xC, respectively. See Section 12.1.1 “CLR, SET and INV Registers” for more information.

TABLE 4-23: SYSTEM CONTROL REGISTER MAP<sup>(1,2)</sup>

Virtual Address (BF80_#)	Register Name	Bit Range	Bits															All Resets <sup>(2)</sup>	
			31/15	30/14	29/13	28/12	27/11	26/10	25/9	24/8	23/7	22/6	21/5	20/4	19/3	18/2	17/1		16/0
F000	OSCCON	31:16	—	—	PLLODIV<2:0>			FRCDIV<2:0>			—	SOSCRDY	—	PBDIV<1:0>		PLLMULT<2:0>			0000
		15:0	—	COSCC<2:0>			—	NOSC<2:0>			CLKLOCK	ULOCK	SLOCK	SLPEN	CF	UFRCCN	SOSCEN	OSWEN	0000
F010	OSCTUN	31:16	—	—	—	—	—	—	—	—	—	—	—	—	—	—	—	0000	
		15:0	—	—	—	—	—	—	—	—	—	TUN<5:0>					—	—	0000
0000	WDTCON	31:16	—	—	—	—	—	—	—	—	—	—	—	—	—	—	—	0000	
		15:0	ON	—	—	—	—	—	—	—	SWDTPS<4:0>					—	WDTCLR	0000	
F600	RCON	31:16	—	—	—	—	—	—	—	—	—	—	—	—	—	—	—	0000	
		15:0	—	—	—	—	—	—	CMR	VREGS	EXTR	SWR	—	WDTO	SLEEP	IDLE	BOR	POR	0000
F610	RSWRST	31:16	—	—	—	—	—	—	—	—	—	—	—	—	—	—	—	0000	
		15:0	—	—	—	—	—	—	—	—	—	—	—	—	—	—	—	SWRST	0000
F230	SYSKEY	31:16	SYSKEY<31:0>															0000	
		15:0																0000	

**Legend:** x = unknown value on Reset; — = unimplemented, read as '0'. Reset values are shown in hexadecimal.

**Note 1:** All registers in this table have corresponding CLR, SET and INV registers at their virtual addresses, plus offsets of 0x4, 0x8 and 0xC, respectively. See Section 12.1.1 “CLR, SET and INV Registers” for more information.

**2:** Reset values are dependent on the DEVCFGx Configuration bits and the type of Reset.

**TABLE 4-24: PORTA REGISTER MAP FOR PIC32MX575F256L, PIC32MX575F512L, PIC32MX675F256L, PIC32MX675F512L, PIC32MX695F512L, PIC32MX775F256L, PIC32MX775F512L AND PIC32MX795F512L DEVICES<sup>(1)</sup>**

Virtual Address (BF88_#)	Register Name	Bit Range	Bits																All Resets
			31/15	30/14	29/13	28/12	27/11	26/10	25/9	24/8	23/7	22/6	21/5	20/4	19/3	18/2	17/1	16/0	
6000	TRISA	31:16	—	—	—	—	—	—	—	—	—	—	—	—	—	—	—	—	0000
		15:0	TRISA15	TRISA14	—	—	—	TRISA10	TRISA9	—	TRISA7	TRISA6	TRISA5	TRISA4	TRISA3	TRISA2	TRISA1	TRISA0	C6FF
6010	PORTA	31:16	—	—	—	—	—	—	—	—	—	—	—	—	—	—	—	—	0000
		15:0	RA15	RA14	—	—	—	RA10	RA9	—	RA7	RA6	RA5	RA4	RA3	RA2	RA1	RA0	xxxx
6020	LATA	31:16	—	—	—	—	—	—	—	—	—	—	—	—	—	—	—	—	0000
		15:0	LATA15	LATA14	—	—	—	LATA10	LATA9	—	LATA7	LATA6	LATA5	LATA4	LATA3	LATA2	LATA1	LATA0	xxxx
6030	ODCA	31:16	—	—	—	—	—	—	—	—	—	—	—	—	—	—	—	—	0000
		15:0	ODCA15	ODCA14	—	—	—	ODCA10	ODCA9	—	ODCA7	ODCA6	ODCA5	ODCA4	ODCA3	ODCA2	ODCA1	ODCA0	0000

**Legend:** x = unknown value on Reset; — = unimplemented, read as '0'. Reset values are shown in hexadecimal.

**Note 1:** All registers in this table have corresponding CLR, SET and INV registers at their virtual addresses, plus offsets of 0x4, 0x8 and 0xC, respectively. See Section 12.1.1 “CLR, SET and INV Registers” for more information.

**TABLE 4-25: PORTB REGISTER MAP<sup>(1)</sup>**

Virtual Address (BF88_#)	Register Name	Bit Range	Bits																All Resets
			31/15	30/14	29/13	28/12	27/11	26/10	25/9	24/8	23/7	22/6	21/5	20/4	19/3	18/2	17/1	16/0	
6040	TRISB	31:16	—	—	—	—	—	—	—	—	—	—	—	—	—	—	—	—	0000
		15:0	TRISB15	TRISB14	TRISB13	TRISB12	TRISB11	TRISB10	TRISB9	TRISB8	TRISB7	TRISB6	TRISB5	TRISB4	TRISB3	TRISB2	TRISB1	TRISB0	FFFF
6050	PORTB	31:16	—	—	—	—	—	—	—	—	—	—	—	—	—	—	—	—	0000
		15:0	RB15	RB14	RB13	RB12	RB11	RB10	RB9	RB8	RB7	RB6	RB5	RB4	RB3	RB2	RB1	RB0	xxxx
6060	LATB	31:16	—	—	—	—	—	—	—	—	—	—	—	—	—	—	—	—	0000
		15:0	LATB15	LATB14	LATB13	LATB12	LATB11	LATB10	LATB9	LATB8	LATB7	LATB6	LATB5	LATB4	LATB3	LATB2	LATB1	LATB0	xxxx
6070	ODCB	31:16	—	—	—	—	—	—	—	—	—	—	—	—	—	—	—	—	0000
		15:0	ODCB15	ODCB14	ODCB13	ODCB12	ODCB11	ODCB10	ODCB9	ODCB8	ODCB7	ODCB6	ODCB5	ODCB4	ODCB3	ODCB2	ODCB1	ODCB0	0000

**Legend:** x = unknown value on Reset; — = unimplemented, read as '0'. Reset values are shown in hexadecimal.

**Note 1:** All registers in this table have corresponding CLR, SET and INV registers at their virtual addresses, plus offsets of 0x4, 0x8 and 0xC, respectively. See Section 12.1.1 “CLR, SET and INV Registers” for more information.

**TABLE 4-26: PORTC REGISTER MAP FOR PIC32MX575F256H, PIC32MX575F512H, PIC32MX675F256H, PIC32MX675F512H, PIC32MX695F512H, PIC32MX775F256H, PIC32MX775F512H AND PIC32MX795F512H DEVICES<sup>(1)</sup>**

Virtual Address (BF88_#)	Register Name	Bit Range	Bits															All Resets	
			31/15	30/14	29/13	28/12	27/11	26/10	25/9	24/8	23/7	22/6	21/5	20/4	19/3	18/2	17/1		16/0
6080	TRISC	31:16	—	—	—	—	—	—	—	—	—	—	—	—	—	—	—	—	0000
		15:0	TRISC15	TRISC14	TRISC13	TRISC12	—	—	—	—	—	—	—	—	—	—	—	—	F000
6090	PORTC	31:16	—	—	—	—	—	—	—	—	—	—	—	—	—	—	—	—	0000
		15:0	RC15	RC14	RC13	RC12	—	—	—	—	—	—	—	—	—	—	—	—	xxxx
60A0	LATC	31:16	—	—	—	—	—	—	—	—	—	—	—	—	—	—	—	—	0000
		15:0	LATC15	LATC14	LATC13	LATC12	—	—	—	—	—	—	—	—	—	—	—	—	xxxx
60B0	ODCC	31:16	—	—	—	—	—	—	—	—	—	—	—	—	—	—	—	—	0000
		15:0	ODCC15	ODCC14	ODCC13	ODCC12	—	—	—	—	—	—	—	—	—	—	—	—	0000

**Legend:** x = unknown value on Reset; — = unimplemented, read as '0'. Reset values are shown in hexadecimal.

**Note 1:** All registers in this table have corresponding CLR, SET and INV registers at their virtual addresses, plus offsets of 0x4, 0x8 and 0xC, respectively. See Section 12.1.1 “CLR, SET and INV Registers” for more information.

**TABLE 4-27: PORTC REGISTER MAP FOR PIC32MX575F256L, PIC32MX575F512L, PIC32MX675F256L, PIC32MX675F512L, PIC32MX695F512L, PIC32MX775F256L, PIC32MX775F512L AND PIC32MX795F512L DEVICES<sup>(1)</sup>**

Virtual Address (BF88_#)	Register Name	Bit Range	Bits															All Resets	
			31/15	30/14	29/13	28/12	27/11	26/10	25/9	24/8	23/7	22/6	21/5	20/4	19/3	18/2	17/1		16/0
6080	TRISC	31:16	—	—	—	—	—	—	—	—	—	—	—	—	—	—	—	—	0000
		15:0	TRISC15	TRISC14	TRISC13	TRISC12	—	—	—	—	—	—	—	TRISC4	TRISC3	TRISC2	TRISC1	—	F00F
6090	PORTC	31:16	—	—	—	—	—	—	—	—	—	—	—	—	—	—	—	—	0000
		15:0	RC15	RC14	RC13	RC12	—	—	—	—	—	—	—	RC4	RC3	RC2	RC1	—	xxxx
60A0	LATC	31:16	—	—	—	—	—	—	—	—	—	—	—	—	—	—	—	—	0000
		15:0	LATC15	LATC14	LATC13	LATC12	—	—	—	—	—	—	—	LATC4	LATC3	LATC2	LATC1	—	xxxx
60B0	ODCC	31:16	—	—	—	—	—	—	—	—	—	—	—	—	—	—	—	—	0000
		15:0	ODCC15	ODCC14	ODCC13	ODCC12	—	—	—	—	—	—	—	ODCC4	ODCC3	ODCC2	ODCC1	—	0000

**Legend:** x = unknown value on Reset; — = unimplemented, read as '0'. Reset values are shown in hexadecimal.

**Note 1:** All registers in this table have corresponding CLR, SET and INV registers at their virtual addresses, plus offsets of 0x4, 0x8 and 0xC, respectively. See Section 12.1.1 “CLR, SET and INV Registers” for more information.

**TABLE 4-28: PORTD REGISTER MAP FOR PIC32MX575F256H, PIC32MX575F512H, PIC32MX675F256H, PIC32MX675F512H, PIC32MX695F512H, PIC32MX775F256H, PIC32MX775F512H AND PIC32MX795F512H DEVICES<sup>(1)</sup>**

Virtual Address (BF88_#)	Register Name	Bit Range	Bits																All Resets	
			31/15	30/14	29/13	28/12	27/11	26/10	25/9	24/8	23/7	22/6	21/5	20/4	19/3	18/2	17/1	16/0		
60C0	TRISD	31:16	—	—	—	—	—	—	—	—	—	—	—	—	—	—	—	—	—	0000
		15:0	—	—	—	—	—	TRISD11	TRISD10	TRISD9	TRISD8	TRISD7	TRISD6	TRISD5	TRISD4	TRISD3	TRISD2	TRISD1	TRISD0	0FFF
60D0	PORTD	31:16	—	—	—	—	—	—	—	—	—	—	—	—	—	—	—	—	—	0000
		15:0	—	—	—	—	—	RD11	RD10	RD9	RD8	RD7	RD6	RD5	RD4	RD3	RD2	RD1	RD0	xxxx
60E0	LATD	31:16	—	—	—	—	—	—	—	—	—	—	—	—	—	—	—	—	—	0000
		15:0	—	—	—	—	—	LATD11	LATD10	LATD9	LATD8	LATD7	LATD6	LATD5	LATD4	LATD3	LATD2	LATD1	LATD0	xxxx
60F0	ODCD	31:16	—	—	—	—	—	—	—	—	—	—	—	—	—	—	—	—	—	0000
		15:0	—	—	—	—	—	ODCD11	ODCD10	ODCD9	ODCD8	ODCD7	ODCD6	ODCD5	ODCD4	ODCD3	ODCD2	ODCD1	ODCD0	0000

**Legend:** x = unknown value on Reset; — = unimplemented, read as '0'. Reset values are shown in hexadecimal.

**Note 1:** All registers in this table have corresponding CLR, SET and INV registers at their virtual addresses, plus offsets of 0x4, 0x8 and 0xC, respectively. See Section 12.1.1 “CLR, SET and INV Registers” for more information.

**TABLE 4-29: PORTD REGISTER MAP FOR PIC32MX575F256L, PIC32MX575F512L, PIC32MX675F256L, PIC32MX675F512L, PIC32MX695F512L, PIC32MX775F256L, PIC32MX775F512L AND PIC32MX795F512L DEVICES<sup>(1)</sup>**

Virtual Address (BF88_#)	Register Name	Bit Range	Bits																All Resets	
			31/15	30/14	29/13	28/12	27/11	26/10	25/9	24/8	23/7	22/6	21/5	20/4	19/3	18/2	17/1	16/0		
60C0	TRISD	31:16	—	—	—	—	—	—	—	—	—	—	—	—	—	—	—	—	—	0000
		15:0	TRISD15	TRISD14	TRISD13	TRISD12	TRISD11	TRISD10	TRISD9	TRISD8	TRISD7	TRISD6	TRISD5	TRISD4	TRISD3	TRISD2	TRISD1	TRISD0	FFFF	
60D0	PORTD	31:16	—	—	—	—	—	—	—	—	—	—	—	—	—	—	—	—	—	0000
		15:0	RD15	RD14	RD13	RD12	RD11	RD10	RD9	RD8	RD7	RD6	RD5	RD4	RD3	RD2	RD1	RD0	xxxx	
60E0	LATD	31:16	—	—	—	—	—	—	—	—	—	—	—	—	—	—	—	—	—	0000
		15:0	LAT15	LAT14	LAT13	LAT12	LATD11	LATD10	LATD9	LATD8	LATD7	LATD6	LATD5	LATD4	LATD3	LATD2	LATD1	LATD0	xxxx	
60F0	ODCD	31:16	—	—	—	—	—	—	—	—	—	—	—	—	—	—	—	—	—	0000
		15:0	ODCD15	ODCD14	ODCD13	ODCD12	ODCD11	ODCD10	ODCD9	ODCD8	ODCD7	ODCD6	ODCD5	ODCD4	ODCD3	ODCD2	ODCD1	ODCD0	0000	

**Legend:** x = unknown value on Reset; — = unimplemented, read as '0'. Reset values are shown in hexadecimal.

**Note 1:** All registers in this table have corresponding CLR, SET and INV registers at their virtual addresses, plus offsets of 0x4, 0x8 and 0xC, respectively. See Section 12.1.1 “CLR, SET and INV Registers” for more information.

**TABLE 4-30: PORTE REGISTER MAP FOR PIC32MX575F256H, PIC32MX575F512H, PIC32MX675F256H, PIC32MX675F512H, PIC32MX695F512H, PIC32MX775F256H, PIC32MX775F512H AND PIC32MX795F512H DEVICES<sup>(1)</sup>**

Virtual Address (BF88_#)	Register Name	Bit Range	Bits																All Resets
			31/15	30/14	29/13	28/12	27/11	26/10	25/9	24/8	23/7	22/6	21/5	20/4	19/3	18/2	17/1	16/0	
6100	TRISE	31:16	—	—	—	—	—	—	—	—	—	—	—	—	—	—	—	—	0000
		15:0	—	—	—	—	—	—	—	—	TRISE7	TRISE6	TRISE5	TRISE4	TRISE3	TRISE2	TRISE1	TRISE0	00FF
6110	PORTE	31:16	—	—	—	—	—	—	—	—	—	—	—	—	—	—	—	0000	
		15:0	—	—	—	—	—	—	—	—	RE7	RE6	RE5	RE4	RE3	RE2	RE1	RE0	xxxx
6120	LATE	31:16	—	—	—	—	—	—	—	—	—	—	—	—	—	—	—	0000	
		15:0	—	—	—	—	—	—	—	—	LATE7	LATE6	LATE5	LATE4	LATE3	LATE2	LATE1	LATE0	xxxx
6130	ODCE	31:16	—	—	—	—	—	—	—	—	—	—	—	—	—	—	—	0000	
		15:0	—	—	—	—	—	—	—	—	ODCE7	ODCE6	ODCE5	ODCE4	ODCE3	ODCE2	ODCE1	ODCE0	0000

**Legend:** x = unknown value on Reset; — = unimplemented, read as '0'. Reset values are shown in hexadecimal.

**Note 1:** All registers in this table have corresponding CLR, SET and INV registers at their virtual addresses, plus offsets of 0x4, 0x8 and 0xC, respectively. See Section 12.1.1 “CLR, SET and INV Registers” for more information.

**TABLE 4-31: PORTE REGISTER MAP FOR PIC32MX575F256L, PIC32MX575F512L, PIC32MX675F256L, PIC32MX675F512L, PIC32MX695F512L, PIC32MX775F256L, PIC32MX775F512L AND PIC32MX795F512L DEVICES<sup>(1)</sup>**

Virtual Address (BF88_#)	Register Name	Bit Range	Bits																All Resets
			31/15	30/14	29/13	28/12	27/11	26/10	25/9	24/8	23/7	22/6	21/5	20/4	19/3	18/2	17/1	16/0	
6100	TRISE	31:16	—	—	—	—	—	—	—	—	—	—	—	—	—	—	—	0000	
		15:0	—	—	—	—	—	—	—	TRISE9	TRISE8	TRISE7	TRISE6	TRISE5	TRISE4	TRISE3	TRISE2	TRISE1	TRISE0
6110	PORTE	31:16	—	—	—	—	—	—	—	—	—	—	—	—	—	—	—	0000	
		15:0	—	—	—	—	—	—	—	RE9	RE8	RE7	RE6	RE5	RE4	RE3	RE2	RE1	RE0
6120	LATE	31:16	—	—	—	—	—	—	—	—	—	—	—	—	—	—	—	0000	
		15:0	—	—	—	—	—	—	—	LATE9	LATE8	LATE7	LATE6	LATE5	LATE4	LATE3	LATE2	LATE1	LATE0
6130	ODCE	31:16	—	—	—	—	—	—	—	—	—	—	—	—	—	—	—	0000	
		15:0	—	—	—	—	—	—	—	—	ODCE9	ODCE8	ODCE7	ODCE6	ODCE5	ODCE4	ODCE3	ODCE2	ODCE1

**Legend:** x = unknown value on Reset; — = unimplemented, read as '0'. Reset values are shown in hexadecimal.

**Note 1:** All registers in this table have corresponding CLR, SET and INV registers at their virtual addresses, plus offsets of 0x4, 0x8 and 0xC, respectively. See Section 12.1.1 “CLR, SET and INV Registers” for more information.



**TABLE 4-32: PORTF REGISTER MAP FOR PIC32MX575F256H, PIC32MX575F512H, PIC32MX675F256H, PIC32MX675F512H, PIC32MX695F512H, PIC32MX775F256H, PIC32MX775F512H AND PIC32MX795F512H DEVICES<sup>(1)</sup>**

Virtual Address (BF88_#)	Register Name	Bit Range	Bits															All Resets	
			31/15	30/14	29/13	28/12	27/11	26/10	25/9	24/8	23/7	22/6	21/5	20/4	19/3	18/2	17/1		16/0
6140	TRISF	31:16	—	—	—	—	—	—	—	—	—	—	—	—	—	—	—	—	0000
		15:0	—	—	—	—	—	—	—	—	—	—	TRISF5	TRISF4	TRISF3	—	TRISF1	TRISF0	003B
6150	PORTF	31:16	—	—	—	—	—	—	—	—	—	—	—	—	—	—	—	—	0000
		15:0	—	—	—	—	—	—	—	—	—	—	RF5	RF4	RF3	—	RF1	RF0	xxxx
6160	LATF	31:16	—	—	—	—	—	—	—	—	—	—	—	—	—	—	—	—	0000
		15:0	—	—	—	—	—	—	—	—	—	—	LATF5	LATF4	LATF3	—	LATF1	LATF0	xxxx
6170	ODCF	31:16	—	—	—	—	—	—	—	—	—	—	—	—	—	—	—	—	0000
		15:0	—	—	—	—	—	—	—	—	—	—	ODCF5	ODCF4	ODCF3	—	ODCF1	ODCF0	0000

**Legend:** x = unknown value on Reset; — = unimplemented, read as '0'. Reset values are shown in hexadecimal.

**Note 1:** All registers in this table have corresponding CLR, SET and INV registers at their virtual addresses, plus offsets of 0x4, 0x8 and 0xC, respectively. See Section 12.1.1 “CLR, SET and INV Registers” for more information.

**TABLE 4-33: PORTF REGISTER MAP FOR PIC32MX575F256L, PIC32MX575F512L, PIC32MX675F256L, PIC32MX675F512L, PIC32MX695F512L, PIC32MX775F256L, PIC32MX775F512L AND PIC32MX795F512L DEVICES<sup>(1)</sup>**

Virtual Address (BF88_#)	Register Name	Bit Range	Bits															All Resets	
			31/15	30/14	29/13	28/12	27/11	26/10	25/9	24/8	23/7	22/6	21/5	20/4	19/3	18/2	17/1		16/0
6140	TRISF	31:16	—	—	—	—	—	—	—	—	—	—	—	—	—	—	—	—	0000
		15:0	—	—	TRISF13	TRISF12	—	—	—	TRISF8	—	—	TRISF5	TRISF4	TRISF3	TRISF2	TRISF1	TRISF0	313F
6150	PORTF	31:16	—	—	—	—	—	—	—	—	—	—	—	—	—	—	—	—	0000
		15:0	—	—	RF13	RF12	—	—	—	RF8	—	—	RF5	RF4	RF3	RF2	RF1	RF0	xxxx
6160	LATF	31:16	—	—	—	—	—	—	—	—	—	—	—	—	—	—	—	—	0000
		15:0	—	—	LATF13	LATF12	—	—	—	LATF8	—	—	LATF5	LATF4	LATF3	LATF2	LATF1	LATF0	xxxx
6170	ODCF	31:16	—	—	—	—	—	—	—	—	—	—	—	—	—	—	—	—	0000
		15:0	—	—	ODCF13	ODCF12	—	—	—	ODCF8	—	—	ODCF5	ODCF4	ODCF3	ODCF2	ODCF1	ODCF0	0000

**Legend:** x = unknown value on Reset; — = unimplemented, read as '0'. Reset values are shown in hexadecimal.

**Note 1:** All registers in this table have corresponding CLR, SET and INV registers at their virtual addresses, plus offsets of 0x4, 0x8 and 0xC, respectively. See Section 12.1.1 “CLR, SET and INV Registers” for more information.

**TABLE 4-34: PORTG REGISTER MAP FOR PIC32MX575F256H, PIC32MX575F512H, PIC32MX675F256H, PIC32MX675F512H, PIC32MX695F512H, PIC32MX775F256H, PIC32MX775F512H AND PIC32MX795F512H DEVICES<sup>(1)</sup>**

Virtual Address (BF88_#)	Register Name	Bit Range	Bits															All Resets	
			31/15	30/14	29/13	28/12	27/11	26/10	25/9	24/8	23/7	22/6	21/5	20/4	19/3	18/2	17/1		16/0
6180	TRISG	31:16	—	—	—	—	—	—	—	—	—	—	—	—	—	—	—	—	0000
		15:0	—	—	—	—	—	—	TRISG9	TRISG8	TRISG7	TRISG6	—	—	TRISG3	TRISG2	—	—	03CC
6190	PORTG	31:16	—	—	—	—	—	—	—	—	—	—	—	—	—	—	—	—	0000
		15:0	—	—	—	—	—	—	RG9	RG8	RG7	RG6	—	—	RG3	RG2	—	—	xxxx
61A0	LATG	31:16	—	—	—	—	—	—	—	—	—	—	—	—	—	—	—	—	0000
		15:0	—	—	—	—	—	—	LATG9	LATG8	LATG7	LATG6	—	—	LATG3	LATG2	—	—	xxxx
61B0	ODCG	31:16	—	—	—	—	—	—	—	—	—	—	—	—	—	—	—	—	0000
		15:0	—	—	—	—	—	—	ODCG9	ODCG8	ODCG7	ODCG6	—	—	ODCG3	ODCG2	—	—	0000

**Legend:** x = unknown value on Reset; — = unimplemented, read as '0'. Reset values are shown in hexadecimal.

**Note 1:** All registers in this table have corresponding CLR, SET and INV registers at their virtual addresses, plus offsets of 0x4, 0x8 and 0xC, respectively. See Section 12.1.1 “CLR, SET and INV Registers” for more information.

**TABLE 4-35: PORTG REGISTER MAP FOR PIC32MX575F256L, PIC32MX575F512L, PIC32MX675F256L, PIC32MX675F512L, PIC32MX695F512L, PIC32MX775F256L, PIC32MX775F512L AND PIC32MX795F512L DEVICES<sup>(1)</sup>**

Virtual Address (BF88_#)	Register Name	Bit Range	Bits															All Resets	
			31/15	30/14	29/13	28/12	27/11	26/10	25/9	24/8	23/7	22/6	21/5	20/4	19/3	18/2	17/1		16/0
6180	TRISG	31:16	—	—	—	—	—	—	—	—	—	—	—	—	—	—	—	—	0000
		15:0	TRISG15	TRISG14	TRISG13	TRISG12	—	—	TRISG9	TRISG8	TRISG7	TRISG6	—	—	TRISG3	TRISG2	TRISG1	TRISG0	F3CF
6190	PORTG	31:16	—	—	—	—	—	—	—	—	—	—	—	—	—	—	—	—	0000
		15:0	RG15	RG14	RG13	RG12	—	—	RG9	RG8	RG7	RG6	—	—	RG3	RG2	RG1	RG0	xxxx
61A0	LATG	31:16	—	—	—	—	—	—	—	—	—	—	—	—	—	—	—	—	0000
		15:0	LATG15	LATG14	LATG13	LATG12	—	—	LATG9	LATG8	LATG7	LATG6	—	—	LATG3	LATG2	LATG1	LATG0	xxxx
61B0	ODCG	31:16	—	—	—	—	—	—	—	—	—	—	—	—	—	—	—	—	0000
		15:0	ODCG15	ODCG14	ODCG13	ODCG12	—	—	ODCG9	ODCG8	ODCG7	ODCG6	—	—	ODCG3	ODCG2	ODCG1	ODCG0	0000

**Legend:** x = unknown value on Reset; — = unimplemented, read as '0'. Reset values are shown in hexadecimal.

**Note 1:** All registers in this table have corresponding CLR, SET and INV registers at their virtual addresses, plus offsets of 0x4, 0x8 and 0xC, respectively. See Section 12.1.1 “CLR, SET and INV Registers” for more information.

**TABLE 4-36: CHANGE NOTICE AND PULL-UP REGISTER MAP FOR PIC32MX575F256L, PIC32MX575F512L, PIC32MX675F256L, PIC32MX675F512L, PIC32MX695F512L, PIC32MX775F256L, PIC32MX775F512 AND PIC32MX795F512L DEVICES<sup>(1)</sup>**

Virtual Address (BF88_#)	Register Name	Bit Range	Bits																All Resets
			31/15	30/14	29/13	28/12	27/11	26/10	25/9	24/8	23/7	22/6	21/5	20/4	19/3	18/2	17/1	16/0	
61C0	CNCON	31:16	—	—	—	—	—	—	—	—	—	—	—	—	—	—	—	—	0000
		15:0	ON	FRZ	SIDL	—	—	—	—	—	—	—	—	—	—	—	—	—	0000
61D0	CNEN	31:16	—	—	—	—	—	—	—	—	—	—	CNEN21	CNEN20	CNEN19	CNEN18	CNEN17	CNEN16	0000
		15:0	CNEN15	CNEN14	CNEN13	CNEN12	CNEN11	CNEN10	CNEN9	CNEN8	CNEN7	CNEN6	CNEN5	CNEN4	CNEN3	CNEN2	CNEN1	CNEN0	0000
61E0	CNPUE	31:16	—	—	—	—	—	—	—	—	—	—	CNPUE21	CNPUE20	CNPUE19	CNPUE18	CNPUE17	CNPUE16	0000
		15:0	CNPUE15	CNPUE14	CNPUE13	CNPUE12	CNPUE11	CNPUE10	CNPUE9	CNPUE8	CNPUE7	CNPUE6	CNPUE5	CNPUE4	CNPUE3	CNPUE2	CNPUE1	CNPUE0	0000

**Legend:** x = unknown value on Reset; — = unimplemented, read as '0'. Reset values are shown in hexadecimal.

**Note 1:** All registers in this table have corresponding CLR, SET and INV registers at their virtual addresses, plus offsets of 0x4, 0x8 and 0xC, respectively. See Section 12.1.1 “CLR, SET and INV Registers” for more information.

**TABLE 4-37: CHANGE NOTICE AND PULL-UP REGISTER MAP FOR PIC32MX575F256H, PIC32MX575F512H, PIC32MX675F256H, PIC32MX675F512H, PIC32MX695F512H, PIC32MX775F256H, PIC32MX775F512H AND PIC32MX795F512H DEVICES<sup>(1)</sup>**

Virtual Address (BF88_#)	Register Name	Bit Range	Bits																All Resets
			31/15	30/14	29/13	28/12	27/11	26/10	25/9	24/8	23/7	22/6	21/5	20/4	19/3	18/2	17/1	16/0	
61C0	CNCON	31:16	—	—	—	—	—	—	—	—	—	—	—	—	—	—	—	—	0000
		15:0	ON	FRZ	SIDL	—	—	—	—	—	—	—	—	—	—	—	—	—	0000
61D0	CNEN	31:16	—	—	—	—	—	—	—	—	—	—	—	—	—	CNEN18	CNEN17	CNEN16	0000
		15:0	CNEN15	CNEN14	CNEN13	CNEN12	CNEN11	CNEN10	CNEN9	CNEN8	CNEN7	CNEN6	CNEN5	CNEN4	CNEN3	CNEN2	CNEN1	CNEN0	0000
61E0	CNPUE	31:16	—	—	—	—	—	—	—	—	—	—	—	—	—	CNPUE18	CNPUE17	CNPUE16	0000
		15:0	CNPUE15	CNPUE14	CNPUE13	CNPUE12	CNPUE11	CNPUE10	CNPUE9	CNPUE8	CNPUE7	CNPUE6	CNPUE5	CNPUE4	CNPUE3	CNPUE2	CNPUE1	CNPUE0	0000

**Legend:** x = unknown value on Reset; — = unimplemented, read as '0'. Reset values are shown in hexadecimal.

**Note 1:** All registers in this table have corresponding CLR, SET and INV registers at their virtual addresses, plus offsets of 0x4, 0x8 and 0xC, respectively. See Section 12.1.1 “CLR, SET and INV Registers” for more information.

**TABLE 4-38: PARALLEL MASTER PORT REGISTER MAP<sup>(1)</sup>**

Virtual Address (BF80_#)	Register Name	Bit Range	Bits															All Resets	
			31/15	30/14	29/13	28/12	27/11	26/10	25/9	24/8	23/7	22/6	21/5	20/4	19/3	18/2	17/1		16/0
7000	PMCON	31:16	—	—	—	—	—	—	—	—	—	—	—	—	—	—	—	—	0000
		15:0	ON	FRZ	SIDL	ADRMUX<1:0>			PMP TTL	PTWREN	PTRDEN	CSF<1:0>		ALP	CS2P	CS1P	—	WRSP	RDSP
7010	PMMODE	31:16	—	—	—	—	—	—	—	—	—	—	—	—	—	—	—	—	0000
		15:0	BUSY	IRQM<1:0>			INCM<1:0>			MODE16	MODE<1:0>		WAITB<1:0>			WAITM<3:0>		WAITE<1:0>	0000
7020	PMADDR	31:16	—	—	—	—	—	—	—	—	—	—	—	—	—	—	—	—	0000
		15:0	CS2EN/A15	CS1EN/A14	ADDR<13:0>													0000	
7030	PMDOUT	31:16	DATAOUT<31:0>															0000	
		15:0																0000	
7040	PMDIN	31:16	DATAIN<31:0>															0000	
		15:0																0000	
7050	PMAEN	31:16	—	—	—	—	—	—	—	—	—	—	—	—	—	—	—	—	0000
		15:0	PTEN<15:0>															0000	
7060	PMSTAT	31:16	—	—	—	—	—	—	—	—	—	—	—	—	—	—	—	—	0000
		15:0	IBF	IBOV	—	—	IB3F	IB2F	IB1F	IB0F	OBE	OBUF	—	—	OB3E	OB2E	OB1E	OB0E	0080

**Legend:** x = unknown value on Reset; — = unimplemented, read as '0'. Reset values are shown in hexadecimal.

**Note 1:** All registers in this table have corresponding CLR, SET and INV registers at their virtual addresses, plus offsets of 0x4, 0x8 and 0xC, respectively. See Section 12.1.1 "CLR, SET and INV Registers" for more information.

**TABLE 4-39: PROGRAMMING AND DIAGNOSTICS REGISTER MAP**

Virtual Address (BF80_#)	Register Name	Bit Range	Bits															All Resets	
			31/15	30/14	29/13	28/12	27/11	26/10	25/9	24/8	23/7	22/6	21/5	20/4	19/3	18/2	17/1		16/0
F200	DDPCON	31:16	—	—	—	—	—	—	—	—	—	—	—	—	—	—	—	—	0000
		15:0	—	—	—	—	—	—	—	—	—	—	—	—	—	JTAGEN	TROEN	—	TDOEN

**Legend:** x = unknown value on Reset; — = unimplemented, read as '0'. Reset values are shown in hexadecimal.

**TABLE 4-40: PREFETCH REGISTER MAP**

Virtual Address (BF88_#)	Register Name	Bit Range	Bits															All Resets	
			31/15	30/14	29/13	28/12	27/11	26/10	25/9	24/8	23/7	22/6	21/5	20/4	19/3	18/2	17/1		16/0
4000	CHECON <sup>(1,2)</sup>	31:16	—	—	—	—	—	—	—	—	—	—	—	—	—	—	—	CHECOH	0000
		15:0	—	—	—	—	—	—	DCSZ<1:0>	—	—	PREFEN<1:0>	—	—	—	—	—	PFMWS<2:0>	0000
4010	CHEACC <sup>(1)</sup>	31:16	CHEWEN	—	—	—	—	—	—	—	—	—	—	—	—	—	—	—	0000
		15:0	—	—	—	—	—	—	—	—	—	—	—	—	—	—	—	CHEIDX<3:0>	0000
4020	CHETAG <sup>(1)</sup>	31:16	LTAGBOOT	—	—	—	—	—	—	—	—	—	—	—	—	—	—	—	00xx
		15:0	—	—	—	—	—	—	—	—	—	—	—	—	—	—	—	—	LTAG<23:16>
4030	CHEMSK <sup>(1)</sup>	31:16	—	—	—	—	—	—	—	—	—	—	—	—	—	—	—	LVALID	0000
		15:0	—	—	—	—	—	—	—	—	—	—	—	—	—	—	—	—	LLOCK
4040	CHEW0	31:16	—	—	—	—	—	—	—	—	—	—	—	—	—	—	—	—	xxxx
		15:0	—	—	—	—	—	—	—	—	—	—	—	—	—	—	—	—	—
4050	CHEW1	31:16	—	—	—	—	—	—	—	—	—	—	—	—	—	—	—	—	xxxx
		15:0	—	—	—	—	—	—	—	—	—	—	—	—	—	—	—	—	—
4060	CHEW2	31:16	—	—	—	—	—	—	—	—	—	—	—	—	—	—	—	—	xxxx
		15:0	—	—	—	—	—	—	—	—	—	—	—	—	—	—	—	—	—
4070	CHEW3	31:16	—	—	—	—	—	—	—	—	—	—	—	—	—	—	—	—	xxxx
		15:0	—	—	—	—	—	—	—	—	—	—	—	—	—	—	—	—	—
4080	CHELRU	31:16	—	—	—	—	—	—	—	—	—	—	—	—	—	—	—	—	0000
		15:0	—	—	—	—	—	—	—	—	—	—	—	—	—	—	—	—	—
4090	CHEHIT	31:16	—	—	—	—	—	—	—	—	—	—	—	—	—	—	—	—	xxxx
		15:0	—	—	—	—	—	—	—	—	—	—	—	—	—	—	—	—	—
40A0	CHEMIS	31:16	—	—	—	—	—	—	—	—	—	—	—	—	—	—	—	—	xxxx
		15:0	—	—	—	—	—	—	—	—	—	—	—	—	—	—	—	—	—
40C0	CHEPFABT	31:16	—	—	—	—	—	—	—	—	—	—	—	—	—	—	—	—	xxxx
		15:0	—	—	—	—	—	—	—	—	—	—	—	—	—	—	—	—	—

**Legend:** x = unknown value on Reset; — = unimplemented, read as '0'. Reset values are shown in hexadecimal.

- Note** 1: This register has corresponding CLR, SET and INV registers at its virtual address, plus an offset of 0x4, 0x8 and 0xC, respectively. See Section 12.1.1 "CLR, SET and INV Registers" for more information.  
 2: Reset value is dependent on DEVCFGx configuration.

TABLE 4-41: RTCC REGISTER MAP<sup>(1)</sup>

Virtual Address (BF80_#)	Register Name	Bit Range	Bits															All Resets					
			31/15	30/14	29/13	28/12	27/11	26/10	25/9	24/8	23/7	22/6	21/5	20/4	19/3	18/2	17/1		16/0				
0200	RTCCON	31:16	—	—	—	—	—	—	CAL<9:0>									0000					
		15:0	ON	FRZ	SIDL	—	—	—	—	—	RTSECSEL	RTCCLKON	—	—	RTCWREN	RTCSYNC	HALFSEC	RTCOC	0000				
0210	RTCALRM	31:16	—	—	—	—	—	—	—	—	—	—	—	—	—	—	—	0000					
		15:0	ALRMEN	CHIME	PIV	ALRMSYNC	AMASK<3:0>					ARPT<7:0>							0000				
0220	RTCTIME	31:16	HR10<3:0>			HR01<3:0>			MIN10<3:0>					MIN01<3:0>					xxxx				
		15:0	SEC10<3:0>					SEC01<3:0>					—	—	—	—	—	—	—	—	xx00		
0230	RTCDATE	31:16	YEAR10<3:0>					YEAR01<3:0>					MONTH10<3:0>					MONTH01<3:0>					xxxx
		15:0	DAY10<3:0>					DAY01<3:0>					—	—	—	—	WDAY01<3:0>					xx00	
0240	ALRMTIME	31:16	HR10<3:0>			HR01<3:0>			MIN10<3:0>					MIN01<3:0>					xxxx				
		15:0	SEC10<3:0>					SEC01<3:0>					—	—	—	—	—	—	—	—	xx00		
0250	ALRMDATE	31:16	—	—	—	—	—	—	—	—	MONTH10<3:0>					MONTH01<3:0>					00xx		
		15:0	DAY10<3:0>					DAY01<3:0>					—	—	—	—	WDAY01<3:0>					xx0x	

**Legend:** x = unknown value on Reset; — = unimplemented, read as '0'. Reset values are shown in hexadecimal.

**Note 1:** All registers in this table have corresponding CLR, SET and INV registers at its virtual address, plus an offset of 0x4, 0x8 and 0xC, respectively. See Section 12.1.1 "CLR, SET and INV Registers" for more information.

**TABLE 4-42: DEVCFG: DEVICE CONFIGURATION WORD SUMMARY**

Virtual Address (BFC0_#)	Register Name	Bit Range	Bits														All Resets	
			31/15	30/14	29/13	28/12	27/11	26/10	25/9	24/8	23/7	22/6	21/5	20/4	19/3	18/2		17/1
2FF0	DEVCFG3	31:16	FVBUSIO	FUSBIDIO	FSCMIO	—	—	FCANIO	FETHIO	FMIEN	—	—	—	—	—	FSRSSEL<2:0>		xxxx
		15:0	USERID<15:0>														xxxx	
2FF4	DEVCFG2	31:16	—	—	—	—	—	—	—	—	—	—	—	—	—	FPLLODIV<2:0>		xxxx
		15:0	UPLLEN	—	—	—	—	UPLLDIV<2:0>			—	FPLLMULT<2:0>		—	FPLLDIV<2:0>		xxxx	
2FF8	DEVCFG1	31:16	—	—	—	—	—	—	—	FWDTEN	—	—	WDTPS<4:0>				xxxx	
		15:0	FCKSM<1:0>		FPBDIV<1:0>		—	OSCIOFNC	POSCMOD<1:0>		IESO	—	FSOSCEN	—	—	FNOSC<2:0>		xxxx
2FFC	DEVCFG0	31:16	—	—	—	CP	—	—	—	BWP	—	—	—	—	PWP<7:4>			xxxx
		15:0	PWP<3:0>			—	—	—	—	—	—	—	—	—	ICESEL	—	DEBUG<1:0>	

**Legend:** x = unknown value on Reset; — = unimplemented, read as '0'. Reset values are shown in hexadecimal.

**TABLE 4-43: DEVICE AND REVISION ID SUMMARY<sup>(1)</sup>**

Virtual Address (BF80_#)	Register Name	Bit Range	Bits														All Resets		
			31/15	30/14	29/13	28/12	27/11	26/10	25/9	24/8	23/7	22/6	21/5	20/4	19/3	18/2		17/1	16/0
F220	DEVID	31:16	VER<3:0>					DEVID<27:16>											xxxx
		15:0	DEVID<15:0>														xxxx		

**Legend:** x = unknown value on Reset; — = unimplemented, read as '0'. Reset values are shown in hexadecimal.

**Note 1:** Reset values are dependent on the device variant. Refer to the "PIC32MX5XX/6XX/7XX Family Silicon Errata and Data Sheet Clarification" (DS80480) for more information.

TABLE 4-44: USB REGISTER MAP

Virtual Address (BF88_#)	Register Name	Bit Range	Bits															All Resets	
			31/15	30/14	29/13	28/12	27/11	26/10	25/9	24/8	23/7	22/6	21/5	20/4	19/3	18/2	17/1		16/0
5040	U1OTGIR	31:16	—	—	—	—	—	—	—	—	—	—	—	—	—	—	—	—	0000
		15:0	—	—	—	—	—	—	—	—	IDIF	T1MSECIF	LSTATEIF	ACTVIF	SESVDIF	SESENDIF	—	VBUSVDIF	0000
5050	U1OTGIE	31:16	—	—	—	—	—	—	—	—	—	—	—	—	—	—	—	0000	
		15:0	—	—	—	—	—	—	—	—	IDIE	T1MSECIE	LSTATEIE	ACTVIE	SESVDIE	SESENDIE	—	VBUSVDIE	0000
5060	U1OTGSTAT	31:16	—	—	—	—	—	—	—	—	—	—	—	—	—	—	—	0000	
		15:0	—	—	—	—	—	—	—	—	ID	—	LSTATE	—	SESVD	SESEND	—	VBUSVD	0000
5070	U1OTGCON	31:16	—	—	—	—	—	—	—	—	—	—	—	—	—	—	—	0000	
		15:0	—	—	—	—	—	—	—	—	DPPULUP	DMPULUP	DPPULDWN	DMPULDWN	VBUSON	OTGEN	VBUSCHG	VBUSDIS	0000
5080	U1PWRC	31:16	—	—	—	—	—	—	—	—	—	—	—	—	—	—	—	0000	
		15:0	—	—	—	—	—	—	—	—	UACTPND <sup>(1)</sup>	—	—	USLPGRD	USBBUSY	—	USUSPEND	USBPWR	0000
5200	U1IR	31:16	—	—	—	—	—	—	—	—	—	—	—	—	—	—	—	0000	
		15:0	—	—	—	—	—	—	—	—	STALLIF	ATTACHIF	RESUMEIF	IDLEIF	TRNIF	SOFIF	UERRIF	URSTIF	DETACHIF
5210	U1IE	31:16	—	—	—	—	—	—	—	—	—	—	—	—	—	—	—	0000	
		15:0	—	—	—	—	—	—	—	—	STALLIE	ATTACHIE	RESUMEIE	IDLEIE	TRNIE	SOFIE	UERRIE	URSTIE	DETACHIE
5220	U1EIR	31:16	—	—	—	—	—	—	—	—	—	—	—	—	—	—	—	0000	
		15:0	—	—	—	—	—	—	—	—	BTSEF	BMXEF	DMAEF	BTOEF	DFN8EF	CRC16EF	CRC5EF	EOFEF	PIDEF
5230	U1EIE	31:16	—	—	—	—	—	—	—	—	—	—	—	—	—	—	—	0000	
		15:0	—	—	—	—	—	—	—	—	BTSEE	BMXEE	DMAEE	BTOEE	DFN8EE	CRC16EE	CRC5EE	EOFEE	PIDEE
5240	U1STAT	31:16	—	—	—	—	—	—	—	—	—	—	—	—	—	—	—	0000	
		15:0	—	—	—	—	—	—	—	—	—	ENDPT<3:0>			DIR	PPBI	—	—	0000
5250	U1CON	31:16	—	—	—	—	—	—	—	—	—	—	—	—	—	—	—	0000	
		15:0	—	—	—	—	—	—	—	—	JSTATE	SE0	PKTDIS	TOKBUSY	USBRST	HOSTEN	RESUME	PPBRST	USBEN
5260	U1ADDR	31:16	—	—	—	—	—	—	—	—	—	—	—	—	—	—	—	0000	
		15:0	—	—	—	—	—	—	—	—	LSPDEN	DEVADDR<6:0>							0000
5270	U1BDTP1	31:16	—	—	—	—	—	—	—	—	—	—	—	—	—	—	—	0000	
		15:0	—	—	—	—	—	—	—	—	—	BDTPTRL<7:1>							0000
5280	U1FRML	31:16	—	—	—	—	—	—	—	—	—	—	—	—	—	—	—	0000	
		15:0	—	—	—	—	—	—	—	—	—	FRML<7:0>							0000
5290	U1FRMH	31:16	—	—	—	—	—	—	—	—	—	—	—	—	—	—	—	0000	
		15:0	—	—	—	—	—	—	—	—	—	FRMH<2:0>							0000
52A0	U1TOK	31:16	—	—	—	—	—	—	—	—	—	—	—	—	—	—	—	0000	
		15:0	—	—	—	—	—	—	—	—	—	PID<3:0>				EP<3:0>			

**Legend:** x = unknown value on Reset; — = unimplemented, read as '0'. Reset values are shown in hexadecimal.

**Note 1:** Reset value for this bit is undefined.



**TABLE 4-44: USB REGISTER MAP (CONTINUED)**

Virtual Address (BF68_#)	Register Name	Bit Range	Bits															All Resets		
			31/15	30/14	29/13	28/12	27/11	26/10	25/9	24/8	23/7	22/6	21/5	20/4	19/3	18/2	17/1		16/0	
52B0	U1SOF	31:16	—	—	—	—	—	—	—	—	—	—	—	—	—	—	—	—	0000	
		15:0	—	—	—	—	—	—	—	—	CNT<7:0>							—	—	—
52C0	U1BDTP2	31:16	—	—	—	—	—	—	—	—	—	—	—	—	—	—	—	—	0000	
		15:0	—	—	—	—	—	—	—	—	BDTPTRH<7:0>							—	—	—
52D0	U1BDTP3	31:16	—	—	—	—	—	—	—	—	—	—	—	—	—	—	—	—	0000	
		15:0	—	—	—	—	—	—	—	—	BDTPTRU<7:0>							—	—	—
52E0	U1CNFG1	31:16	—	—	—	—	—	—	—	—	—	—	—	—	—	—	—	—	0000	
		15:0	—	—	—	—	—	—	—	—	UTEYE	UOEMON	USBFRZ	USBSIDL	—	—	—	—	UASUSPND	0001
5300	U1EP0	31:16	—	—	—	—	—	—	—	—	—	—	—	—	—	—	—	—	0000	
		15:0	—	—	—	—	—	—	—	—	LSPD	RETRYDIS	—	EPCONDIS	EPRXEN	EPTXEN	EPSTALL	EPHSHK	0000	
5310	U1EP1	31:16	—	—	—	—	—	—	—	—	—	—	—	—	—	—	—	—	0000	
		15:0	—	—	—	—	—	—	—	—	—	—	—	EPCONDIS	EPRXEN	EPTXEN	EPSTALL	EPHSHK	0000	
5320	U1EP2	31:16	—	—	—	—	—	—	—	—	—	—	—	—	—	—	—	—	0000	
		15:0	—	—	—	—	—	—	—	—	—	—	—	EPCONDIS	EPRXEN	EPTXEN	EPSTALL	EPHSHK	0000	
5330	U1EP3	31:16	—	—	—	—	—	—	—	—	—	—	—	—	—	—	—	—	0000	
		15:0	—	—	—	—	—	—	—	—	—	—	—	EPCONDIS	EPRXEN	EPTXEN	EPSTALL	EPHSHK	0000	
5340	U1EP4	31:16	—	—	—	—	—	—	—	—	—	—	—	—	—	—	—	—	0000	
		15:0	—	—	—	—	—	—	—	—	—	—	—	EPCONDIS	EPRXEN	EPTXEN	EPSTALL	EPHSHK	0000	
5350	U1EP5	31:16	—	—	—	—	—	—	—	—	—	—	—	—	—	—	—	—	0000	
		15:0	—	—	—	—	—	—	—	—	—	—	—	EPCONDIS	EPRXEN	EPTXEN	EPSTALL	EPHSHK	0000	
5360	U1EP6	31:16	—	—	—	—	—	—	—	—	—	—	—	—	—	—	—	—	0000	
		15:0	—	—	—	—	—	—	—	—	—	—	—	EPCONDIS	EPRXEN	EPTXEN	EPSTALL	EPHSHK	0000	
5370	U1EP7	31:16	—	—	—	—	—	—	—	—	—	—	—	—	—	—	—	—	0000	
		15:0	—	—	—	—	—	—	—	—	—	—	—	EPCONDIS	EPRXEN	EPTXEN	EPSTALL	EPHSHK	0000	
5380	U1EP8	31:16	—	—	—	—	—	—	—	—	—	—	—	—	—	—	—	—	0000	
		15:0	—	—	—	—	—	—	—	—	—	—	—	EPCONDIS	EPRXEN	EPTXEN	EPSTALL	EPHSHK	0000	
5390	U1EP9	31:16	—	—	—	—	—	—	—	—	—	—	—	—	—	—	—	—	0000	
		15:0	—	—	—	—	—	—	—	—	—	—	—	EPCONDIS	EPRXEN	EPTXEN	EPSTALL	EPHSHK	0000	
53A0	U1EP10	31:16	—	—	—	—	—	—	—	—	—	—	—	—	—	—	—	—	0000	
		15:0	—	—	—	—	—	—	—	—	—	—	—	EPCONDIS	EPRXEN	EPTXEN	EPSTALL	EPHSHK	0000	
53B0	U1EP11	31:16	—	—	—	—	—	—	—	—	—	—	—	—	—	—	—	—	0000	
		15:0	—	—	—	—	—	—	—	—	—	—	—	EPCONDIS	EPRXEN	EPTXEN	EPSTALL	EPHSHK	0000	
53C0	U1EP12	31:16	—	—	—	—	—	—	—	—	—	—	—	—	—	—	—	—	0000	
		15:0	—	—	—	—	—	—	—	—	—	—	—	EPCONDIS	EPRXEN	EPTXEN	EPSTALL	EPHSHK	0000	
53D0	U1EP13	31:16	—	—	—	—	—	—	—	—	—	—	—	—	—	—	—	—	0000	
		15:0	—	—	—	—	—	—	—	—	—	—	—	EPCONDIS	EPRXEN	EPTXEN	EPSTALL	EPHSHK	0000	

**Legend:** × = unknown value on Reset; — = unimplemented, read as '0'. Reset values are shown in hexadecimal.

**Note 1:** Reset value for this bit is undefined.

**TABLE 4-44: USB REGISTER MAP (CONTINUED)**

Virtual Address (BF88_#)	Register Name	Bit Range	Bits																All Resets
			31/15	30/14	29/13	28/12	27/11	26/10	25/9	24/8	23/7	22/6	21/5	20/4	19/3	18/2	17/1	16/0	
53E0	U1EP14	31:16	—	—	—	—	—	—	—	—	—	—	—	—	—	—	—	—	0000
		15:0	—	—	—	—	—	—	—	—	—	—	—	—	EPCONDIS	EPRXEN	EPTXEN	EPSTALL	EPHSHK
53F0	U1EP15	31:16	—	—	—	—	—	—	—	—	—	—	—	—	—	—	—	—	0000
		15:0	—	—	—	—	—	—	—	—	—	—	—	—	EPCONDIS	EPRXEN	EPTXEN	EPSTALL	EPHSHK

**Legend:** x = unknown value on Reset; — = unimplemented, read as '0'. Reset values are shown in hexadecimal.

**Note 1:** Reset value for this bit is undefined.

**TABLE 4-45: CAN1 REGISTER SUMMARY FOR PIC32MX575F256H, PIC32MX575F512H, PIC32MX775F256H, PIC32MX775F512H, PIC32MX795F512H, PIC32MX575F256L, PIC32MX575F512L, PIC32MX775F256L, PIC32MX775F512L AND PIC32MX795F512L DEVICES<sup>(1)</sup>**

Virtual Address (BF88_#)	Register Name	Bit Range	Bits														All Resets			
			31/15	30/14	29/13	28/12	27/11	26/10	25/9	24/8	23/7	22/6	21/5	20/4	19/3	18/2		17/1	16/0	
B000	C1CON	31:16	—	—	—	—	ABAT	REQOP<2:0>				OPMOD<2:0>			CANCAP	—	—	—	—	0400
		15:0	ON	—	SIDLE	—	BUSY	—	—	—	—	—	—	—	DNCNT<4:0>				0000	
B010	C1CFG	31:16	—	—	—	—	—	—	—	—	—	WAKFIL	—	—	—	—	—	—	0000	
		15:0	SEG2PHTS	SAM	SEG1PH<2:0>				PRSEG<2:0>			SJW<1:0>		BRP<5:0>					0000	
B020	C1INT	31:16	IVRIE	WAKIE	CERRIE	SERRIE	RBOVIE	—	—	—	—	—	—	—	MODIE	CTMRIE	RBIE	TBIE	0000	
		15:0	IVRIF	WAKIF	CERRIF	SERRIF	RBOVIF	—	—	—	—	—	—	—	—	MODIF	CTMRIF	RBIF	TBIF	0000
B030	C1VEC	31:16	—	—	—	—	—	—	—	—	—	—	—	—	—	—	—	—	0000	
		15:0	—	—	—	—	—	—	—	—	—	—	—	—	—	—	—	—	—	0000
B040	C1TREC	31:16	—	—	—	—	—	—	—	—	—	—	—	—	—	—	—	—	0000	
		15:0	TEC<7:0>							REC<7:0>							0000			
B050	C1FSTAT	31:16	FIFOIP31	FIFOIP30	FIFOIP29	FIFOIP28	FIFOIP27	FIFOIP26	FIFOIP25	FIFOIP24	FIFOIP23	FIFOIP22	FIFOIP21	FIFOIP20	FIFOIP19	FIFOIP18	FIFOIP17	FIFOIP16	0000	
		15:0	FIFOIP15	FIFOIP14	FIFOIP13	FIFOIP12	FIFOIP11	FIFOIP10	FIFOIP9	FIFOIP8	FIFOIP7	FIFOIP6	FIFOIP5	FIFOIP4	FIFOIP3	FIFOIP2	FIFOIP1	FIFOIP0	0000	
B060	C1RXOVF	31:16	RXOVF31	RXOVF30	RXOVF29	RXOVF28	RXOVF27	RXOVF26	RXOVF25	RXOVF24	RXOVF23	RXOVF22	RXOVF21	RXOVF20	RXOVF19	RXOVF18	RXOVF17	RXOVF16	0000	
		15:0	RXOVF15	RXOVF14	RXOVF13	RXOVF12	RXOVF11	RXOVF10	RXOVF9	RXOVF8	RXOVF7	RXOVF6	RXOVF5	RXOVF4	RXOVF3	RXOVF2	RXOVF1	RXOVF0	0000	
B070	C1TMR	31:16	CANTS<15:0>																0000	
		15:0	CANTSPRE<15:0>																0000	
B080	C1RXM0	31:16	SID<10:0>										—	MIDE	—	EID<17:16>			xxxx	
		15:0	EID<15:0>																xxxx	
B090	C1RXM1	31:16	SID<10:0>										—	MIDE	—	EID<17:16>			xxxx	
		15:0	EID<15:0>																xxxx	
B0A0	C1RXM2	31:16	SID<10:0>										—	MIDE	—	EID<17:16>			xxxx	
		15:0	EID<15:0>																xxxx	
B0B0	C1RXM3	31:16	SID<10:0>										—	MIDE	—	EID<17:16>			xxxx	
		15:0	EID<15:0>																xxxx	
B0C0	C1FLTCON0	31:16	FLTEN3	MSEL3<1:0>				FSEL3<4:0>				FLTEN2	MSEL2<1:0>			FSEL2<4:0>				0000
		15:0	FLTEN1	MSEL1<1:0>				FSEL1<4:0>				FLTEN0	MSEL0<1:0>			FSEL0<4:0>				0000
B0D0	C1FLTCON1	31:16	FLTEN7	MSEL7<1:0>				FSEL7<4:0>				FLTEN6	MSEL6<1:0>			FSEL6<4:0>				0000
		15:0	FLTEN5	MSEL5<1:0>				FSEL5<4:0>				FLTEN4	MSEL4<1:0>			FSEL4<4:0>				0000
B0E0	C1FLTCON2	31:16	FLTEN11	MSEL11<1:0>				FSEL11<4:0>				FLTEN10	MSEL10<1:0>			FSEL10<4:0>				0000
		15:0	FLTEN9	MSEL9<1:0>				FSEL9<4:0>				FLTEN8	MSEL8<1:0>			FSEL8<4:0>				0000
B0F0	C1FLTCON3	31:16	FLTEN15	MSEL15<1:0>				FSEL15<4:0>				FLTEN14	MSEL14<1:0>			FSEL14<4:0>				0000
		15:0	FLTEN13	MSEL13<1:0>				FSEL13<4:0>				FLTEN12	MSEL12<1:0>			FSEL12<4:0>				0000
B100	C1FLTCON4	31:16	FLTEN19	MSEL19<1:0>				FSEL19<4:0>				FLTEN18	MSEL18<1:0>			FSEL18<4:0>				0000
		15:0	FLTEN17	MSEL17<1:0>				FSEL17<4:0>				FLTEN16	MSEL16<1:0>			FSEL16<4:0>				0000

**Legend:** x = unknown value on Reset; — = unimplemented, read as '0'. Reset values are shown in hexadecimal.

**Note 1:** All registers in this table have corresponding CLR, SET and INV registers at their virtual addresses, plus offsets of 0x4, 0x8 and 0xC, respectively. See Section 12.1.1 "CLR, SET and INV Registers" for more information.

**TABLE 4-45: CAN1 REGISTER SUMMARY FOR PIC32MX575F256H, PIC32MX575F512H, PIC32MX775F256H, PIC32MX775F512H, PIC32MX795F512H, PIC32MX575F256L, PIC32MX575F512L, PIC32MX775F256L, PIC32MX775F512L AND PIC32MX795F512L DEVICES<sup>(1)</sup> (CONTINUED)**

Virtual Address (BF88_#)	Register Name	Bit Range	Bits															All Resets	
			31/15	30/14	29/13	28/12	27/11	26/10	25/9	24/8	23/7	22/6	21/5	20/4	19/3	18/2	17/1		16/0
B110	C1FLTCON5	31:16	FLTEN23	MSEL23<1:0>					FSEL23<4:0>		FLTEN22	MSEL22<1:0>			FSEL22<4:0>			0000	
		15:0	FLTEN21	MSEL21<1:0>					FSEL21<4:0>		FLTEN20	MSEL20<1:0>			FSEL20<4:0>			0000	
B120	C1FLTCON6	31:16	FLTEN27	MSEL27<1:0>					FSEL27<4:0>		FLTEN26	MSEL26<1:0>			FSEL26<4:0>			0000	
		15:0	FLTEN25	MSEL25<1:0>					FSEL25<4:0>		FLTEN24	MSEL24<1:0>			FSEL24<4:0>			0000	
B130	C1FLTCON7	31:16	FLTEN31	MSEL31<1:0>					FSEL31<4:0>		FLTEN30	MSEL30<1:0>			FSEL30<4:0>			0000	
		15:0	FLTEN29	MSEL29<1:0>					FSEL29<4:0>		FLTEN28	MSEL28<1:0>			FSEL28<4:0>			0000	
B140	C1RXFn (n = 0-31)	31:16							SID<10:0>					—	EXID	—	EID<17:16>	xxxx	
		15:0																EID<15:0>	xxxx
B340	C1FIFOBA	31:16																0000	
		15:0																C1FIFOBA<31:0>	0000
B350	C1FIFOCONn (n = 0-31)	31:16	—	—	—	—	—	—	—	—	—	—	—				FSIZE<4:0>	0000	
		15:0	—	FRESET	UINC	DONLY	—	—	—	—	TXEN	TXABAT	TXLARB	TXERR	TXREQ	RTREN	TXPRI<1:0>	0000	
B360	C1FIFOINTn (n = 0-31)	31:16	—	—	—	—	—	TXNFULLIE	TXHALFIE	TXEMPTYIE	—	—	—	—	RXOVFLIE	RXFULLIE	RXHALFIE	RXN EMPTYIE	0000
		15:0	—	—	—	—	—	TXNFULLIF	TXHALFIF	TXEMPTYIF	—	—	—	—	RXOVFLIF	RXFULLIF	RXHALFIF	RXN EMPTYIF	0000
B370	C1FIFOUAN (n = 0-31)	31:16																0000	
		15:0																C1FIFOUA<31:0>	0000
B380	C1FIFOCln (n = 0-31)	31:16	—	—	—	—	—	—	—	—	—	—	—	—	—	—	—	0000	
		15:0	—	—	—	—	—	—	—	—	—	—	—	—	—	—	—	C1FIFOCl<4:0>	0000

**Legend:** x = unknown value on Reset; — = unimplemented, read as '0'. Reset values are shown in hexadecimal.

**Note 1:** All registers in this table have corresponding CLR, SET and INV registers at their virtual addresses, plus offsets of 0x4, 0x8 and 0xC, respectively. See Section 12.1.1 "CLR, SET and INV Registers" for more information.

**TABLE 4-46: CAN2 REGISTER SUMMARY FOR PIC32MX775F256H, PIC32MX775F512H, PIC32MX795F512H, PIC32MX775F256L, PIC32MX775F512L AND PIC32MX795F512L DEVICES<sup>(1)</sup>**

Virtual Address (BF88_#)	Register Name	Bit Range	Bits														All Resets			
			31/15	30/14	29/13	28/12	27/11	26/10	25/9	24/8	23/7	22/6	21/5	20/4	19/3	18/2		17/1	16/0	
C000	C2CON	31:16	—	—	—	—	ABAT	REQOP<2:0>				OPMOD<2:0>			CANCAP	—	—	—	—	0400
		15:0	ON	—	SIDLE	—	BUSY	—	—	—	—	—	—	—	DNCNT<4:0>				0000	
C010	C2CFG	31:16	—	—	—	—	—	—	—	—	—	WAKFIL	—	—	—	—	SEG2PH<2:0>			0000
		15:0	SEG2PHTS	SAM	SEG1PH<2:0>				PRSEG<2:0>			SJW<1:0>		BRP<5:0>					0000	
C020	C2INT	31:16	IVRIE	WAKIE	CERRIE	SERRIE	RBOVIE	—	—	—	—	—	—	MODIE	CTMRIE	RBIE	TBIE	0000		
		15:0	IVRIF	WAKIF	CERRIF	SERRIF	RBOVIF	—	—	—	—	—	—	MODIF	CTMRIF	RBIF	TBIF	0000		
C030	C2VEC	31:16	—	—	—	—	—	—	—	—	—	—	—	—	—	—	—	0000		
		15:0	—	—	—	FILHIT<4:0>				—	ICOD<6:0>					0000				
C040	C2TREC	31:16	—	—	—	—	—	—	—	—	—	—	—	TXBO	TXBP	RXBP	TXWARN	RXWARN	EWARN	0000
		15:0	TEC<7:0>							REC<7:0>										0000
C050	C2FSTAT	31:16	FIFOIP31	FIFOIP30	FIFOIP29	FIFOIP28	FIFOIP27	FIFOIP26	FIFOIP25	FIFOIP24	FIFOIP23	FIFOIP22	FIFOIP21	FIFOIP20	FIFOIP19	FIFOIP18	FIFOIP17	FIFOIP16	0000	
		15:0	FIFOIP15	FIFOIP14	FIFOIP13	FIFOIP12	FIFOIP11	FIFOIP10	FIFOIP9	FIFOIP8	FIFOIP7	FIFOIP6	FIFOIP5	FIFOIP4	FIFOIP3	FIFOIP2	FIFOIP1	FIFOIP0	0000	
C060	C2RXOVF	31:16	RXOVF31	RXOVF30	RXOVF29	RXOVF28	RXOVF27	RXOVF26	RXOVF25	RXOVF24	RXOVF23	RXOVF22	RXOVF21	RXOVF20	RXOVF19	RXOVF18	RXOVF17	RXOVF16	0000	
		15:0	RXOVF15	RXOVF14	RXOVF13	RXOVF12	RXOVF11	RXOVF10	RXOVF9	RXOVF8	RXOVF7	RXOVF6	RXOVF5	RXOVF4	RXOVF3	RXOVF2	RXOVF1	RXOVF0	0000	
C070	C2TMR	31:16	CANTS<15:0>														0000			
		15:0	CANTSPRE<15:0>														0000			
C080	C2RXM0	31:16	SID<10:0>							—	MIDE	—	EID<17:16>					xxxx		
		15:0	EID<15:0>														xxxx			
C0A0	C2RXM1	31:16	SID<10:0>							—	MIDE	—	EID<17:16>					xxxx		
		15:0	EID<15:0>														xxxx			
C0B0	C2RXM2	31:16	SID<10:0>							—	MIDE	—	EID<17:16>					xxxx		
		15:0	EID<15:0>														xxxx			
C0B0	C2RXM3	31:16	SID<10:0>							—	MIDE	—	EID<17:16>					xxxx		
		15:0	EID<15:0>														xxxx			
C0C0	C2FLTCON0	31:16	FLTEN3	MSEL3<1:0>				FSEL3<4:0>				FLTEN2	MSEL2<1:0>		FSEL2<4:0>				0000	
		15:0	FLTEN1	MSEL1<1:0>				FSEL1<4:0>				FLTEN0	MSEL0<1:0>		FSEL0<4:0>				0000	
C0D0	C2FLTCON1	31:16	FLTEN7	MSEL7<1:0>				FSEL7<4:0>				FLTEN6	MSEL6<1:0>		FSEL6<4:0>				0000	
		15:0	FLTEN5	MSEL5<1:0>				FSEL5<4:0>				FLTEN4	MSEL4<1:0>		FSEL4<4:0>				0000	
C0E0	C2FLTCON2	31:16	FLTEN11	MSEL11<1:0>				FSEL11<4:0>				FLTEN10	MSEL10<1:0>		FSEL10<4:0>				0000	
		15:0	FLTEN9	MSEL9<1:0>				FSEL9<4:0>				FLTEN8	MSEL8<1:0>		FSEL8<4:0>				0000	
C0F0	C2FLTCON3	31:16	FLTEN15	MSEL15<1:0>				FSEL15<4:0>				FLTEN14	MSEL14<1:0>		FSEL14<4:0>				0000	
		15:0	FLTEN13	MSEL13<1:0>				FSEL13<4:0>				FLTEN12	MSEL12<1:0>		FSEL12<4:0>				0000	

**Legend:** x = unknown value on Reset; — = unimplemented, read as '0'. Reset values are shown in hexadecimal.  
**Note 1:** All registers in this table have corresponding CLR, SET and INV registers at their virtual addresses, plus offsets of 0x4, 0x8 and 0xC, respectively. See Section 12.1.1 “CLR, SET and INV Registers” for more information.

**TABLE 4-46: CAN2 REGISTER SUMMARY FOR PIC32MX775F256H, PIC32MX775F512H, PIC32MX795F512H, PIC32MX775F256L, PIC32MX775F512L AND PIC32MX795F512L DEVICES<sup>(1)</sup> (CONTINUED)**

Virtual Address (BF88_#)	Register Name	Bit Range	Bits														All Resets		
			31/15	30/14	29/13	28/12	27/11	26/10	25/9	24/8	23/7	22/6	21/5	20/4	19/3	18/2		17/1	16/0
C100	C2FLTCON4	31:16	FLTEN19	MSEL19<1:0>	FSEL19<4:0>				FLTEN18	MSEL18<1:0>	FSEL18<4:0>				0000				
		15:0	FLTEN17	MSEL17<1:0>	FSEL17<4:0>				FLTEN16	MSEL16<1:0>	FSEL16<4:0>				0000				
C110	C2FLTCON5	31:16	FLTEN23	MSEL23<1:0>	FSEL23<4:0>				FLTEN22	MSEL22<1:0>	FSEL22<4:0>				0000				
		15:0	FLTEN21	MSEL21<1:0>	FSEL21<4:0>				FLTEN20	MSEL20<1:0>	FSEL20<4:0>				0000				
C120	C2FLTCON6	31:16	FLTEN27	MSEL27<1:0>	FSEL27<4:0>				FLTEN26	MSEL26<1:0>	FSEL26<4:0>				0000				
		15:0	FLTEN25	MSEL25<1:0>	FSEL25<4:0>				FLTEN24	MSEL24<1:0>	FSEL24<4:0>				0000				
C130	C2FLTCON7	31:16	FLTEN31	MSEL31<1:0>	FSEL31<4:0>				FLTEN30	MSEL30<1:0>	FSEL30<4:0>				0000				
		15:0	FLTEN29	MSEL29<1:0>	FSEL29<4:0>				FLTEN28	MSEL28<1:0>	FSEL28<4:0>				0000				
C140	C2RXFn (n = 0-31)	31:16	SID<10:0>										—	EXID	—	EID<17:16>	xxxx		
		15:0	EID<15:0>														xxxx		
C340	C2FIFOBA	31:16	C2FIFOBA<31:0>														0000		
		15:0	C2FIFOBA<31:0>														0000		
C350	C2FIFOCOn (n = 0-31)	31:16	—	—	—	—	—	—	—	—	—	—	FSIZE<4:0>				0000		
		15:0	—	FRESET	UINC	DONLY	—	—	—	TXEN	TXABAT	TXLARB	TXERR	TXREQ	RTREN	TXPRI<1:0>		0000	
C360	C2FIFOINTn (n = 0-31)	31:16	—	—	—	—	—	TXNFULLIE	TXHALFIE	TXEMPTYIE	—	—	—	—	RXOVFLIE	RXFULLIE	RXHALFIE	RXN EMPTYIE	0000
		15:0	—	—	—	—	—	TXNFULLIF	TXHALFIF	TXEMPTYIF	—	—	—	—	RXOVFLIF	RXFULLIF	RXHALFIF	RXN EMPTYIF	0000
C370	C2FIFOUAn (n = 0-31)	31:16	C2FIFOUA<31:0>														0000		
		15:0	C2FIFOUA<31:0>														0000		
C380	C2FIFOCIn (n = 0-31)	31:16	—	—	—	—	—	—	—	—	—	—	—	—	—	—	—	—	0000
		15:0	—	—	—	—	—	—	—	—	—	—	—	C2FIFOCIn<4:0>				0000	

**Legend:** x = unknown value on Reset; — = unimplemented, read as '0'. Reset values are shown in hexadecimal.

**Note 1:** All registers in this table have corresponding CLR, SET and INV registers at their virtual addresses, plus offsets of 0x4, 0x8 and 0xC, respectively. See Section 12.1.1 "CLR, SET and INV Registers" for more information.

**TABLE 4-47: ETHERNET CONTROLLER REGISTER SUMMARY FOR PIC32MX675F256H, PIC32MX675F512H, PIC32MX695F512H, PIC32MX775F256H, PIC32MX775F512H, PIC32MX795F512H, PIC32MX695F512L, PIC32MX675F256L, PIC32MX675F512L, PIC32MX775F256L, PIC32MX775F512L AND PIC32MX795F512L DEVICES<sup>(1)</sup>**

Virtual Address (BF88_#)	Register Name	Bit Range	Bits															All Resets		
			31/15	30/14	29/13	28/12	27/11	26/10	25/9	24/8	23/7	22/6	21/5	20/4	19/3	18/2	17/1		16/0	
9000	ETHCON1	31:16	PTV<15:0>															0000		
		15:0	ON	FRZ	SIDL	—	—	—	—	TXRTS	RXEN	AUTOFC	—	—	MANFC	—	—	—	—	BUFCDEC
9010	ETHCON2	31:16	—	—	—	—	—	—	—	—	—	—	—	—	—	—	—	—	—	0000
		15:0	—	—	—	—	—	—	RXBUFSZ<6:0>							—	—	—	—	0000
9020	ETHTXST	31:16	TXSTADDR<31:16>															0000		
		15:0	TXSTADDR<15:2>												—	—	0000			
9030	ETHRXST	31:16	RXSTADDR<31:16>															0000		
		15:0	RXSTADDR<15:2>												—	—	0000			
9040	ETHHT0	31:16	HT<31:0>															0000		
		15:0																0000		
9050	ETHHT1	31:16	HT<63:32>															0000		
		15:0																0000		
9060	ETHPMM0	31:16	PMM<31:0>															0000		
		15:0																0000		
9070	ETHPMM1	31:16	PMM<63:32>															0000		
		15:0																0000		
9080	ETHPMCS	31:16	—	—	—	—	—	—	—	—	—	—	—	—	—	—	—	—	—	0000
		15:0	PMCS<15:0>															0000		
9090	ETHPMO	31:16	—	—	—	—	—	—	—	—	—	—	—	—	—	—	—	—	—	0000
		15:0	PMO<15:0>															0000		
90A0	ETHRXFC	31:16	—	—	—	—	—	—	—	—	—	—	—	—	—	—	—	—	—	0000
		15:0	HTEN	MPEN	—	NOTPM	PMMODE<3:0>				CRC ERREN	CRC OKEN	RUNT ERREN	RUNTEN	UCEN	NOT MEEN	MCEN	BCEN	0000	
90B0	ETHRXWM	31:16	—	—	—	—	—	—	—	—	—	—	—	—	—	—	—	—	—	0000
		15:0	—	—	—	—	—	—	—	—	RXFWM<7:0>							0000		
90C0	ETHIEN	31:16	—	—	—	—	—	—	—	—	—	—	—	—	—	—	—	—	—	0000
		15:0	—	TX BUSEIE	RX BUSEIE	—	—	—	EW MARKIE	FW MARKIE	RX DONEIE	PK TPENDIE	RX ACTIE	—	TX DONEIE	TX ABORTIE	RX BUFNAIE	RX OVFLWIE	0000	
90D0	ETHIRQ	31:16	—	—	—	—	—	—	—	—	—	—	—	—	—	—	—	—	—	0000
		15:0	—	TXBUSE	RXBUSE	—	—	—	EWMARK	FWMARK	RXDONE	PKTPEND	RXACT	—	TXDONE	TXABORT	RXBUFNA	RXOVFLW	0000	

**Legend:** x = unknown value on Reset; — = unimplemented, read as '0'. Reset values are shown in hexadecimal.

- Note** 1: All registers in this table (with the exception of ETHSTAT) have corresponding CLR, SET and INV registers at their virtual addresses, plus offsets of 0x4, 0x8 and 0xC, respectively. See Section 12.1.1 "CLR, SET and INV Registers" for more information.
- 2: Reset values default to the factory programmed value.

**TABLE 4-47: ETHERNET CONTROLLER REGISTER SUMMARY FOR PIC32MX675F256H, PIC32MX675F512H, PIC32MX695F512H, PIC32MX775F256H, PIC32MX775F512H, PIC32MX795F512H, PIC32MX695F512L, PIC32MX675F256L, PIC32MX675F512L, PIC32MX775F256L, PIC32MX775F512L AND PIC32MX795F512L DEVICES<sup>(1)</sup> (CONTINUED)**

Virtual Address (BF88_#)	Register Name	Bit Range	Bits															All Resets			
			31/15	30/14	29/13	28/12	27/11	26/10	25/9	24/8	23/7	22/6	21/5	20/4	19/3	18/2	17/1		16/0		
90E0	ETHSTAT	31:16	—	—	—	—	—	—	—	—	—	—	—	—	—	—	—	—	—	—	0000
		15:0	—	—	—	—	—	—	—	—	—	BUSY	TXBUSY	RXBUSY	—	—	—	—	—	—	0000
9100	ETH RXOVFLOW	31:16	—	—	—	—	—	—	—	—	—	—	—	—	—	—	—	—	—	—	0000
		15:0	RXOVFLWCNT<15:0>															0000			
9110	ETH FRMTXOK	31:16	—	—	—	—	—	—	—	—	—	—	—	—	—	—	—	—	—	—	0000
		15:0	FRMTXOKCNT<15:0>															0000			
9120	ETH SCOLFRM	31:16	—	—	—	—	—	—	—	—	—	—	—	—	—	—	—	—	—	—	0000
		15:0	SCOLFRMCNT<15:0>															0000			
9130	ETH MCOLFRM	31:16	—	—	—	—	—	—	—	—	—	—	—	—	—	—	—	—	—	—	0000
		15:0	MCOLFRMCNT<15:0>															0000			
9140	ETH FRMRXOK	31:16	—	—	—	—	—	—	—	—	—	—	—	—	—	—	—	—	—	—	0000
		15:0	FRMRXOKCNT<15:0>															0000			
9150	ETH FCSERR	31:16	—	—	—	—	—	—	—	—	—	—	—	—	—	—	—	—	—	—	0000
		15:0	FCSERRCNT<15:0>															0000			
9160	ETH ALGNERR	31:16	—	—	—	—	—	—	—	—	—	—	—	—	—	—	—	—	—	—	0000
		15:0	ALGNERRCNT<15:0>															0000			
9200	EMACx CFG1	31:16	—	—	—	—	—	—	—	—	—	—	—	—	—	—	—	—	—	—	0000
		15:0	SOFT RESET	SIM RESET	—	—	RESET RMCS	RESET RFUN	RESET TMCS	RESET TFUN	—	—	—	—	LOOPBACK	TXPAUSE	RXPAUSE	PASSALL	RXENABLE	800D	
9210	EMACx CFG2	31:16	—	—	—	—	—	—	—	—	—	—	—	—	—	—	—	—	—	—	0000
		15:0	—	EXCESS DFR	BP NOBKOFF	NOBKOFF	—	—	LONGPRE	PUREPRE	AUTOPAD	VLANPAD	PAD ENABLE	CRC ENABLE	DELAYCRC	HUGEFRM	LENGTHCK	FULLDPLX	4082		
9220	EMACx IPGT	31:16	—	—	—	—	—	—	—	—	—	—	—	—	—	—	—	—	—	—	0000
		15:0	B2BIPKTGP<6:0>															0012			
9230	EMACx IPGR	31:16	—	—	—	—	—	—	—	—	—	—	—	—	—	—	—	—	—	—	0000
		15:0	NB2BIPKTGP1<6:0>					—	NB2BIPKTGP2<6:0>					0C12							
9240	EMACx CLRT	31:16	—	—	—	—	—	—	—	—	—	—	—	—	—	—	—	—	—	—	0000
		15:0	CWINDOW<5:0>					—	—	—	—	—	—	—	—	—	—	—	—	—	370F
9250	EMACx MAXF	31:16	—	—	—	—	—	—	—	—	—	—	—	—	—	—	—	—	—	—	0000
		15:0	MACMAXF<15:0>															05EE			

**Legend:** x = unknown value on Reset; — = unimplemented, read as '0'. Reset values are shown in hexadecimal.

- Note** 1: All registers in this table (with the exception of ETHSTAT) have corresponding CLR, SET and INV registers at their virtual addresses, plus offsets of 0x4, 0x8 and 0xC, respectively. See Section 12.1.1 "CLR, SET and INV Registers" for more information.
- 2: Reset values default to the factory programmed value.



**TABLE 4-47: ETHERNET CONTROLLER REGISTER SUMMARY FOR PIC32MX675F256H, PIC32MX675F512H, PIC32MX695F512H, PIC32MX775F256H, PIC32MX775F512H, PIC32MX795F512H, PIC32MX695F512L, PIC32MX675F256L, PIC32MX675F512L, PIC32MX775F256L, PIC32MX775F512L AND PIC32MX795F512L DEVICES<sup>(1)</sup> (CONTINUED)**

Virtual Address (BF88_#)	Register Name	Bit Range	Bits																All Resets
			31/15	30/14	29/13	28/12	27/11	26/10	25/9	24/8	23/7	22/6	21/5	20/4	19/3	18/2	17/1	16/0	
9260	EMACx SUPP	31:16	—	—	—	—	—	—	—	—	—	—	—	—	—	—	—	—	0000
		15:0	—	—	—	—	RESET RMI	—	—	SPEED RMI	—	—	—	—	—	—	—	—	1000
9270	EMACx TEST	31:16	—	—	—	—	—	—	—	—	—	—	—	—	—	—	—	—	0000
		15:0	—	—	—	—	—	—	—	—	—	—	—	—	—	TESTBP	TESTPAUSE	SHRTQNTA	0000
9280	EMACx MCFG	31:16	—	—	—	—	—	—	—	—	—	—	—	—	—	—	—	—	0000
		15:0	RESET MGMT	—	—	—	—	—	—	—	—	—	—	CLKSEL<3:0>			NOPRE	SCANINC	0020
9290	EMACx MCMD	31:16	—	—	—	—	—	—	—	—	—	—	—	—	—	—	—	—	0000
		15:0	—	—	—	—	—	—	—	—	—	—	—	—	—	—	SCAN	READ	0000
92A0	EMACx MADR	31:16	—	—	—	—	—	—	—	—	—	—	—	—	—	—	—	—	0000
		15:0	—	—	—	PHYADDR<4:0>				—	—	—	REGADDR<4:0>				—	—	0100
92B0	EMACx MWTD	31:16	—	—	—	—	—	—	—	—	—	—	—	—	—	—	—	—	0000
		15:0	MWTD<15:0>																0000
92C0	EMACx MRDD	31:16	—	—	—	—	—	—	—	—	—	—	—	—	—	—	—	—	0000
		15:0	MRDD<15:0>																0000
92D0	EMACx MIND	31:16	—	—	—	—	—	—	—	—	—	—	—	—	—	—	—	—	0000
		15:0	—	—	—	—	—	—	—	—	—	—	—	—	LINKFAIL	NOTVALID	SCAN	MIIMBUSY	0000
9300	EMACx SA0 <sup>(2)</sup>	31:16	—	—	—	—	—	—	—	—	—	—	—	—	—	—	—	—	xxxx
		15:0	STNADDR6<7:0>								STNADDR5<7:0>								xxxx
9310	EMACx SA1 <sup>(2)</sup>	31:16	—	—	—	—	—	—	—	—	—	—	—	—	—	—	—	—	xxxx
		15:0	STNADDR4<7:0>								STNADDR3<7:0>								xxxx
9320	EMACx SA2 <sup>(2)</sup>	31:16	—	—	—	—	—	—	—	—	—	—	—	—	—	—	—	—	xxxx
		15:0	STNADDR2<7:0>								STNADDR1<7:0>								xxxx

**Legend:** x = unknown value on Reset; — = unimplemented, read as '0'. Reset values are shown in hexadecimal.  
**Note 1:** All registers in this table (with the exception of ETHSTAT) have corresponding CLR, SET and INV registers at their virtual addresses, plus offsets of 0x4, 0x8 and 0xC, respectively. See Section 12.1.1 "CLR, SET and INV Registers" for more information.  
**Note 2:** Reset values default to the factory programmed value.

# PIC32MX5XX/6XX/7XX

---

NOTES:

## 5.0 FLASH PROGRAM MEMORY

**Note 1:** This data sheet summarizes the features of the PIC32MX5XX/6XX/7XX family of devices. It is not intended to be a comprehensive reference source. To complement the information in this data sheet, refer to **Section 5. “Flash Program Memory”** (DS61121) in the *“PIC32MX Family Reference Manual”*, which is available from the Microchip web site ([www.microchip.com/PIC32](http://www.microchip.com/PIC32)).

**2:** Some registers and associated bits described in this section may not be available on all devices. Refer to **Section 4.0 “Memory Organization”** in this data sheet for device-specific register and bit information.

PIC32MX5XX/6XX/7XX devices contain an internal Flash program memory for executing user code. There are three methods by which the user can program this memory:

1. Run-Time Self Programming (RTSP)
2. EJTAG Programming
3. In-Circuit Serial Programming™ (ICSP™)

RTSP is performed by software executing from either Flash or RAM memory. Information about RTSP techniques is available in **Section 5. “Flash Program Memory”** (DS61121) in the *“PIC32MX Family Reference Manual”*.

EJTAG is performed using the EJTAG port of the device and an EJTAG capable programmer.

ICSP is performed using a serial data connection to the device and allows much faster programming times than RTSP.

The EJTAG and ICSP methods are described in the *“PIC32MX Flash Programming Specification”* (DS61145), which can be downloaded from the Microchip web site.

# PIC32MX5XX/6XX/7XX

---

NOTES:

## 6.0 RESETS

**Note 1:** This data sheet summarizes the features of the PIC32MX5XX/6XX/7XX family of devices. It is not intended to be a comprehensive reference source. To complement the information in this data sheet, refer to **Section 7. “Resets”** (DS61118) in the *“PIC32MX Family Reference Manual”*, which is available from the Microchip web site ([www.microchip.com/PIC32](http://www.microchip.com/PIC32)).

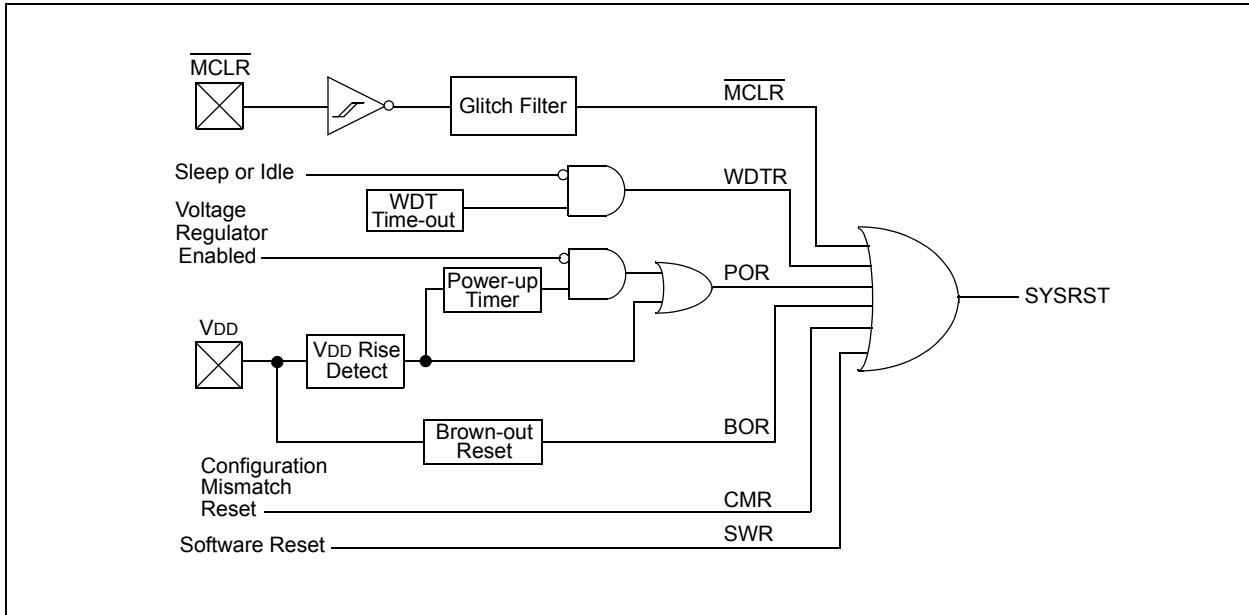
**2:** Some registers and associated bits described in this section may not be available on all devices. Refer to **Section 4.0 “Memory Organization”** in this data sheet for device-specific register and bit information.

The Reset module combines all Reset sources and controls the device Master Reset signal, SYSRST. The following is a list of device Reset sources:

- POR: Power-on Reset
- MCLR: Master Clear Reset pin
- SWR: Software Reset
- WDTR: Watchdog Timer Reset
- BOR: Brown-out Reset
- CMR: Configuration Mismatch Reset

A simplified block diagram of the Reset module is illustrated in Figure 6-1.

**FIGURE 6-1: SYSTEM RESET BLOCK DIAGRAM**



# PIC32MX5XX/6XX/7XX

---

NOTES:

## 7.0 INTERRUPT CONTROLLER

**Note 1:** This data sheet summarizes the features of the PIC32MX5XX/6XX/7XX family of devices. It is not intended to be a comprehensive reference source. To complement the information in this data sheet, refer to **Section 8. “Interrupt Controller”** (DS61108) in the *“PIC32MX Family Reference Manual”*, which is available from the Microchip web site ([www.microchip.com/PIC32](http://www.microchip.com/PIC32)).

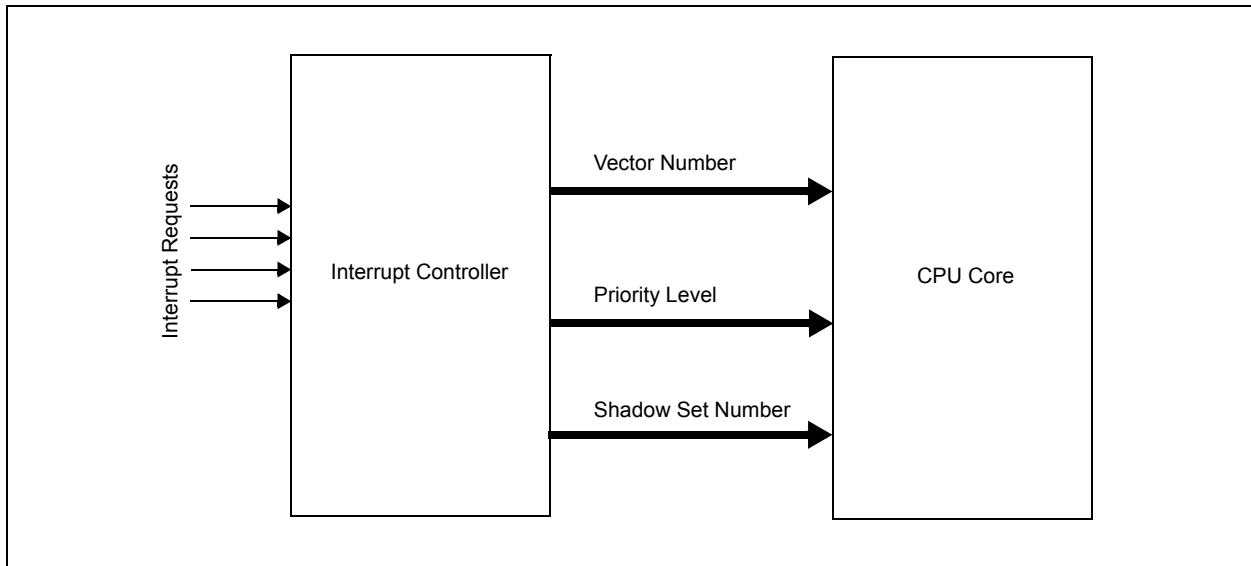
**2:** Some registers and associated bits described in this section may not be available on all devices. Refer to **Section 4.0 “Memory Organization”** in this data sheet for device-specific register and bit information.

The PIC32MX5XX/6XX/7XX interrupt module includes the following features:

- Up to 96 interrupt sources
- Up to 64 interrupt vectors
- Single and multi-vector mode operations
- Five external interrupts with edge polarity control
- Interrupt proximity timer
- Module freeze in Debug mode
- Seven user-selectable priority levels for each vector
- Four user-selectable subpriority levels within each priority
- Dedicated shadow set for user-selectable priority level
- Software can generate any interrupt
- User-configurable interrupt vector table location
- User-configurable interrupt vector spacing

PIC32MX5XX/6XX/7XX devices generate interrupt requests in response to interrupt events from peripheral modules. The interrupt control module exists externally to the CPU logic and prioritizes the interrupt events before presenting them to the CPU.

**FIGURE 7-1: INTERRUPT CONTROLLER MODULE**



# PIC32MX5XX/6XX/7XX

**TABLE 7-1: INTERRUPT IRQ, VECTOR AND BIT LOCATION**

Interrupt Source <sup>(1)</sup>	IRQ	Vector Number	Interrupt Bit Location			
			Flag	Enable	Priority	Sub-Priority
Highest Natural Order Priority						
CT – Core Timer Interrupt	0	0	IFS0<0>	IEC0<0>	IPC0<4:2>	IPC0<1:0>
CS0 – Core Software Interrupt 0	1	1	IFS0<1>	IEC0<1>	IPC0<12:10>	IPC0<9:8>
CS1 – Core Software Interrupt 1	2	2	IFS0<2>	IEC0<2>	IPC0<20:18>	IPC0<17:16>
INT0 – External Interrupt 0	3	3	IFS0<3>	IEC0<3>	IPC0<28:26>	IPC0<25:24>
T1 – Timer1	4	4	IFS0<4>	IEC0<4>	IPC1<4:2>	IPC1<1:0>
IC1 – Input Capture 1	5	5	IFS0<5>	IEC0<5>	IPC1<12:10>	IPC1<9:8>
OC1 – Output Compare 1	6	6	IFS0<6>	IEC0<6>	IPC1<20:18>	IPC1<17:16>
INT1 – External Interrupt 1	7	7	IFS0<7>	IEC0<7>	IPC1<28:26>	IPC1<25:24>
T2 – Timer2	8	8	IFS0<8>	IEC0<8>	IPC2<4:2>	IPC2<1:0>
IC2 – Input Capture 2	9	9	IFS0<9>	IEC0<9>	IPC2<12:10>	IPC2<9:8>
OC2 – Output Compare 2	10	10	IFS0<10>	IEC0<10>	IPC2<20:18>	IPC2<17:16>
INT2 – External Interrupt 2	11	11	IFS0<11>	IEC0<11>	IPC2<28:26>	IPC2<25:24>
T3 – Timer3	12	12	IFS0<12>	IEC0<12>	IPC3<4:2>	IPC3<1:0>
IC3 – Input Capture 3	13	13	IFS0<13>	IEC0<13>	IPC3<12:10>	IPC3<9:8>
OC3 – Output Compare 3	14	14	IFS0<14>	IEC0<14>	IPC3<20:18>	IPC3<17:16>
INT3 – External Interrupt 3	15	15	IFS0<15>	IEC0<15>	IPC3<28:26>	IPC3<25:24>
T4 – Timer4	16	16	IFS0<16>	IEC0<16>	IPC4<4:2>	IPC4<1:0>
IC4 – Input Capture 4	17	17	IFS0<17>	IEC0<17>	IPC4<12:10>	IPC4<9:8>
OC4 – Output Compare 4	18	18	IFS0<18>	IEC0<18>	IPC4<20:18>	IPC4<17:16>
INT4 – External Interrupt 4	19	19	IFS0<19>	IEC0<19>	IPC4<28:26>	IPC4<25:24>
T5 – Timer5	20	20	IFS0<20>	IEC0<20>	IPC5<4:2>	IPC5<1:0>
IC5 – Input Capture 5	21	21	IFS0<21>	IEC0<21>	IPC5<12:10>	IPC5<9:8>
OC5 – Output Compare 5	22	22	IFS0<22>	IEC0<22>	IPC5<20:18>	IPC5<17:16>
SPI1E – SPI1 Fault	23	23	IFS0<23>	IEC0<23>	IPC5<28:26>	IPC5<25:24>
SPI1RX – SPI1 Receive Done	24	23	IFS0<24>	IEC0<24>	IPC5<28:26>	IPC5<25:24>
SPI1TX – SPI1 Transfer Done	25	23	IFS0<25>	IEC0<25>	IPC5<28:26>	IPC5<25:24>
U1AE – UART1A Error	26	24	IFS0<26>	IEC0<26>	IPC6<4:2>	IPC6<1:0>
SPI1AE – SPI1A Fault						
I2C1AB – I2C1A Bus Collision Event						
U1ARX – UART1A Receiver	27	24	IFS0<27>	IEC0<27>	IPC6<4:2>	IPC6<1:0>
SPI1ARX – SPI1A Receive Done						
I2C1AS – I2C1A Slave Event						
U1ATX – UART1A Transmitter	28	24	IFS0<28>	IEC0<28>	IPC6<4:2>	IPC6<1:0>
SPI1ATX – SPI1A Transfer Done						
I2C1AM – I2C1A Master Event						
I2C1B – I2C1 Bus Collision Event	29	25	IFS0<29>	IEC0<29>	IPC6<12:10>	IPC6<9:8>
I2C1S – I2C1 Slave Event	30	25	IFS0<30>	IEC0<30>	IPC6<12:10>	IPC6<9:8>
I2C1M – I2C1 Master Event	31	25	IFS0<31>	IEC0<31>	IPC6<12:10>	IPC6<9:8>
CN – Input Change Interrupt	32	26	IFS1<0>	IEC1<0>	IPC6<20:18>	IPC6<17:16>
AD1 – ADC1 Convert Done	33	27	IFS1<1>	IEC1<1>	IPC6<28:26>	IPC6<25:24>

**Note 1:** Not all interrupt sources are available on all devices. See Table 1, Table 2 and Table 3 for the list of available peripherals.



# PIC32MX5XX/6XX/7XX

**TABLE 7-1: INTERRUPT IRQ, VECTOR AND BIT LOCATION (CONTINUED)**

Interrupt Source <sup>(1)</sup>	IRQ	Vector Number	Interrupt Bit Location			
			Flag	Enable	Priority	Sub-Priority
PMP – Parallel Master Port	34	28	IFS1<2>	IEC1<2>	IPC7<4:2>	IPC7<1:0>
CMP1 – Comparator Interrupt	35	29	IFS1<3>	IEC1<3>	IPC7<12:10>	IPC7<9:8>
CMP2 – Comparator Interrupt	36	30	IFS1<4>	IEC1<4>	IPC7<20:18>	IPC7<17:16>
U2AE – UART2A Error SPI2AE – SPI2A Fault I2C2AB – I2C2A Bus Collision Event	37	31	IFS1<5>	IEC1<5>	IPC7<28:26>	IPC7<25:24>
U2ARX – UART2A Receiver SPI2ARX – SPI2A Receive Done I2C2AS – I2C2A Slave Event	38	31	IFS1<6>	IEC1<6>	IPC7<28:26>	IPC7<25:24>
U2ATX – UART2A Transmitter SPI2ATX – SPI2A Transfer Done IC2AM – I2C2A Master Event	39	31	IFS1<7>	IEC1<7>	IPC7<28:26>	IPC7<25:24>
U3AE – UART3A Error SPI3AE – SPI3A Fault I2C3AB – I2C3A Bus Collision Event	40	32	IFS1<8>	IEC1<8>	IPC8<4:2>	IPC8<1:0>
U3ARX – UART3A Receiver SPI3ARX – SPI3A Receive Done I2C3AS – I2C3A Slave Event	41	32	IFS1<9>	IEC1<9>	IPC8<4:2>	IPC8<1:0>
U3ATX – UART3A Transmitter SPI3ATX – SPI3A Transfer Done IC3AM – I2C3A Master Event	42	32	IFS1<10>	IEC1<10>	IPC8<4:2>	IPC8<1:0>
I2C2B – I2C2 Bus Collision Event	43	33	IFS1<11>	IEC1<11>	IPC8<12:10>	IPC8<9:8>
I2C2S – I2C2 Slave Event	44	33	IFS1<12>	IEC1<12>	IPC8<12:10>	IPC8<9:8>
I2C2M – I2C2 Master Event	45	33	IFS1<13>	IEC1<13>	IPC8<12:10>	IPC8<9:8>
FSCM – Fail-Safe Clock Monitor	46	34	IFS1<14>	IEC1<14>	IPC8<20:18>	IPC8<17:16>
RTCC – Real-Time Clock and Calendar	47	35	IFS1<15>	IEC1<15>	IPC8<28:26>	IPC8<25:24>
DMA0 – DMA Channel 0	48	36	IFS1<16>	IEC1<16>	IPC9<4:2>	IPC9<1:0>
DMA1 – DMA Channel 1	49	37	IFS1<17>	IEC1<17>	IPC9<12:10>	IPC9<9:8>
DMA2 – DMA Channel 2	50	38	IFS1<18>	IEC1<18>	IPC9<20:18>	IPC9<17:16>
DMA3 – DMA Channel 3	51	39	IFS1<19>	IEC1<19>	IPC9<28:26>	IPC9<25:24>
DMA4 – DMA Channel 4	52	40	IFS1<20>	IEC1<20>	IPC10<4:2>	IPC10<1:0>
DMA5 – DMA Channel 5	53	41	IFS1<21>	IEC1<21>	IPC10<12:10>	IPC10<9:8>
DMA6 – DMA Channel 6	54	42	IFS1<22>	IEC1<22>	IPC10<20:18>	IPC10<17:16>
DMA7 – DMA Channel 7	55	43	IFS1<23>	IEC1<23>	IPC10<28:26>	IPC10<25:24>
FCE – Flash Control Event	56	44	IFS1<24>	IEC1<24>	IPC11<4:2>	IPC11<1:0>
USB – USB Interrupt	57	45	IFS1<25>	IEC1<25>	IPC11<12:10>	IPC11<9:8>
CAN1 – Control Area Network 1	58	46	IFS1<26>	IEC1<26>	IPC11<20:18>	IPC11<17:16>
CAN2 – Control Area Network 2	59	47	IFS1<27>	IEC1<27>	IPC11<28:26>	IPC11<25:24>
ETH – Ethernet Interrupt	60	48	IFS1<28>	IEC1<28>	IPC12<4:2>	IPC12<1:0>
IC1E – Input Capture 1 Error	61	5	IFS1<29>	IEC1<29>	IPC1<12:10>	IPC1<9:8>
IC2E – Input Capture 2 Error	62	9	IFS1<30>	IEC1<30>	IPC2<12:10>	IPC2<9:8>
IC3E – Input Capture 3 Error	63	13	IFS1<31>	IEC1<31>	IPC3<12:10>	IPC3<9:8>
IC4E – Input Capture 4 Error	64	17	IFS2<0>	IEC2<0>	IPC4<12:10>	IPC4<9:8>

**Note 1:** Not all interrupt sources are available on all devices. See Table 1, Table 2 and Table 3 for the list of available peripherals.

# PIC32MX5XX/6XX/7XX

**TABLE 7-1: INTERRUPT IRQ, VECTOR AND BIT LOCATION (CONTINUED)**

Interrupt Source <sup>(1)</sup>	IRQ	Vector Number	Interrupt Bit Location			
			Flag	Enable	Priority	Sub-Priority
IC4E – Input Capture 5 Error	65	21	IFS2<1>	IEC2<1>	IPC5<12:10>	IPC5<9:8>
PMPE – Parallel Master Port Error	66	28	IFS2<2>	IEC2<2>	IPC7<4:2>	IPC7<1:0>
U1BE – UART1B Error	67	49	IFS2<3>	IEC2<3>	IPC12<12:10>	IPC12<9:8>
U1BRX – UART1B Receiver	68	49	IFS2<4>	IEC2<4>	IPC12<12:10>	IPC12<9:8>
U1BTX – UART1B Transmitter	69	49	IFS2<5>	IEC2<5>	IPC12<12:10>	IPC12<9:8>
U2BE – UART2B Error	70	50	IFS2<6>	IEC2<6>	IPC12<20:18>	IPC12<17:16>
U2BRX – UART2B Receiver	71	50	IFS2<7>	IEC2<7>	IPC12<20:18>	IPC12<17:16>
U2BTX – UART2B Transmitter	72	50	IFS2<8>	IEC2<8>	IPC12<20:18>	IPC12<17:16>
U3BE – UART3B Error	73	51	IFS2<9>	IEC2<9>	IPC12<28:26>	IPC12<25:24>
U3BRX – UART3B Receiver	74	51	IFS2<10>	IEC2<10>	IPC12<28:26>	IPC12<25:24>
U3BTX – UART3B Transmitter	75	51	IFS2<11>	IEC2<11>	IPC12<28:26>	IPC12<25:24>
(Reserved)	—	—	—	—	—	—
Lowest Natural Order Priority						

**Note 1:** Not all interrupt sources are available on all devices. See Table 1, Table 2 and Table 3 for the list of available peripherals.

## 8.0 OSCILLATOR CONFIGURATION

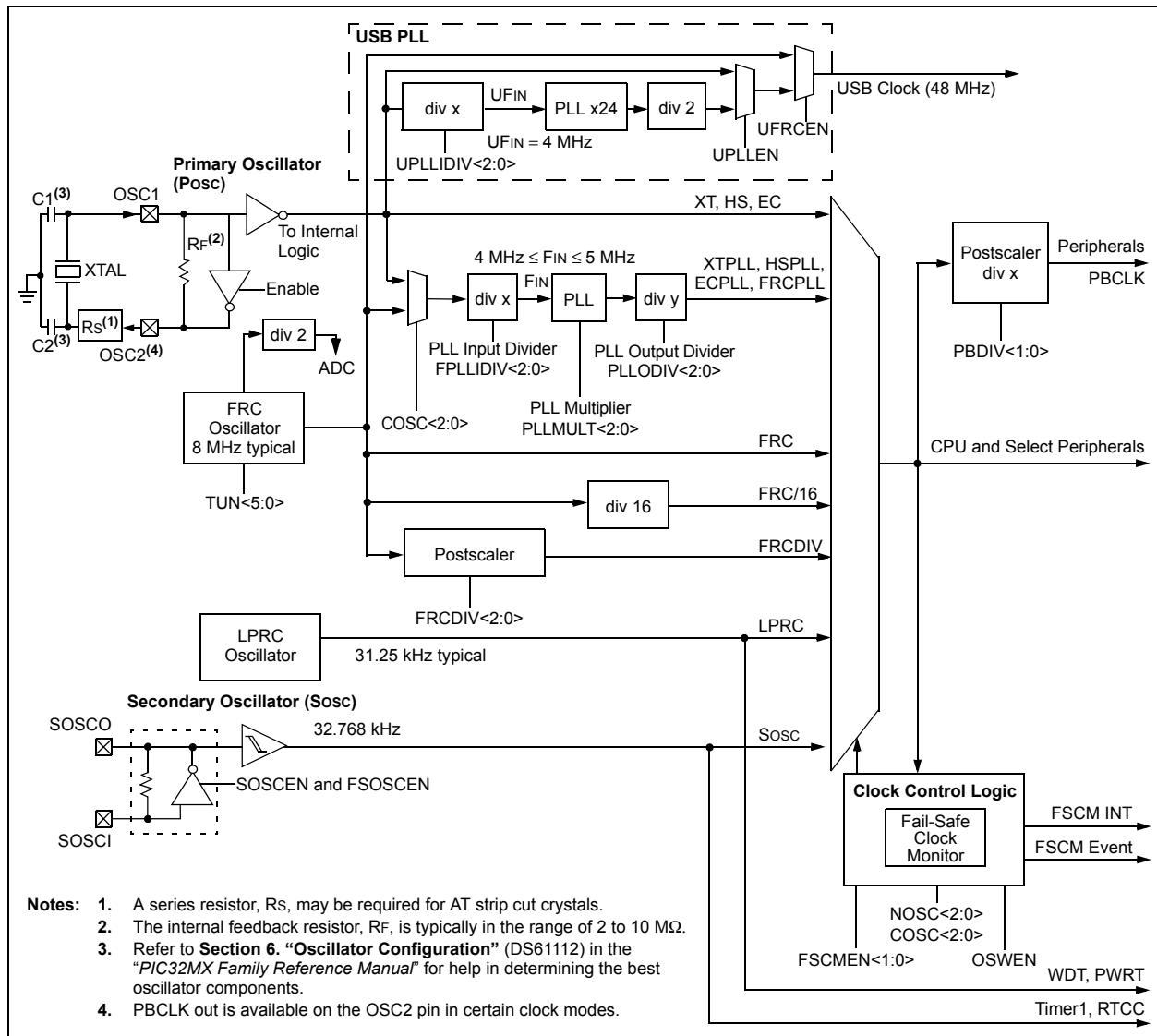
**Note 1:** This data sheet summarizes the features of the PIC32MX5XX/6XX/7XX family of devices. It is not intended to be a comprehensive reference source. To complement the information in this data sheet, refer to **Section 6. "Oscillator Configuration"** (DS61112) in the "PIC32MX Family Reference Manual", which is available from the Microchip web site ([www.microchip.com/PIC32](http://www.microchip.com/PIC32)).

**2:** Some registers and associated bits described in this section may not be available on all devices. Refer to **Section 4.0 "Memory Organization"** in this data sheet for device-specific register and bit information.

The PIC32MX5XX/6XX/7XX oscillator system has the following modules and features:

- A Total of four external and internal oscillator options as clock sources
- On-Chip PLL with user-selectable input divider, multiplier and output divider to boost operating frequency on select internal and external oscillator sources
- On-Chip user-selectable divisor postscaler on select oscillator sources
- Software-controllable switching between various clock sources
- A Fail-Safe Clock Monitor (FSCM) that detects clock failure and permits safe application recovery or shutdown
- Dedicated On-Chip PLL for USB peripheral

**FIGURE 8-1: PIC32MX5XX/6XX/7XX FAMILY CLOCK DIAGRAM**



# PIC32MX5XX/6XX/7XX

---

NOTES:

## 9.0 PREFETCH CACHE

**Note 1:** This data sheet summarizes the features of the PIC32MX5XX/6XX/7XX family of devices. It is not intended to be a comprehensive reference source. To complement the information in this data sheet, refer to **Section 4. “Prefetch Cache”** (DS61119) in the *“PIC32MX Family Reference Manual”*, which is available from the Microchip web site ([www.microchip.com/PIC32](http://www.microchip.com/PIC32)).

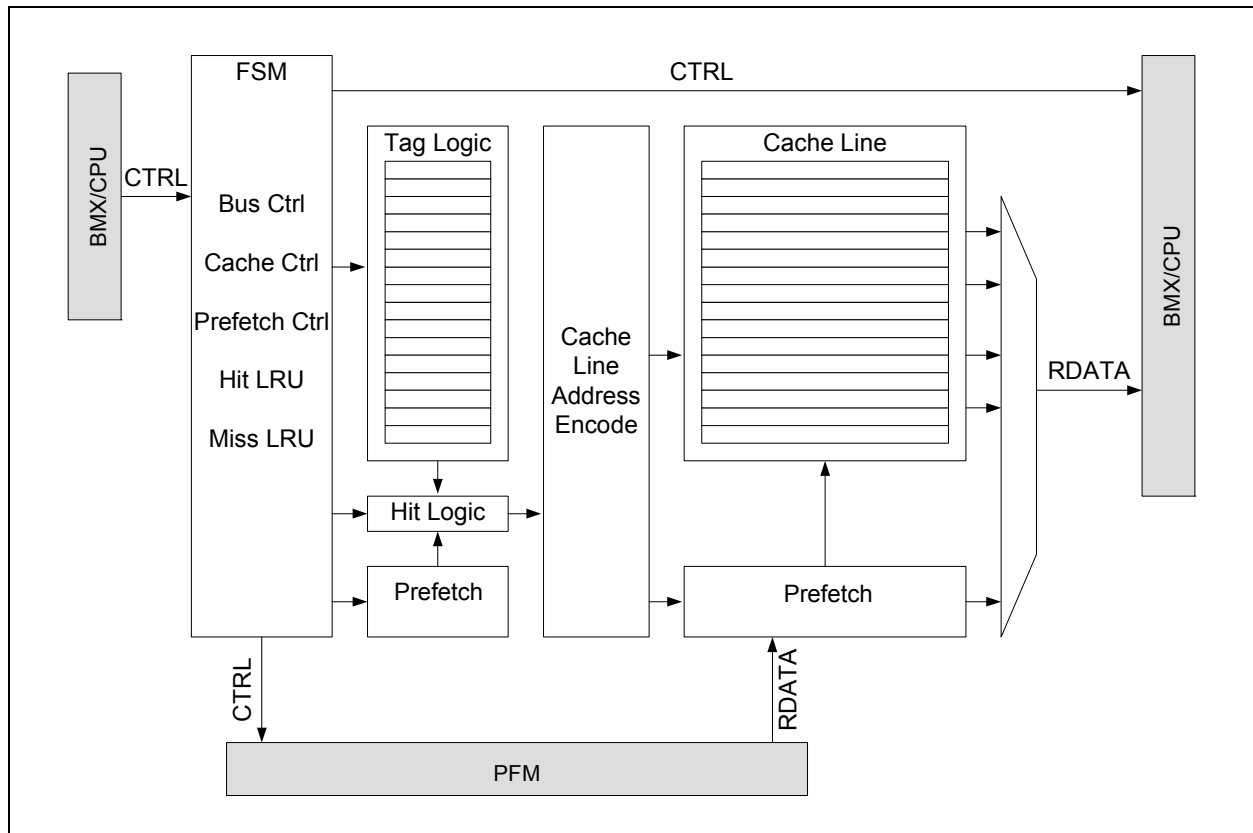
**2:** Some registers and associated bits described in this section may not be available on all devices. Refer to **Section 4.0 “Memory Organization”** in this data sheet for device-specific register and bit information.

Prefetch cache increases performance for applications executing out of the cacheable program Flash memory regions by implementing instruction caching, constant data caching and instruction prefetching.

### 9.1 Features

- 16 fully associative lockable cache lines
- 16-byte cache lines
- Up to four cache lines allocated to data
- Two cache lines with address mask to hold repeated instructions
- Pseudo LRU replacement policy
- All cache lines are software writable
- 16-byte parallel memory fetch
- Predictive instruction prefetch

**FIGURE 9-1: PREFETCH MODULE BLOCK DIAGRAM**



# PIC32MX5XX/6XX/7XX

---

NOTES:

## 10.0 DIRECT MEMORY ACCESS (DMA) CONTROLLER

**Note 1:** This data sheet summarizes the features of the PIC32MX5XX/6XX/7XX family of devices. It is not intended to be a comprehensive reference source. To complement the information in this data sheet, refer to **Section 31. “Direct Memory Access (DMA) Controller”** (DS61117) in the *“PIC32MX Family Reference Manual”*, which is available from the Microchip web site ([www.microchip.com/PIC32](http://www.microchip.com/PIC32)).

**2:** Some registers and associated bits described in this section may not be available on all devices. Refer to **Section 4.0 “Memory Organization”** in this data sheet for device-specific register and bit information.

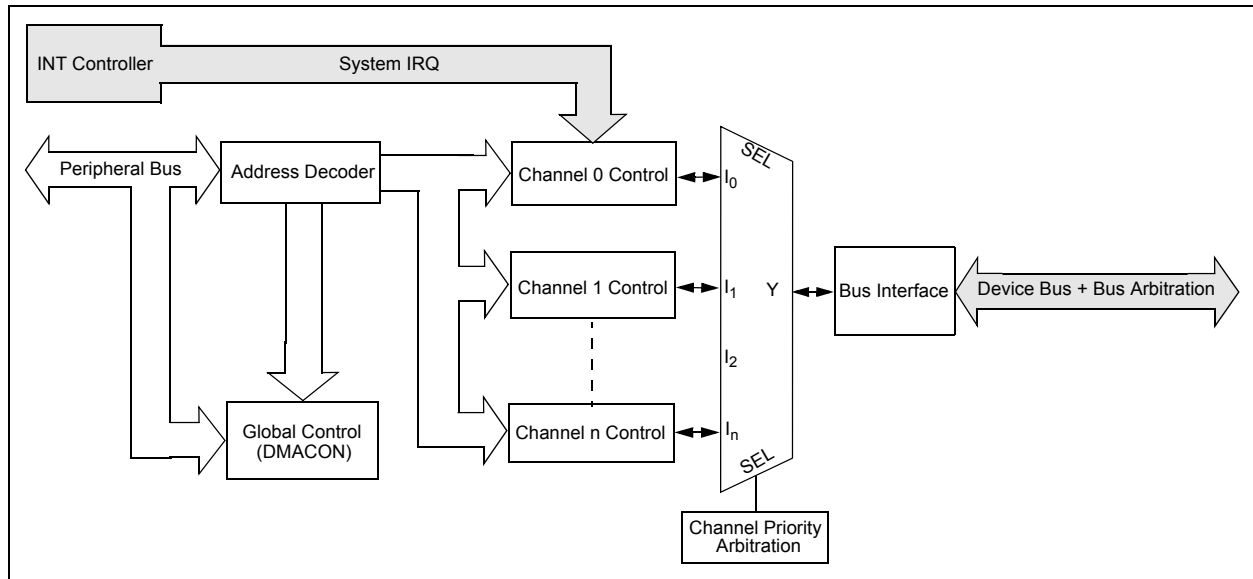
The PIC32MX Direct Memory Access (DMA) controller is a bus master module useful for data transfers between different devices without CPU intervention. The source and destination of a DMA transfer can be any of the memory mapped modules existent in the PIC32MX (such as Peripheral Bus (PBUS) devices: SPI, UART, PMP, etc.) or memory itself.

Following are some of the key features of the DMA controller module:

- Four identical channels, each featuring:
  - Auto-increment source and destination address registers
  - Source and destination pointers
  - Memory to memory and memory to peripheral transfers

- Automatic word-size detection:
  - Transfer granularity, down to byte level
  - Bytes need not be word-aligned at source and destination
- Fixed priority channel arbitration
- Flexible DMA channel operating modes:
  - Manual (software) or automatic (interrupt) DMA requests
  - One-Shot or Auto-Repeat Block Transfer modes
  - Channel-to-channel chaining
- Flexible DMA requests:
  - A DMA request can be selected from any of the peripheral interrupt sources
  - Each channel can select any (appropriate) observable interrupt as its DMA request source
  - A DMA transfer abort can be selected from any of the peripheral interrupt sources
  - Pattern (data) match transfer termination
- Multiple DMA channel status interrupts:
  - DMA channel block transfer complete
  - Source empty or half empty
  - Destination full or half full
  - DMA transfer aborted due to an external event
  - Invalid DMA address generated
- DMA debug support features:
  - Most recent address accessed by a DMA channel
  - Most recent DMA channel to transfer data
- CRC Generation module:
  - CRC module can be assigned to any of the available channels
  - CRC module is highly configurable

**FIGURE 10-1: DMA BLOCK DIAGRAM**



# PIC32MX5XX/6XX/7XX

---

NOTES:



## 11.0 USB ON-THE-GO (OTG)

**Note 1:** This data sheet summarizes the features of the PIC32MX5XX/6XX/7XX family of devices. It is not intended to be a comprehensive reference source. To complement the information in this data sheet, refer to **Section 27. “USB On-The-Go (OTG)”** (DS61126) in the *“PIC32MX Family Reference Manual”*, which is available from the Microchip web site ([www.microchip.com/PIC32](http://www.microchip.com/PIC32)).

**2:** Some registers and associated bits described in this section may not be available on all devices. Refer to **Section 4.0 “Memory Organization”** in this data sheet for device-specific register and bit information.

The Universal Serial Bus (USB) module contains analog and digital components to provide a USB 2.0 full-speed and low-speed embedded host, full-speed device or OTG implementation with a minimum of external components. This module in Host mode is intended for use as an embedded host and therefore does not implement a UHCI or OHCI controller.

The USB module consists of the clock generator, the USB voltage comparators, the transceiver, the Serial Interface Engine (SIE), a dedicated USB DMA controller, pull-up and pull-down resistors, and the register interface. A block diagram of the PIC32MX USB OTG module is presented in Figure 11-1.

The clock generator provides the 48 MHz clock required for USB full-speed and low-speed communication. The voltage comparators monitor the voltage on the VBUS pin to determine the state of the bus. The transceiver provides the analog translation between the USB bus and the digital logic. The SIE is a state machine that transfers data to and from the endpoint buffers and generates the hardware protocol for data transfers. The USB DMA controller transfers data between the data buffers in RAM and the SIE. The integrated pull-up and pull-down resistors eliminate the need for external signaling components. The register interface allows the CPU to configure and communicate with the module.

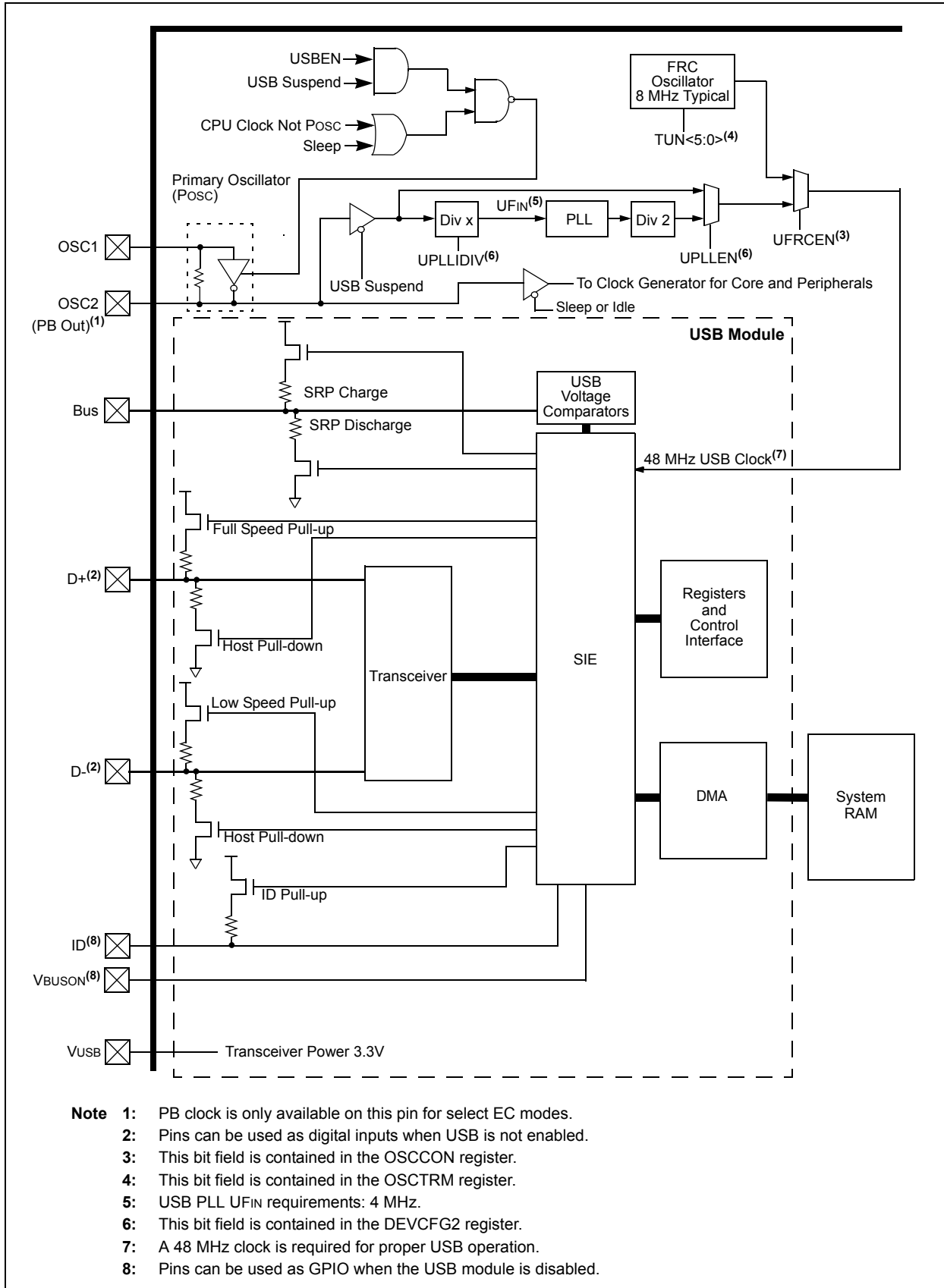
The PIC32MX USB module includes the following features:

- USB Full-speed support for host and device
- Low-speed host support
- USB OTG support
- Integrated signaling resistors
- Integrated analog comparators for VBUS monitoring
- Integrated USB transceiver
- Transaction handshaking performed by hardware
- Endpoint buffering anywhere in system RAM
- Integrated DMA to access system RAM and Flash

**Note:** The implementation and use of the USB specifications, as well as other third party specifications or technologies, may require licensing; including, but not limited to, USB Implementers Forum, Inc. (also referred to as USB-IF). The user is fully responsible for investigating and satisfying any applicable licensing obligations.

# PIC32MX5XX/6XX/7XX

**FIGURE 11-1: PIC32MX5XX/6XX/7XX FAMILY USB INTERFACE DIAGRAM**



## 12.0 I/O PORTS

**Note 1:** This data sheet summarizes the features of the PIC32MX5XX/6XX/7XX family of devices. It is not intended to be a comprehensive reference source. To complement the information in this data sheet, refer to **Section 12. "I/O Ports"** (DS61120) in the *"PIC32MX Family Reference Manual"*, which is available from the Microchip web site ([www.microchip.com/PIC32](http://www.microchip.com/PIC32)).

**2:** Some registers and associated bits described in this section may not be available on all devices. Refer to **Section 4.0 "Memory Organization"** in this data sheet for device-specific register and bit information.

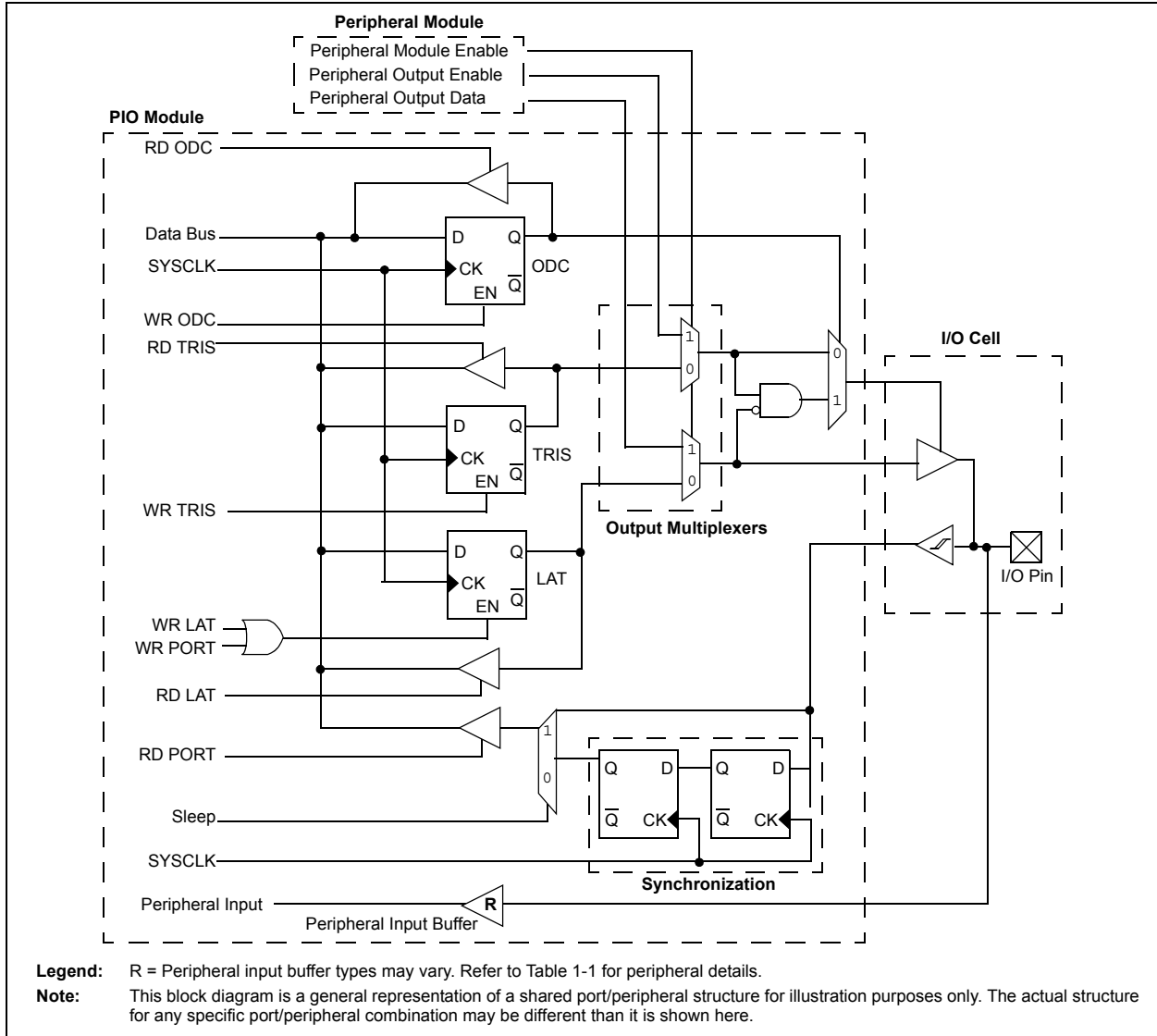
General purpose I/O pins are the simplest of peripherals. They allow the PIC<sup>®</sup> MCU to monitor and control other devices. To add flexibility and functionality, some pins are multiplexed with alternate function(s). These functions depend on which peripheral features are on the device. In general, when a peripheral is functioning, that pin may not be used as a general purpose I/O pin.

Following are some of the key features of this module:

- Individual output pin open-drain enable/disable
- Individual input pin weak pull-up enable/disable
- Monitor selective inputs and generate interrupt when change in pin state is detected
- Operation during CPU Sleep and Idle modes
- Fast bit manipulation using CLR, SET and INV registers

Figure 12-1 illustrates a block diagram of a typical multiplexed I/O port.

**FIGURE 12-1: BLOCK DIAGRAM OF A TYPICAL MULTIPLEXED PORT STRUCTURE**



# PIC32MX5XX/6XX/7XX

## 12.1 Parallel I/O (PIO) Ports

All port pins have three registers (TRIS, LAT and PORT) that are directly associated with their operation.

TRIS is a Data Direction or Tri-State Control register that determines whether a digital pin is an input or an output. Setting a TRISx register bit = 1 configures the corresponding I/O pin as an input; setting a TRISx register bit = 0 configures the corresponding I/O pin as an output. All port I/O pins are defined as inputs after a device Reset. Certain I/O pins are shared with analog peripherals and default to analog inputs after a device Reset.

PORT is a register used to read the current state of the signal applied to the port I/O pins. Writing to a PORTx register performs a write to the port's latch, LATx register, latching the data to the port's I/O pins.

LAT is a register used to write data to the port I/O pins. The LATx Latch register holds the data written to either the LATx or PORTx registers. Reading the LATx Latch register reads the last value written to the corresponding PORT or Latch register.

Not all port I/O pins are implemented on some devices, therefore, the corresponding PORTx, LATx and TRISx register bits will read as zeros.

### 12.1.1 CLR, SET AND INV REGISTERS

Every I/O module register has a corresponding CLR (clear), SET (set) and INV (invert) register designed to provide fast atomic bit manipulations. As the name of the register implies, a value written to a SET, CLR or INV register effectively performs the implied operation, but only on the corresponding base register and only bits specified as '1' are modified. Bits specified as '0' are not modified.

Reading SET, CLR and INV registers returns undefined values. To see the affects of a write operation to a SET, CLR or INV register, the base register must be read.

**Note:** Using a PORTxINV register to toggle a bit is recommended because the operation is performed in hardware atomically, using fewer instructions, as compared to the traditional read-modify-write method shown below:  

```
PORTC ^= 0x0001;
```

### 12.1.2 DIGITAL INPUTS

Pins are configured as digital inputs by setting the corresponding TRIS register bits = 1. When configured as inputs, they are either TTL buffers or Schmitt Triggers. Several digital pins share functionality with analog inputs and default to the analog inputs at POR. Setting the corresponding bit in the AD1PCFG register = 1 enables the pin as a digital pin.

The maximum input voltage allowed on the input pins is the same as the maximum  $V_{IH}$  specification. Refer to **Section 31.0 "Electrical Characteristics"** for  $V_{IH}$  specification details.

**Note:** Analog levels on any pin that is defined as a digital input (including the ANx pins) may cause the input buffer to consume current that exceeds the device specifications.

### 12.1.3 ANALOG INPUTS

Certain pins can be configured as analog inputs used by the ADC and comparator modules. Setting the corresponding bits in the AD1PCFG register = 0 enables the pin as an analog input pin and must have the corresponding TRIS bit set = 1 (input). If the TRIS bit is cleared = 0 (output), the digital output level ( $V_{OH}$  or  $V_{OL}$ ) will be converted. Any time a port I/O pin is configured as analog, its digital input is disabled and the corresponding PORTx register bit will read '0'. The AD1PCFG register has a default value of 0x0000; therefore, all pins that share ANx functions are analog (not digital) by default.

### 12.1.4 DIGITAL OUTPUTS

Pins are configured as digital outputs by setting the corresponding TRIS register bits = 0. When configured as digital outputs, these pins are CMOS drivers or can be configured as open-drain outputs by setting the corresponding bits in the ODCx Open-Drain Configuration register.

The open-drain feature allows generation of outputs higher than  $V_{DD}$  (e.g., 5V) on any desired 5V tolerant pins by using external pull-up resistors. The maximum open-drain voltage allowed is the same as the maximum  $V_{IH}$  specification.

See the **"Pin Diagrams"** section for the available pins and their functionality.

### 12.1.5 ANALOG OUTPUTS

Certain pins can be configured as analog outputs, such as the  $CV_{REF}$  output voltage used by the comparator module. Configuring the comparator reference module to provide this output will present the analog output voltage on the pin, independent of the TRIS register setting for the corresponding pin.

### 12.1.6 INPUT CHANGE NOTIFICATION

The input change notification function of the I/O ports (CNx) allows devices to generate interrupt requests in response to change of state on selected pin.

Each CNx pin also has a weak pull-up, which acts as a current source connected to the pin. The pull-ups are enabled by setting corresponding bit in CNPUE register.



# PIC32MX5XX/6XX/7XX

---

NOTES:

## 14.0 TIMER2/3, TIMER4/5

**Note 1:** This data sheet summarizes the features of the PIC32MX5XX/6XX/7XX family of devices. It is not intended to be a comprehensive reference source. To complement the information in this data sheet, refer to **Section 14. “Timers”** (DS61105) of the *“PIC32MX Family Reference Manual”*, which is available from the Microchip web site ([www.microchip.com/PIC32](http://www.microchip.com/PIC32)).

**2:** Some registers and associated bits described in this section may not be available on all devices. Refer to **Section 4.0 “Memory Organization”** in this data sheet for device-specific register and bit information.

This family of PIC32MX devices features four synchronous 16-bit timers (default) that can operate as a free-running interval timer for various timing applications and counting external events. The following modes are supported:

- Synchronous internal 16-bit timer
- Synchronous internal 16-bit gated timer
- Synchronous external 16-bit timer

Two 32-bit synchronous timers are available by combining Timer2 with Timer3 and Timer4 with Timer5. The 32-bit timers can operate in three modes:

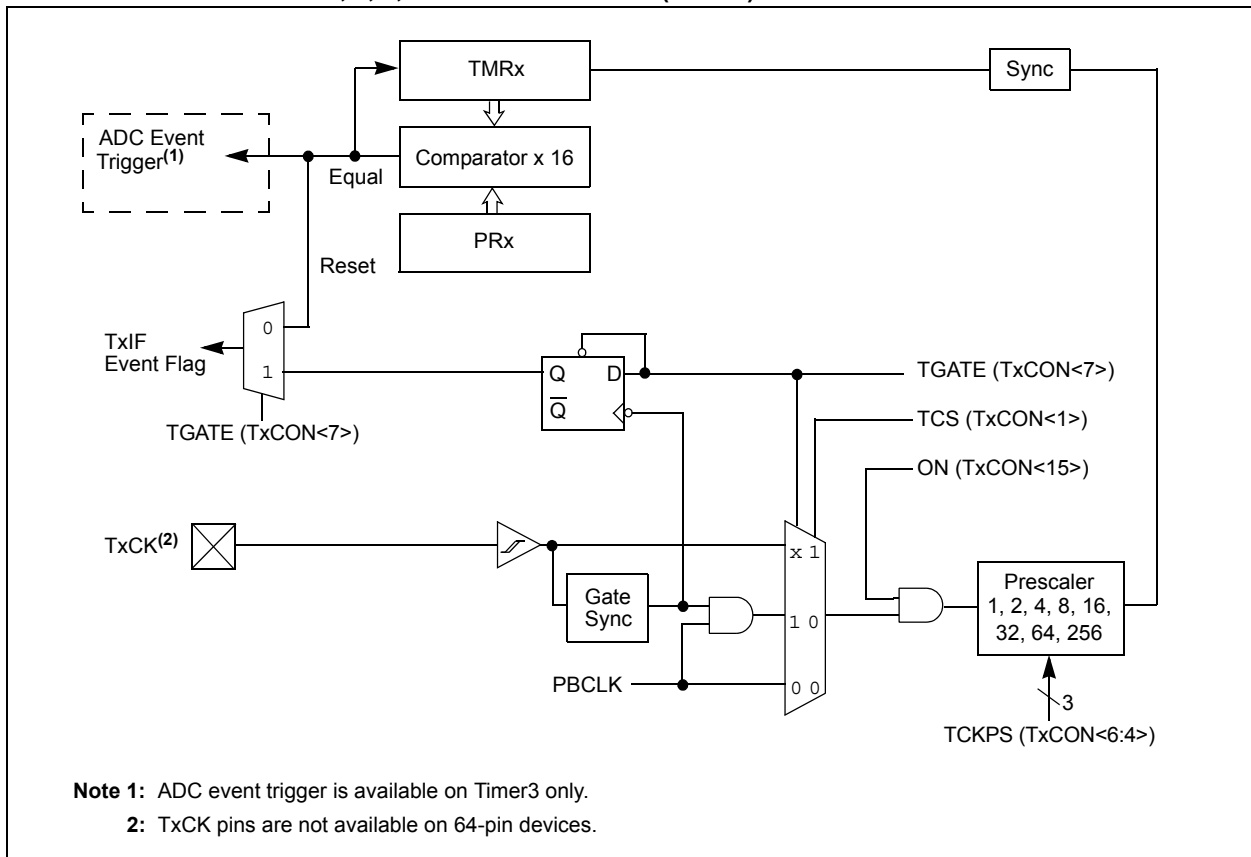
- Synchronous internal 32-bit timer
- Synchronous internal 32-bit gated timer
- Synchronous external 32-bit timer

**Note:** In this chapter, references to registers, TxCON, TMRx and PRx, use ‘x’ to represent Timer2 through 5 in 16-bit modes. In 32-bit modes, ‘x’ represents Timer2 or 4; ‘y’ represents Timer3 or 5.

### 14.1 Additional Supported Features

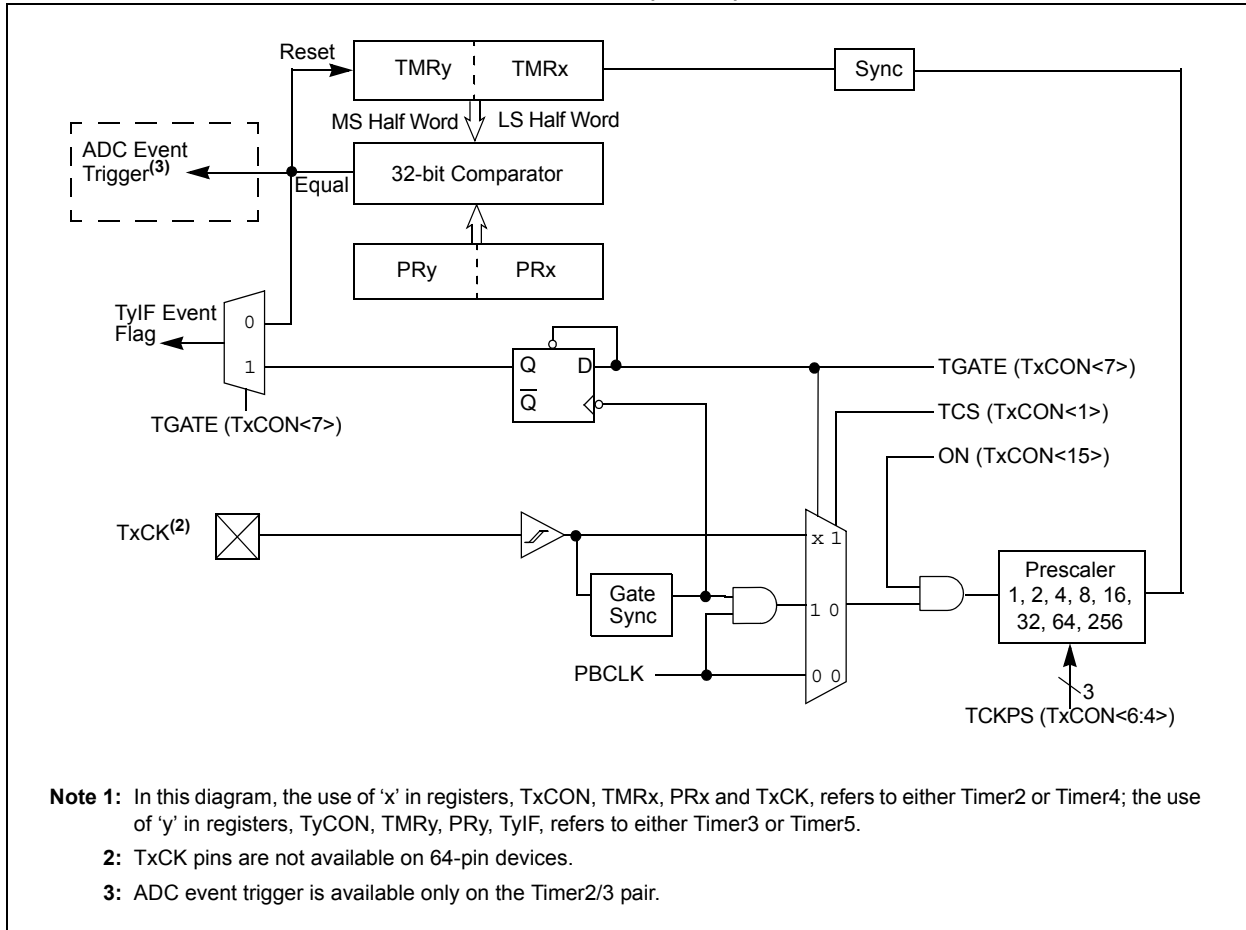
- Selectable clock prescaler
- Timers operational during CPU idle
- Time base for Input Capture and Output Compare modules (Timer2 and Timer3 only)
- ADC event trigger (Timer3 only)
- Fast bit manipulation using CLR, SET and INV registers

**FIGURE 14-1: TIMER2, 3, 4, 5 BLOCK DIAGRAM (16-BIT)**



# PIC32MX5XX/6XX/7XX

**FIGURE 14-2: TIMER2/3, 4/5 BLOCK DIAGRAM (32-BIT)<sup>(1)</sup>**





## 15.0 INPUT CAPTURE

**Note 1:** This data sheet summarizes the features of the PIC32MX5XX/6XX/7XX family of devices. It is not intended to be a comprehensive reference source. To complement the information in this data sheet, refer to **Section 15. "Input Capture"** (DS61122) of the "PIC32MX Family Reference Manual", which is available from the Microchip web site ([www.microchip.com/PIC32](http://www.microchip.com/PIC32)).

**2:** Some registers and associated bits described in this section may not be available on all devices. Refer to **Section 4.0 "Memory Organization"** in this data sheet for device-specific register and bit information.

The Input Capture module is useful in applications requiring frequency (period) and pulse measurement.

The Input Capture module captures the 16-bit or 32-bit value of the selected Time Base registers when an event occurs at the ICx pin. The following events cause capture events:

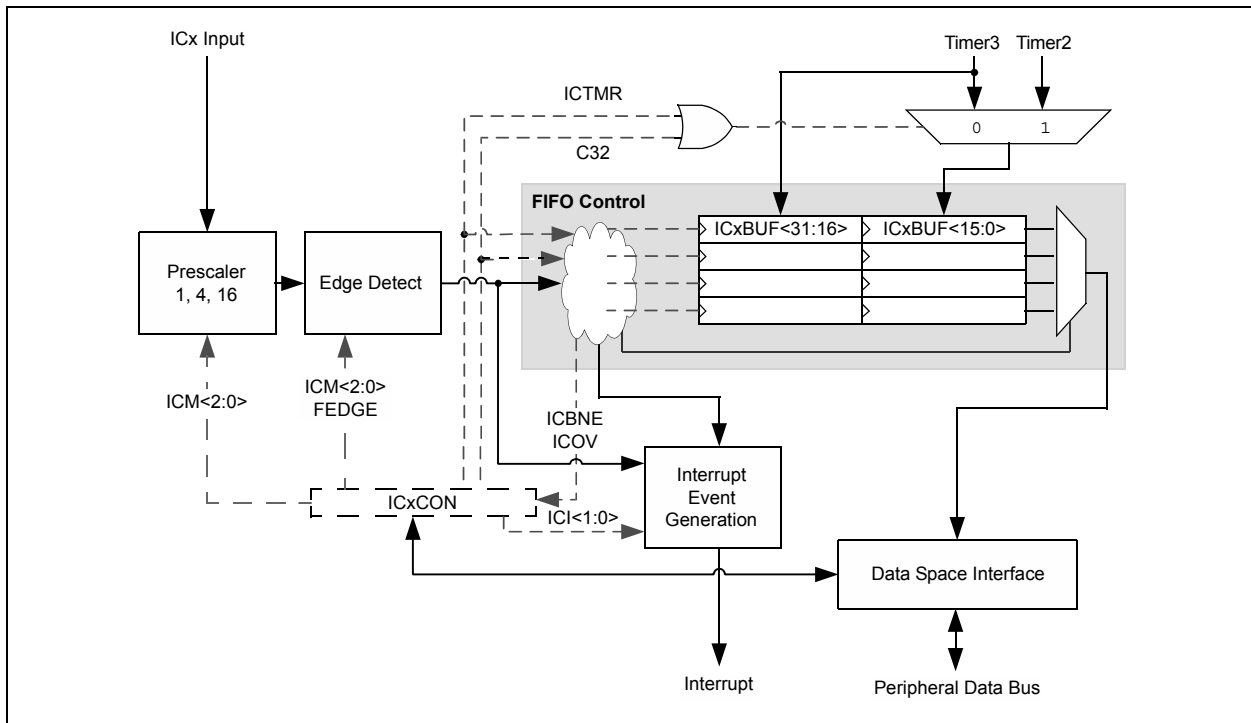
1. Simple capture event modes
  - Capture timer value on every falling edge of input at ICx pin
  - Capture timer value on every rising edge of input at ICx pin
2. Capture timer value on every edge (rising and falling)
3. Capture timer value on every edge (rising and falling), specified edge first.
4. Prescaler capture event modes
  - Capture timer value on every 4th rising edge of input at ICx pin
  - Capture timer value on every 16th rising edge of input at ICx pin

Each input capture channel can select between one of two 16-bit timers (Timer2 or Timer3) for the time base, or two 16-bit timers (Timer2 and Timer3) together to form a 32-bit timer. The selected timer can use either an internal or external clock.

Other operational features include:

- Device wake-up from capture pin during CPU Sleep and Idle modes
- Interrupt on input capture event
- 4-word FIFO buffer for capture values  
Interrupt optionally generated after 1, 2, 3 or 4 buffer locations are filled
- Input capture can also be used to provide additional sources of external interrupts

**FIGURE 15-1: INPUT CAPTURE BLOCK DIAGRAM**



# PIC32MX5XX/6XX/7XX

---

NOTES:

## 16.0 OUTPUT COMPARE

**Note 1:** This data sheet summarizes the features of the PIC32MX5XX/6XX/7XX family of devices. It is not intended to be a comprehensive reference source. To complement the information in this data sheet, refer to **Section 16. “Output Capture”** (DS61111) in the *“PIC32MX Family Reference Manual”*, which is available from the Microchip web site ([www.microchip.com/PIC32](http://www.microchip.com/PIC32)).

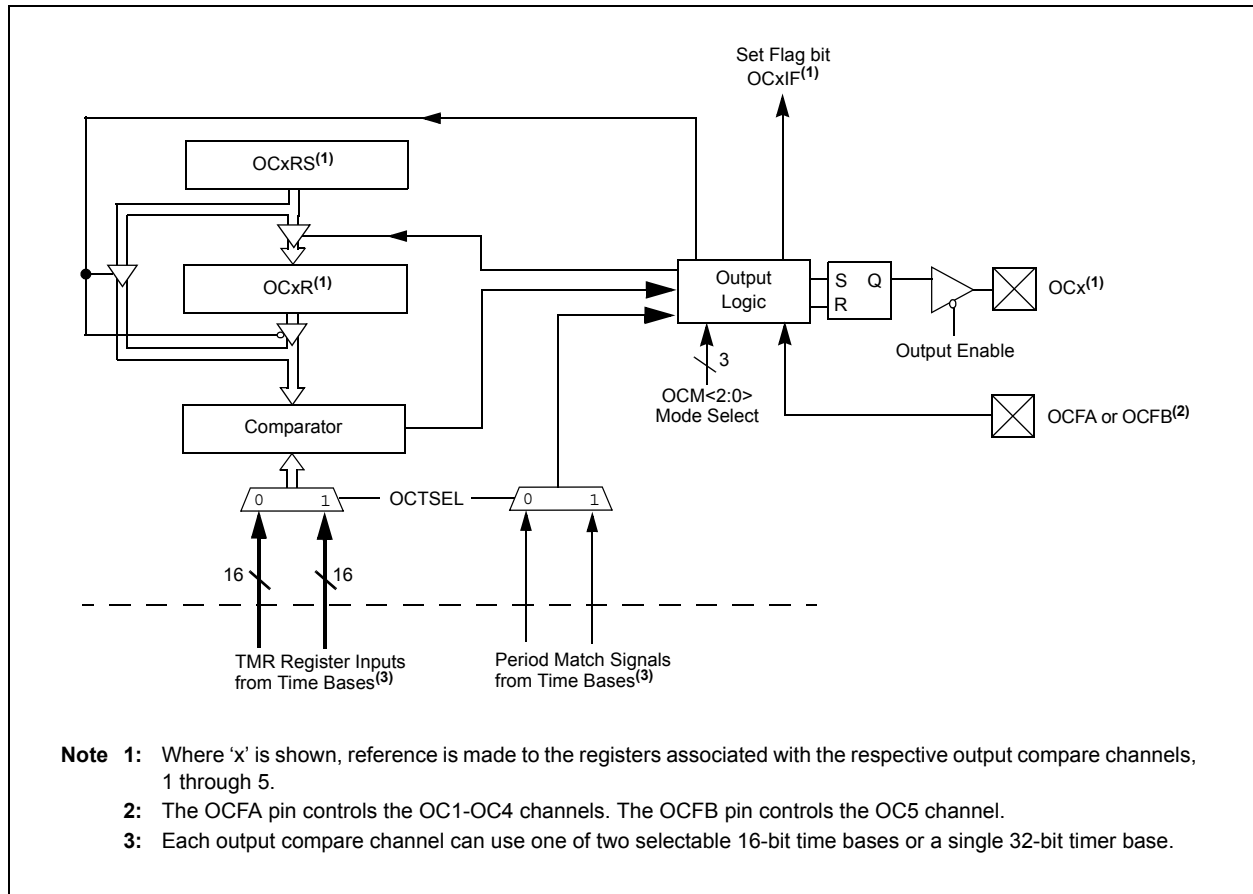
**2:** Some registers and associated bits described in this section may not be available on all devices. Refer to **Section 4.0 “Memory Organization”** in this data sheet for device-specific register and bit information.

The Output Compare module (OCMP) is used to generate a single pulse or a train of pulses in response to selected time base events. For all modes of operation, the OCMP module compares the values stored in the OCxR and/or the OCxRS registers to the value in the selected timer. When a match occurs, the OCMP module generates an event based on the selected mode of operation.

The following are some of the key features:

- Multiple Output Compare Modules in a device
- Programmable interrupt generation on compare event
- Single and Dual Compare modes
- Single and continuous output pulse generation
- Pulse-Width Modulation (PWM) mode
- Hardware-based PWM Fault detection and automatic output disable
- Programmable selection of 16-bit or 32-bit time bases
- Can operate from either of two available 16-bit time bases or a single 32-bit time base

**FIGURE 16-1: OUTPUT COMPARE MODULE BLOCK DIAGRAM**



# PIC32MX5XX/6XX/7XX

---

NOTES:

## 17.0 SERIAL PERIPHERAL INTERFACE (SPI)

**Note 1:** This data sheet summarizes the features of the PIC32MX5XX/6XX/7XX family of devices. It is not intended to be a comprehensive reference source. To complement the information in this data sheet, refer to **Section 23. “Serial Peripheral Interface (SPI)”** (DS61106) in the “PIC32MX Family Reference Manual”, which is available from the Microchip web site ([www.microchip.com/PIC32](http://www.microchip.com/PIC32)).

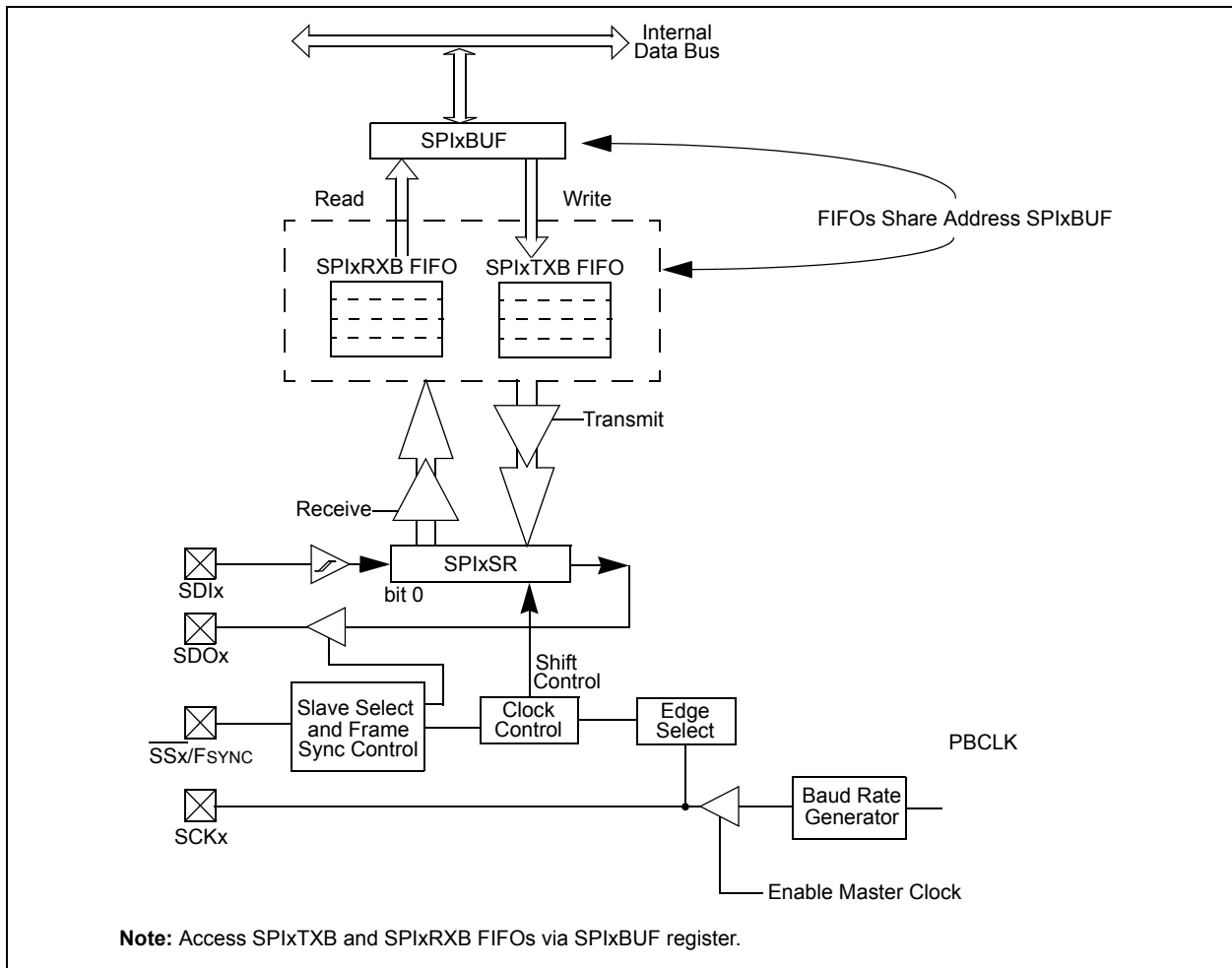
**2:** Some registers and associated bits described in this section may not be available on all devices. Refer to **Section 4.0 “Memory Organization”** in this data sheet for device-specific register and bit information.

The SPI module is a synchronous serial interface that is useful for communicating with external peripherals and other microcontroller devices. These peripheral devices may be Serial EEPROMs, Shift registers, display drivers, A/D Converters, etc. The PIC32MX SPI module is compatible with Motorola® SPI and SIOP interfaces.

Following are some of the key features of this module:

- Master and Slave modes support
- Four different clock formats
- Enhanced Framed SPI protocol support
- User-configurable 8-bit, 16-bit and 32-bit data width
- Separate SPI FIFO buffers for receive and transmit
  - FIFO buffers act as 4/8/16-level deep FIFOs based on 32/16/8-bit data width
- Programmable interrupt event on every 8-bit, 16-bit and 32-bit data transfer
- Operation during CPU Sleep and Idle mode
- Fast bit manipulation using CLR, SET and INV registers

**FIGURE 17-1: SPI MODULE BLOCK DIAGRAM**



# PIC32MX5XX/6XX/7XX

---

NOTES:

## 18.0 INTER-INTEGRATED CIRCUIT (I<sup>2</sup>C™)

**Note 1:** This data sheet summarizes the features of the PIC32MX5XX/6XX/7XX family of devices. It is not intended to be a comprehensive reference source. To complement the information in this data sheet, refer to **Section 24. “Inter-Integrated Circuit”** (DS61116) in the *“PIC32MX Family Reference Manual”*, which is available from the Microchip web site ([www.microchip.com/PIC32](http://www.microchip.com/PIC32)).

**2:** Some registers and associated bits described in this section may not be available on all devices. Refer to **Section 4.0 “Memory Organization”** in this data sheet for device-specific register and bit information.

The I<sup>2</sup>C module provides complete hardware support for both Slave and Multi-Master modes of the I<sup>2</sup>C serial communication standard. Figure 18-1 illustrates the I<sup>2</sup>C module block diagram.

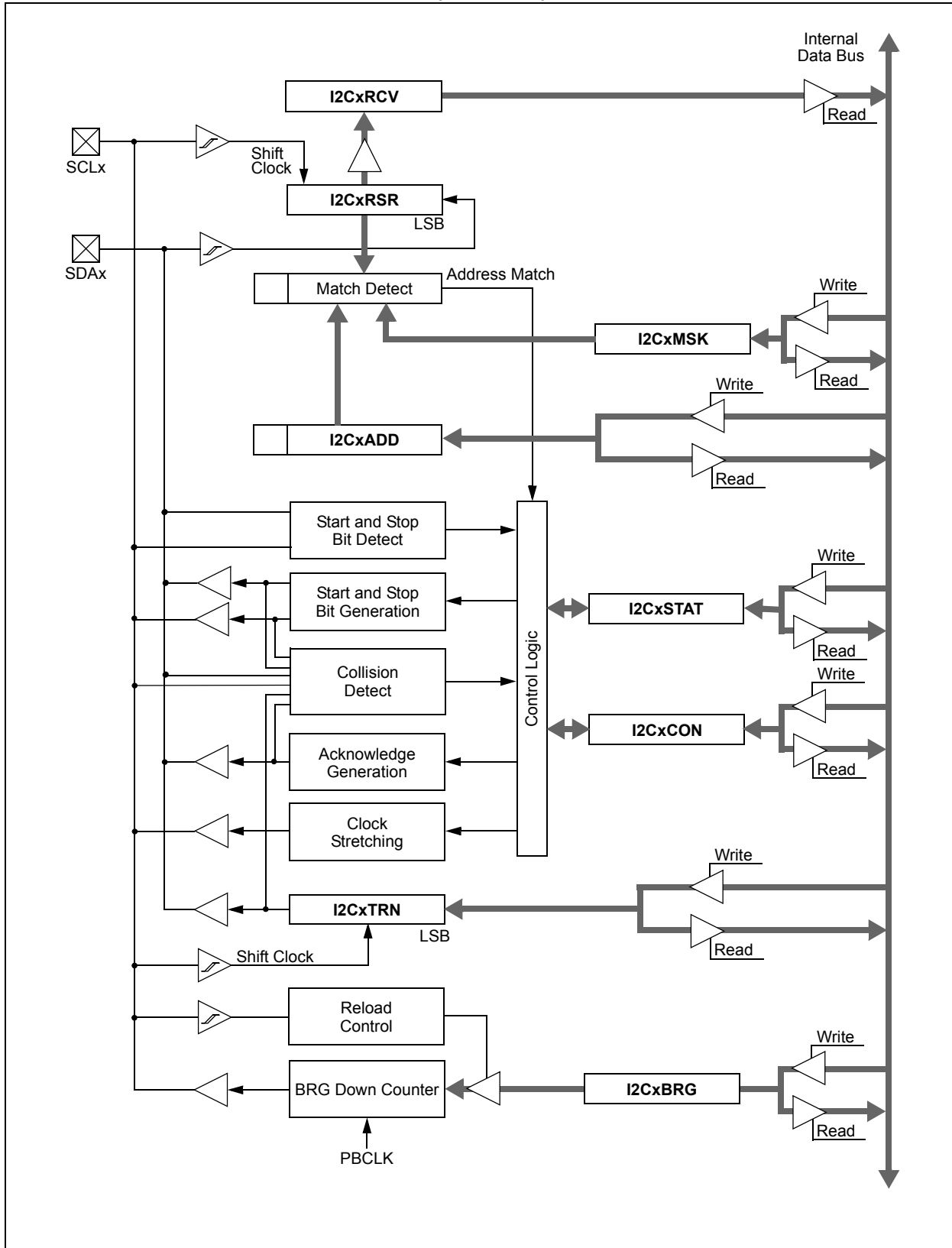
Each I<sup>2</sup>C module has a 2-pin interface: the SCLx pin is clock and the SDAx pin is data.

Each I<sup>2</sup>C module offers the following key features:

- I<sup>2</sup>C interface supporting both master and slave operation
- I<sup>2</sup>C Slave mode supports 7-bit and 10-bit addresses
- I<sup>2</sup>C Master mode supports 7-bit and 10-bit addresses
- I<sup>2</sup>C port allows bidirectional transfers between master and slaves
- Serial clock synchronization for the I<sup>2</sup>C port can be used as a handshake mechanism to suspend and resume serial transfer (SCLREL control)
- I<sup>2</sup>C supports multi-master operation; detects bus collision and arbitrates accordingly
- Provides support for address bit masking

# PIC32MX5XX/6XX/7XX

FIGURE 18-1: I<sup>2</sup>C™ BLOCK DIAGRAM (x = 1 OR 2)





## 19.0 UNIVERSAL ASYNCHRONOUS RECEIVER TRANSMITTER (UART)

**Note 1:** This data sheet summarizes the features of the PIC32MX5XX/6XX/7XX family of devices. It is not intended to be a comprehensive reference source. To complement the information in this data sheet, refer to **Section 21. “Universal Asynchronous Receiver Transmitter (UART)”** (DS61107) in the “PIC32MX Family Reference Manual”, which is available from the Microchip web site ([www.microchip.com/PIC32](http://www.microchip.com/PIC32)).

**Note 2:** Some registers and associated bits described in this section may not be available on all devices. Refer to **Section 4.0 “Memory Organization”** in this data sheet for device-specific register and bit information.

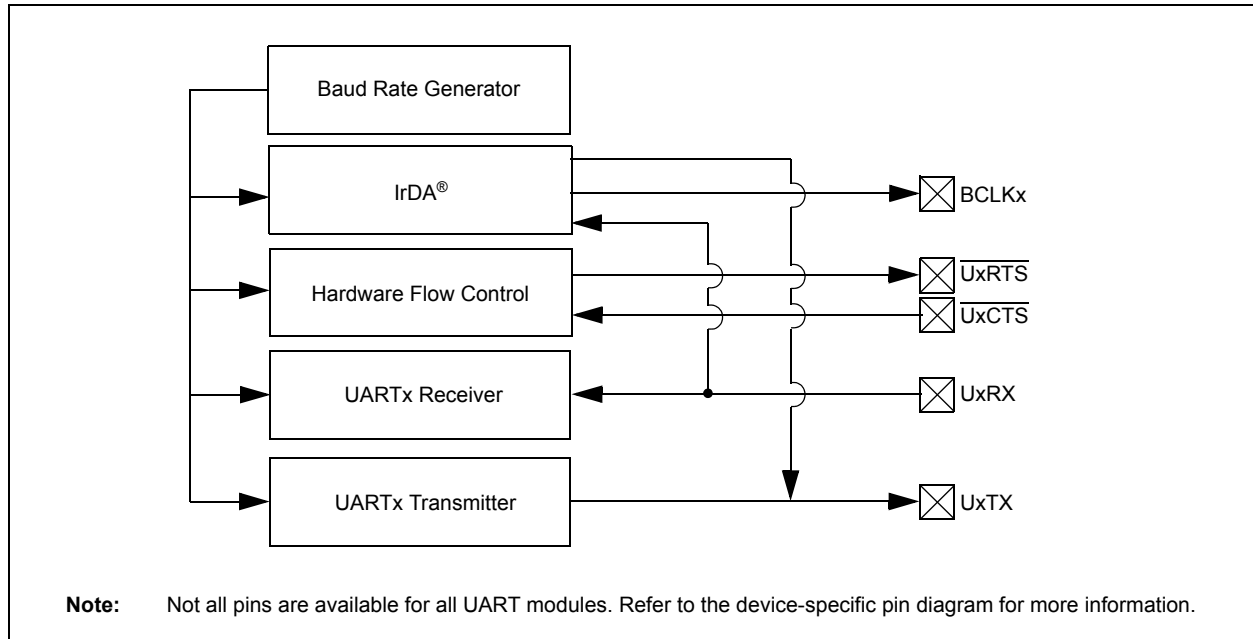
The UART module is one of the serial I/O modules available in PIC32MX5XX/6XX/7XX family devices. The UART is a full-duplex, asynchronous communication channel that communicates with peripheral devices and personal computers through protocols, such as RS-232, RS-485, LIN 1.2 and IrDA®. The module also supports the hardware flow control option, with UxCTS and UxRTS pins, and also includes an IrDA encoder and decoder.

The primary features of the UART module are:

- Full-duplex, 8-bit or 9-bit data transmission
- Even, Odd or No Parity options (for 8-bit data)
- One or two Stop bits
- Hardware auto-baud feature
- Hardware flow control option
- Fully integrated Baud Rate Generator (BRG) with 16-bit prescaler
- Baud rates ranging from 76 bps to 20 Mbps at 80 MHz
- 8-level deep First-In-First-Out (FIFO) transmit data buffer
- 8-level deep FIFO receive data buffer
- Parity, framing and buffer overrun error detection
- Support for interrupt-only on address detect (9th bit = 1)
- Separate transmit and receive interrupts
- Loopback mode for diagnostic support
- LIN 1.2 Protocol support
- IrDA encoder and decoder with 16x baud clock output for external IrDA encoder/decoder support

Figure 19-1 illustrates a simplified block diagram of the UART.

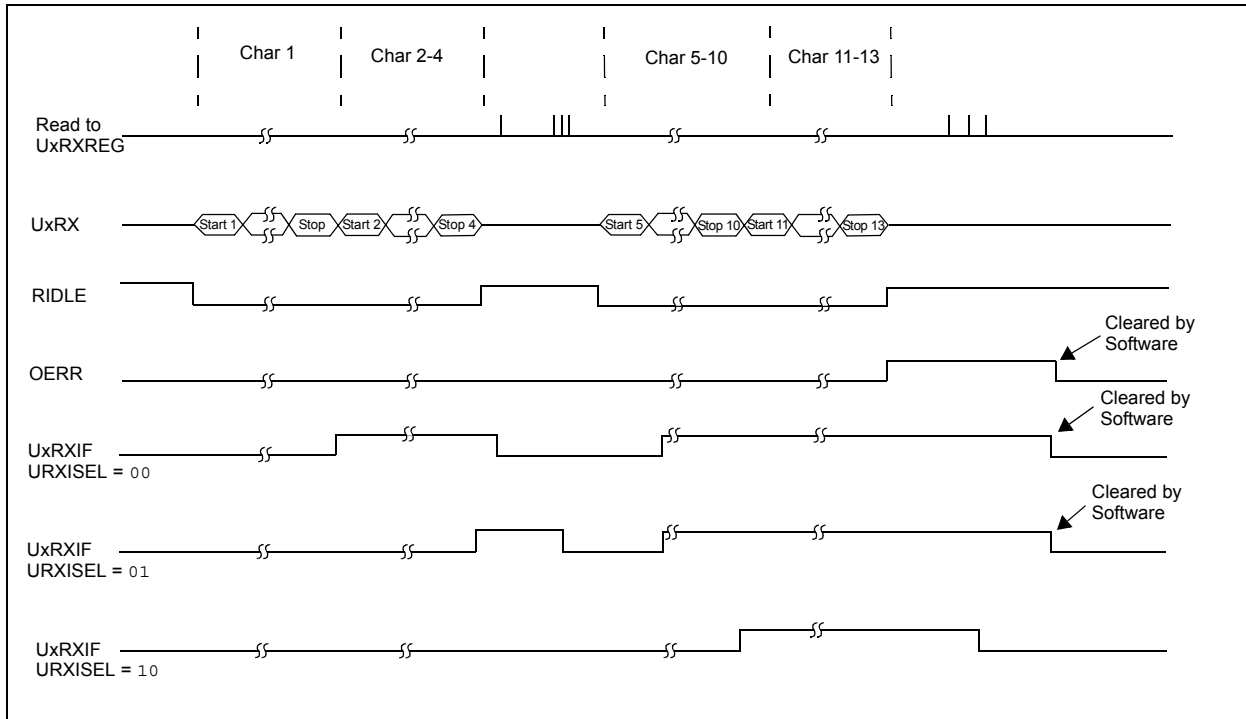
**FIGURE 19-1: UART SIMPLIFIED BLOCK DIAGRAM**



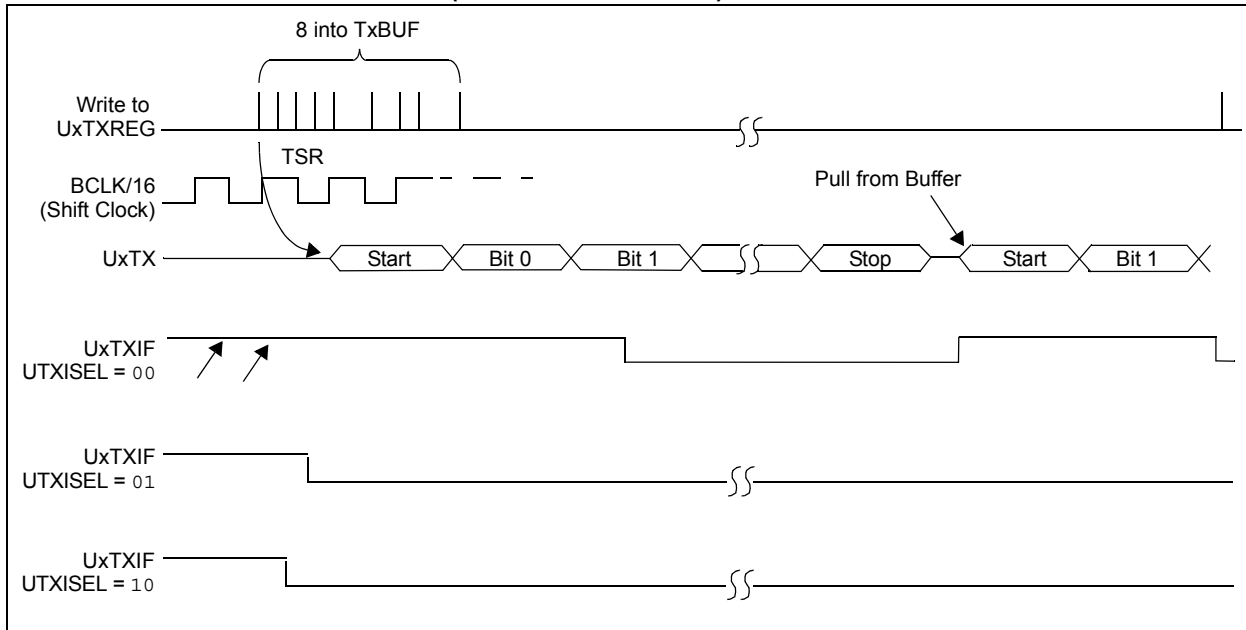
# PIC32MX5XX/6XX/7XX

Figure 19-2 and Figure 19-3 illustrate typical receive and transmit timing for the UART module.

**FIGURE 19-2: UART RECEPTION**



**FIGURE 19-3: TRANSMISSION (8-BIT OR 9-BIT DATA)**



## 20.0 PARALLEL MASTER PORT (PMP)

**Note 1:** This data sheet summarizes the features of the PIC32MX5XX/6XX/7XX family of devices. It is not intended to be a comprehensive reference source. To complement the information in this data sheet, refer to **Section 13. “Parallel Master Port (PMP)”** (DS61128) in the “PIC32MX Family Reference Manual”, which is available from the Microchip web site ([www.microchip.com/PIC32](http://www.microchip.com/PIC32)).

**2:** Some registers and associated bits described in this section may not be available on all devices. Refer to **Section 4.0 “Memory Organization”** in this data sheet for device-specific register and bit information.

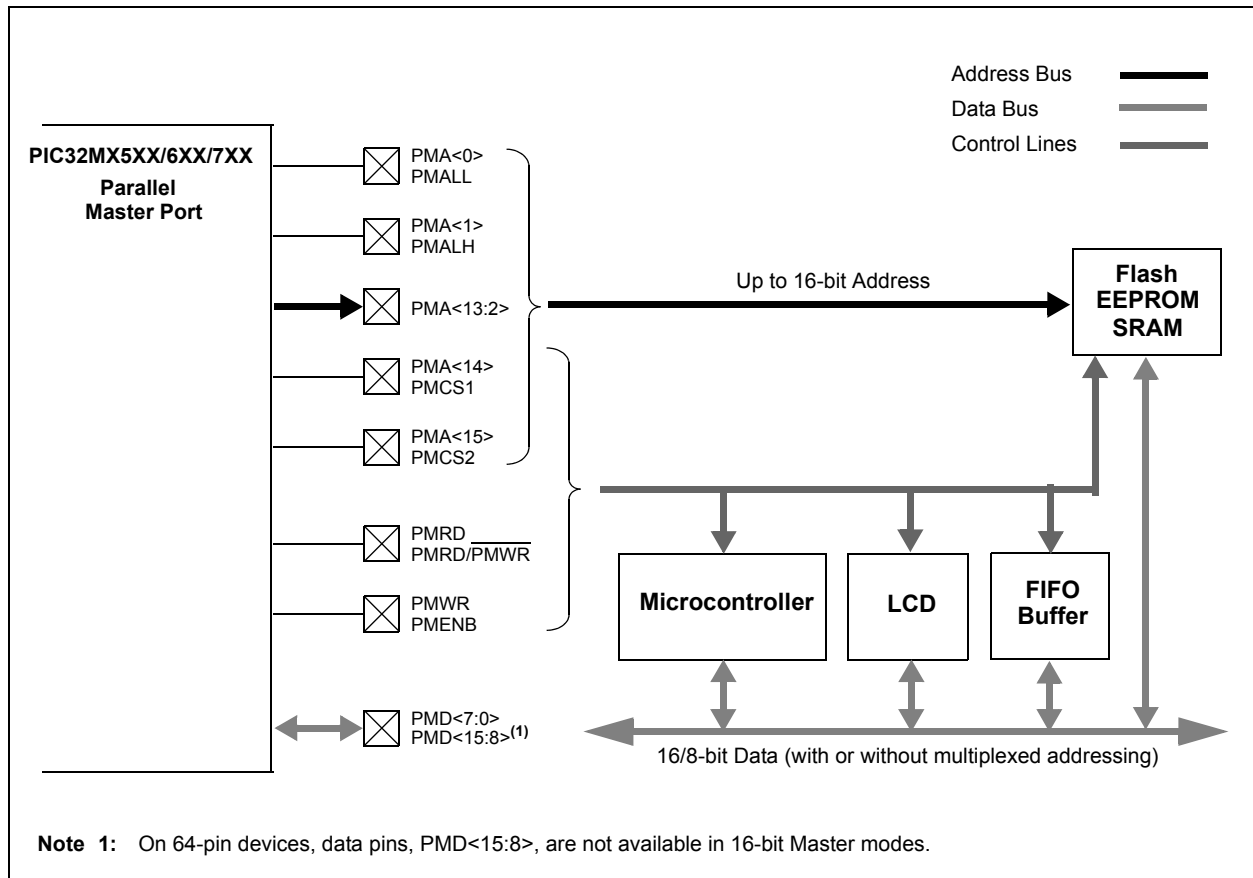
The PMP is a parallel 8-bit/16-bit input/output module specifically designed to communicate with a wide variety of parallel devices, such as communications peripherals, LCDs, external memory devices and microcontrollers. Because the interface to parallel peripherals varies significantly, the PMP module is highly configurable.

Key features of the PMP module include:

- 8-bit, 16-bit interface
- Up to 16 programmable address lines
- Up to two Chip Select lines
- Programmable strobe options
  - Individual read and write strobes, or
  - Read/write strobe with enable strobe
- Address auto-increment/auto-decrement
- Programmable address/data multiplexing
- Programmable polarity on control signals
- Parallel Slave Port support
  - Legacy addressable
  - Address support
  - 4-byte deep auto-incrementing buffer
- Programmable wait states
- Operates during CPU Sleep and Idle modes
- Fast bit manipulation using CLR, SET and INV registers
- Freeze option for in-circuit debugging

**Note:** On 64-pin devices, the PMD<15:8> data pins are not available.

**FIGURE 20-1: PMP MODULE PINOUT AND CONNECTIONS TO EXTERNAL DEVICES**



# PIC32MX5XX/6XX/7XX

---

NOTES:

## 21.0 REAL-TIME CLOCK AND CALENDAR (RTCC)

**Note 1:** This data sheet summarizes the features of the PIC32MX5XX/6XX/7XX family of devices. It is not intended to be a comprehensive reference source. To complement the information in this data sheet, refer to **Section 29. “Real-Time Clock and Calendar (RTCC)”** (DS61125) in the “PIC32MX Family Reference Manual”, which is available from the Microchip web site ([www.microchip.com/PIC32](http://www.microchip.com/PIC32)).

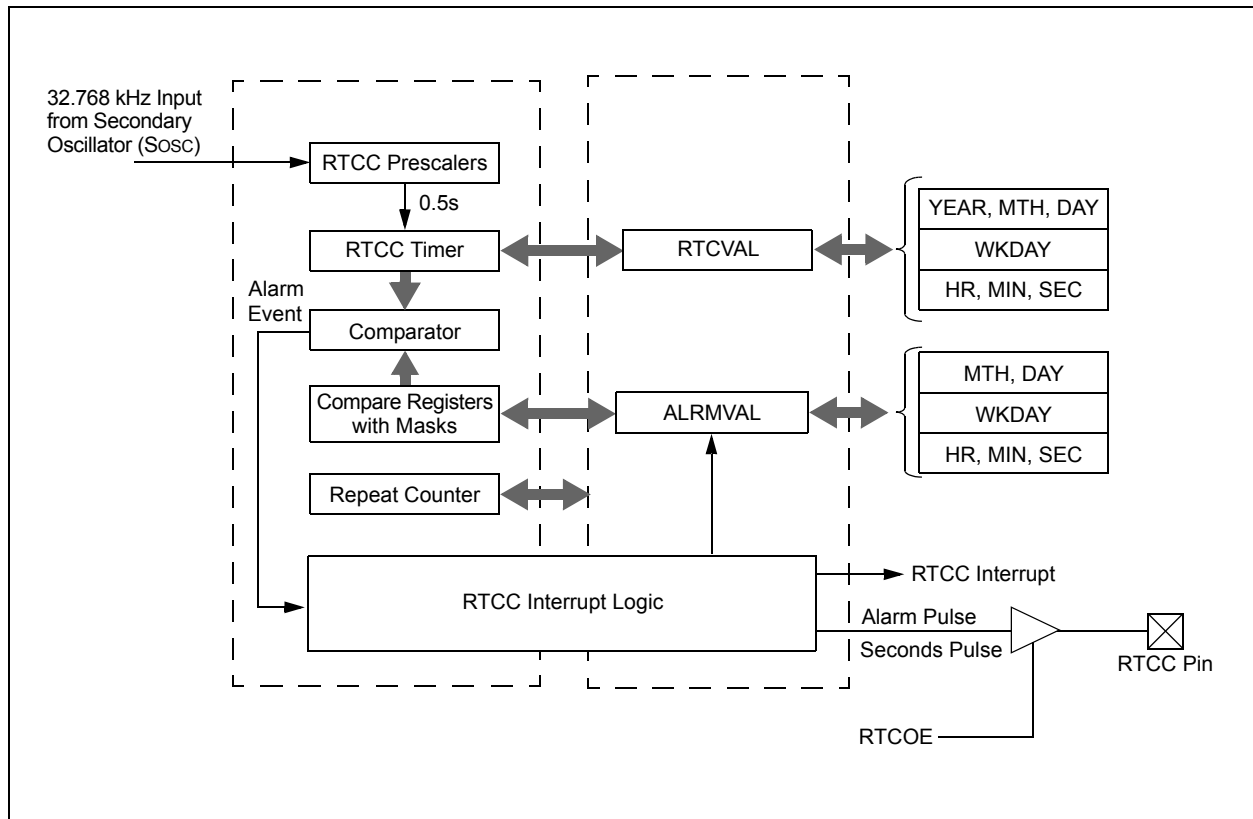
**2:** Some registers and associated bits described in this section may not be available on all devices. Refer to **Section 4.0 “Memory Organization”** in this data sheet for device-specific register and bit information.

The PIC32MX RTCC module is intended for applications in which accurate time must be maintained for extended periods of time with minimal or no CPU intervention. Low-power optimization provides extended battery lifetime while keeping track of time.

Following are some of the key features of this module:

- Time: hours, minutes and seconds
- 24-hour format (military time)
- Visibility of one-half second period
- Provides calendar: Weekday, date, month and year
- Alarm intervals are configurable for half of a second, one second, 10 seconds, one minute, 10 minutes, one hour, one day, one week, one month and one year
- Alarm repeat with decremting counter
- Alarm with indefinite repeat: Chime
- Year range: 2000 to 2099
- Leap year correction
- BCD format for smaller firmware overhead
- Optimized for long-term battery operation
- Fractional second synchronization
- User calibration of the clock crystal frequency with auto-adjust
- Calibration range:  $\pm 0.66$  seconds error per month
- Calibrates up to 260 ppm of crystal error
- Requirements: External 32.768 kHz clock crystal
- Alarm pulse or seconds clock output on RTCC pin

**FIGURE 21-1: RTCC BLOCK DIAGRAM**



# PIC32MX5XX/6XX/7XX

---

NOTES:

## 22.0 10-BIT ANALOG-TO-DIGITAL CONVERTER (ADC)

**Note 1:** This data sheet summarizes the features of the PIC32MX5XX/6XX/7XX family of devices. It is not intended to be a comprehensive reference source. To complement the information in this data sheet, refer to **Section 17. “10-bit Analog-to-Digital Converter (ADC)”** (DS61104) in the *“PIC32MX Family Reference Manual”*, which is available from the Microchip web site ([www.microchip.com/PIC32](http://www.microchip.com/PIC32)).

**2:** Some registers and associated bits described in this section may not be available on all devices. Refer to **Section 4.0 “Memory Organization”** in this data sheet for device-specific register and bit information.

The PIC32MX5XX/6XX/7XX 10-bit Analog-to-Digital (A/D) Converter (or ADC) includes the following features:

- Successive Approximation Register (SAR) conversion
- Up to 1 Msps conversion speed
- Up to 16 analog input pins
- External voltage reference input pins

- One unipolar, differential Sample and Hold Amplifier (SHA)
- Automatic Channel Scan mode
- Selectable conversion trigger source
- 16-word conversion result buffer
- Selectable buffer fill modes
- Eight conversion result format options
- Operation during CPU Sleep and Idle modes

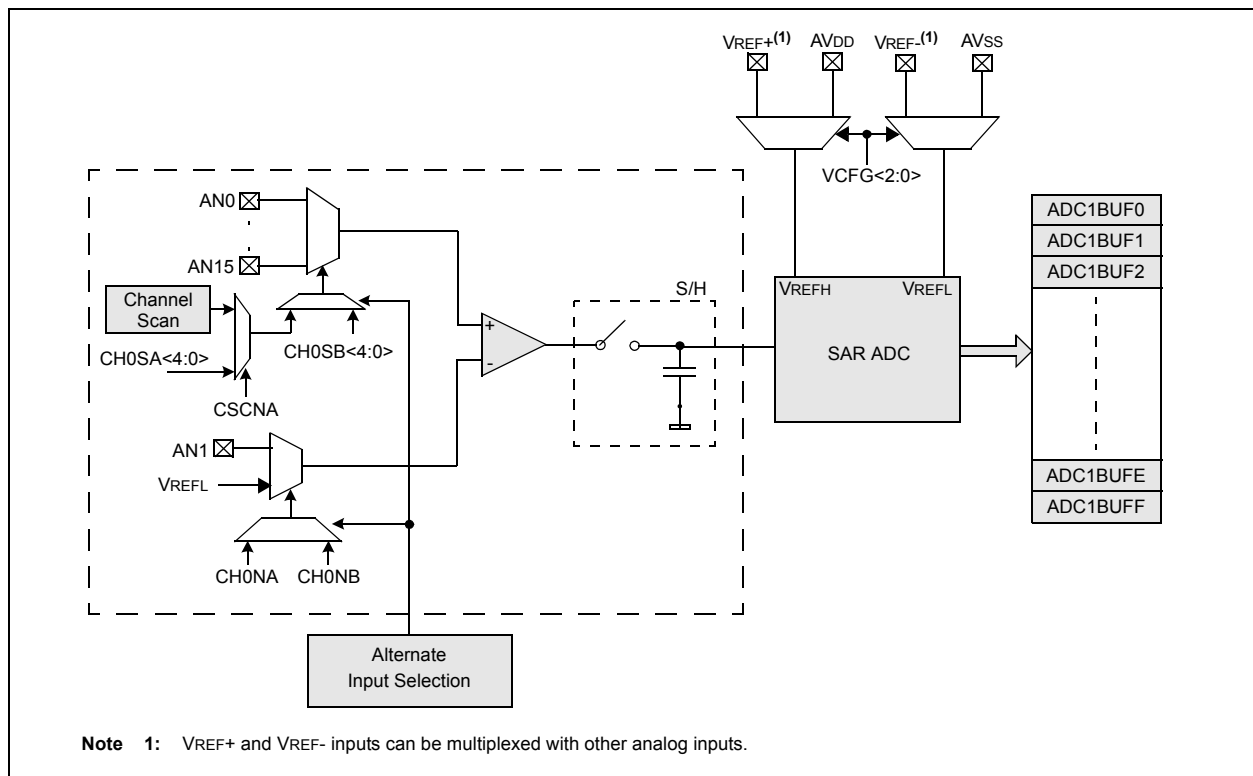
A block diagram of the 10-bit ADC is illustrated in Figure 22-1. The 10-bit ADC has up to 16 analog input pins, designated AN0-AN15. In addition, there are two analog input pins for external voltage reference connections. These voltage reference inputs may be shared with other analog input pins and may be common to other analog module references.

The analog inputs are connected through two multiplexers (MUXs) to one SHA. The analog input MUXs can be switched between two sets of analog inputs between conversions. Unipolar differential conversions are possible on all channels, other than the pin used as the reference, using a reference input pin (see Figure 22-1).

The Analog Input Scan mode sequentially converts user-specified channels. A control register specifies which analog input channels will be included in the scanning sequence.

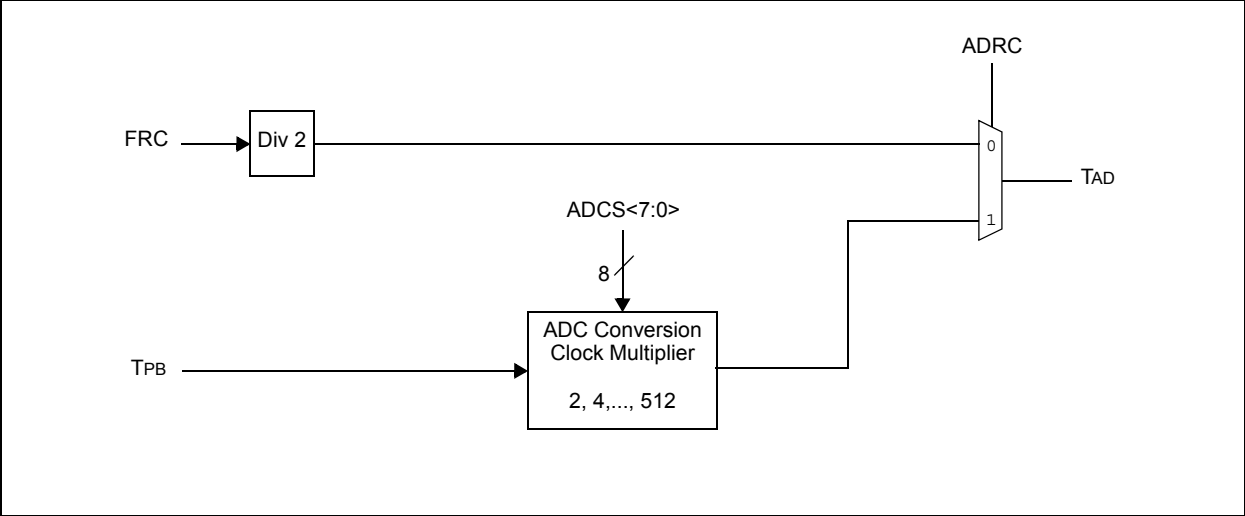
The 10-bit ADC is connected to a 16-word result buffer. Each 10-bit result is converted to one of eight 32-bit output formats when it is read from the result buffer.

**FIGURE 22-1: ADC1 MODULE BLOCK DIAGRAM**



# PIC32MX5XX/6XX/7XX

FIGURE 22-2: ADC CONVERSION CLOCK PERIOD BLOCK DIAGRAM





## 23.0 CONTROLLER AREA NETWORK (CAN)

**Note 1:** This data sheet summarizes the features of the PIC32MX5XX/6XX/7XX family of devices. It is not intended to be a comprehensive reference source. To complement the information in this data sheet, refer to **Section 34. “Controller Area Network (CAN)”** (DS61154) in the “PIC32MX Family Reference Manual”, which is available from the Microchip web site ([www.microchip.com/PIC32](http://www.microchip.com/PIC32)).

**2:** Some registers and associated bits described in this section may not be available on all devices. Refer to **Section 4.0 “Memory Organization”** in this data sheet for device-specific register and bit information.

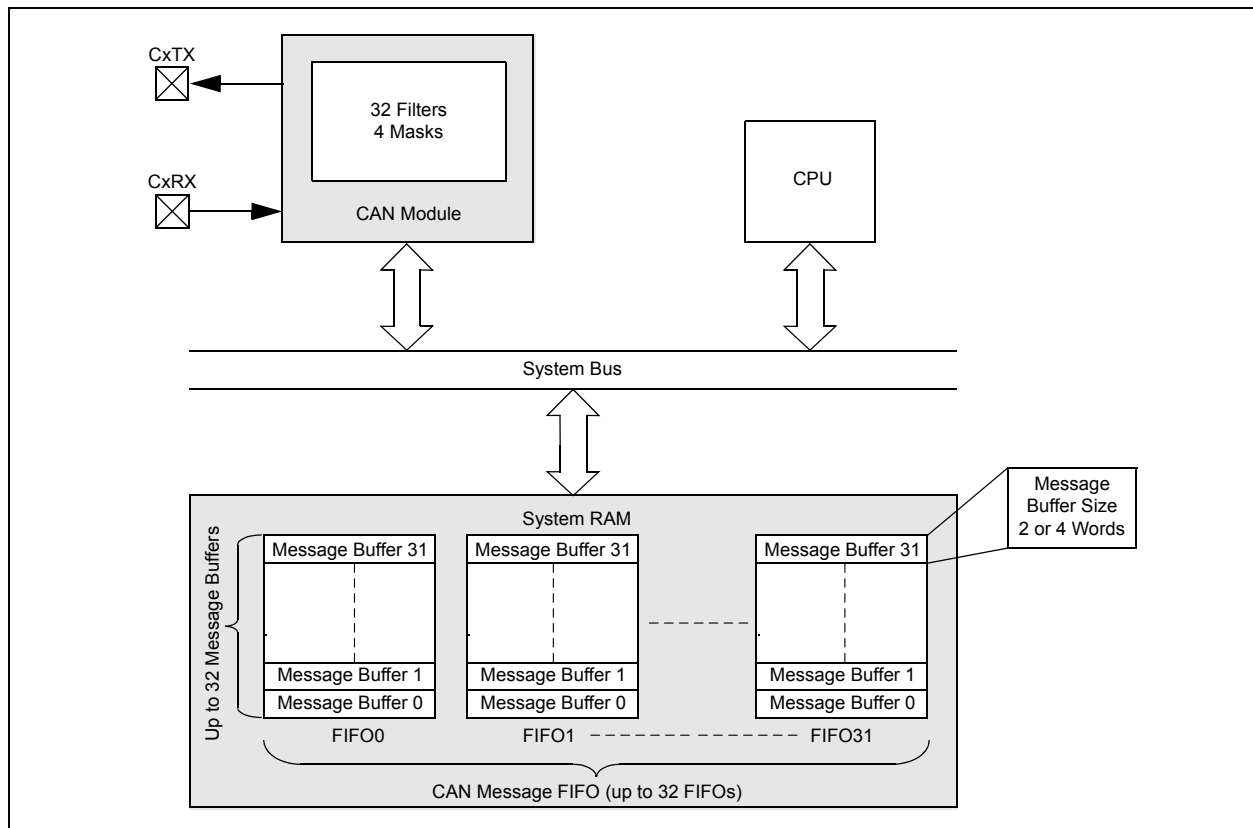
The Controller Area Network (CAN) module supports the following key features:

- Standards Compliance:
  - Full CAN 2.0B compliance
  - Programmable bit rate up to 1 Mbps

- Message Reception and Transmission:
  - 32 message FIFOs
  - Each FIFO can have up to 32 messages for a total of 1024 messages
  - FIFO can be a transmit message FIFO or a receive message FIFO
  - User-defined priority levels for message FIFOs used for transmission
  - 32 acceptance filters for message filtering
  - Four acceptance filter mask registers for message filtering
  - Automatic response to remote transmit request
  - DeviceNet™ addressing support
- Additional Features:
  - Loopback, Listen All Messages and Listen Only modes for self-test, system diagnostics and bus monitoring
  - Low-power operating modes
  - CAN module is a bus master on the PIC32MX system bus
  - Use of DMA is not required
  - Dedicated time-stamp timer
  - Dedicated DMA channels
  - Data-only Message Reception mode

Figure 23-1 illustrates the general structure of the CAN module.

**FIGURE 23-1: PIC32MX CAN MODULE BLOCK DIAGRAM**



# PIC32MX5XX/6XX/7XX

---

NOTES:

## 24.0 ETHERNET CONTROLLER

**Note 1:** This data sheet summarizes the features of the PIC32MX5XX/6XX/7XX family of devices. It is not intended to be a comprehensive reference source. To complement the information in this data sheet, refer to **Section 35. “Ethernet Controller”** (DS61155) in the *“PIC32MX Family Reference Manual”*, which is available from the Microchip web site ([www.microchip.com/PIC32](http://www.microchip.com/PIC32)).

**2:** Some registers and associated bits described in this section may not be available on all devices. Refer to **Section 4.0 “Memory Organization”** in this data sheet for device-specific register and bit information.

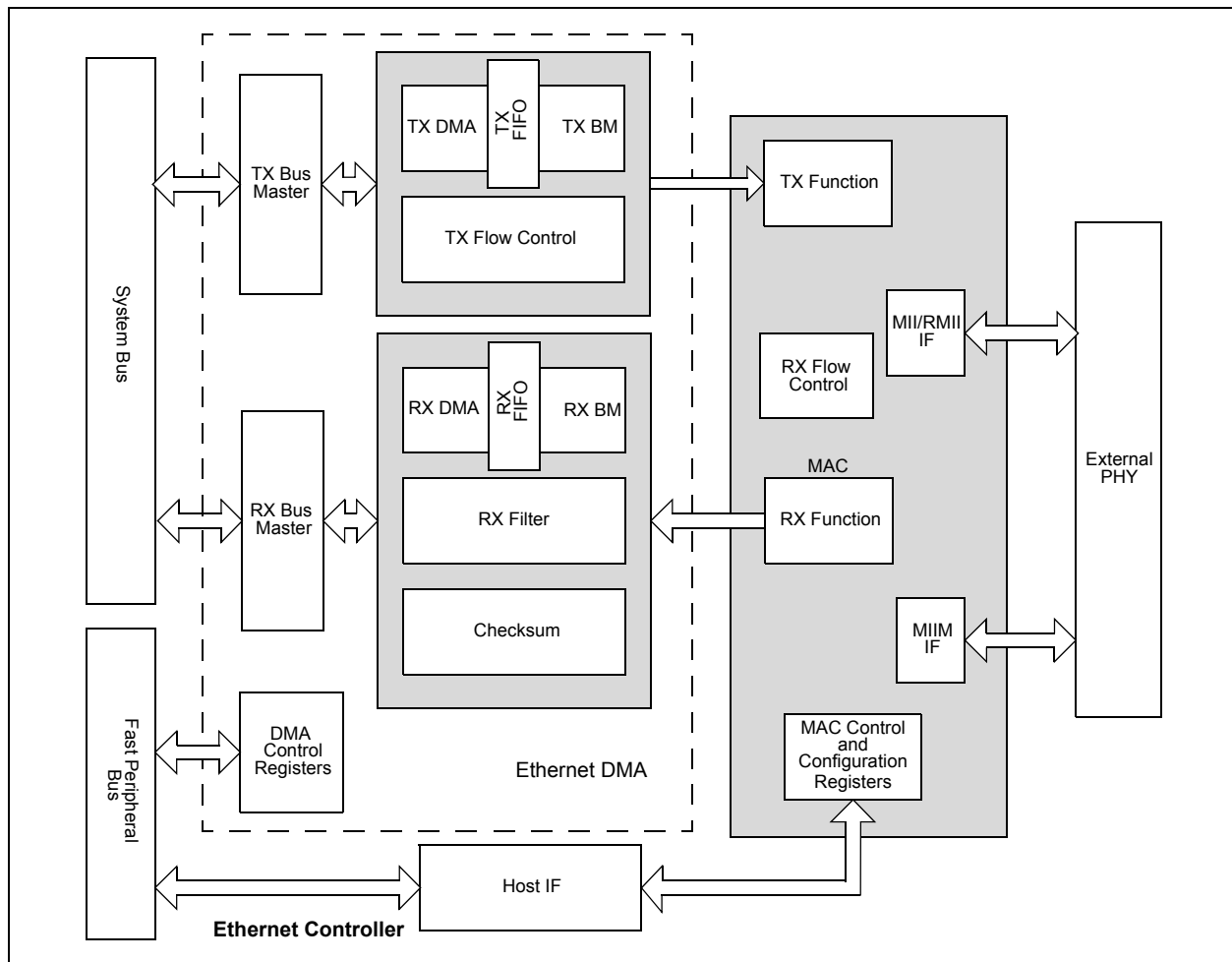
The Ethernet controller is a bus master module that interfaces with an off-chip Physical Layer (PHY) to implement a complete Ethernet node in a system.

Following are some of the key features of this module:

- Supports 10/100 Mbps data transfer rates
- Supports full-duplex and half-duplex operation
- Supports RMI and MII PHY interface
- Supports MIIM PHY management interface
- Supports both manual and automatic flow control
- RAM descriptor-based DMA operation for both receive and transmit path
- Fully configurable interrupts
- Configurable receive packet filtering
  - CRC check
  - 64-byte pattern match
  - Broadcast, multicast and unicast packets
  - Magic Packet™
  - 64-bit hash table
  - Runt packet
- Supports packet payload checksum calculation
- Supports various hardware statistics counters

Figure 24-1 illustrates a block diagram of the Ethernet controller.

**FIGURE 24-1: ETHERNET CONTROLLER BLOCK DIAGRAM**



# PIC32MX5XX/6XX/7XX

Table 24-1, Table 24-2, Table 24-3 and Table 24-4 show four interfaces and the associated pins that can be used with the Ethernet Controller.

**TABLE 24-1: MII MODE DEFAULT INTERFACE SIGNALS (FMIEN = 1, FETHIO = 1)**

Pin Name	Description
EMDC	Management Clock
EMDIO	Management I/O
ETXCLK	Transmit Clock
ETXEN	Transmit Enable
ETXD0	Transmit Data
ETXD1	Transmit Data
ETXD2	Transmit Data
ETXD3	Transmit Data
ETXERR	Transmit Error
ERXCLK	Receive Clock
ERXDV	Receive Data Valid
ERXD0	Receive Data
ERXD1	Receive Data
ERXD2	Receive Data
ERXD3	Receive Data
ERXERR	Receive Error
ECRS	Carrier Sense
ECOL	Collision Indication

**TABLE 24-3: MII MODE ALTERNATE INTERFACE SIGNALS (FMIEN = 1, FETHIO = 0)<sup>(1)</sup>**

Pin Name	Description
AEMDC	Management Clock
AEMDIO	Management I/O
AETXCLK	Transmit Clock
AETXEN	Transmit Enable
AETXD0	Transmit Data
AETXD1	Transmit Data
AETXD2	Transmit Data
AETXD3	Transmit Data
AETXERR	Transmit Error
AERXCLK	Receive Clock
AERXDV	Receive Data Valid
AERXD0	Receive Data
AERXD1	Receive Data
AERXD2	Receive Data
AERXD3	Receive Data
AERXERR	Receive Error
AECRS	Carrier Sense
AECOL	Collision Indication

**Note 1:** MII Alternate Interface is not available on 64-pin devices.

**TABLE 24-2: RMII MODE DEFAULT INTERFACE SIGNALS (FMIEN = 0, FETHIO = 1)**

Pin Name	Description
EMDC	Management Clock
EMDIO	Management I/O
ETXEN	Transmit Enable
ETXD0	Transmit Data
ETXD1	Transmit Data
EREFCLK	Reference Clock
ECRSDV	Carrier Sense – Receive Data Valid
ERXD0	Receive Data
ERXD1	Receive Data
ERXERR	Receive Error

**TABLE 24-4: RMII MODE ALTERNATE INTERFACE SIGNALS (FMIEN = 0, FETHIO = 0)**

Pin Name	Description
AEMDC	Management Clock
AEMDIO	Management I/O
AETXEN	Transmit Enable
AETXD0	Transmit Data
AETXD1	Transmit Data
AEREFCLK	Reference Clock
AECRSDV	Carrier Sense – Receive Data Valid
AERXD0	Receive Data
AERXD1	Receive Data
AERXERR	Receive Error

## 25.0 COMPARATOR

**Note 1:** This data sheet summarizes the features of the PIC32MX5XX/6XX/7XX family of devices. It is not intended to be a comprehensive reference source. To complement the information in this data sheet, refer to **Section 19. “Comparator”** (DS61110) in the “PIC32MX Family Reference Manual”, which is available from the Microchip web site ([www.microchip.com/PIC32](http://www.microchip.com/PIC32)).

**2:** Some registers and associated bits described in this section may not be available on all devices. Refer to **Section 4.0 “Memory Organization”** in this data sheet for device-specific register and bit information.

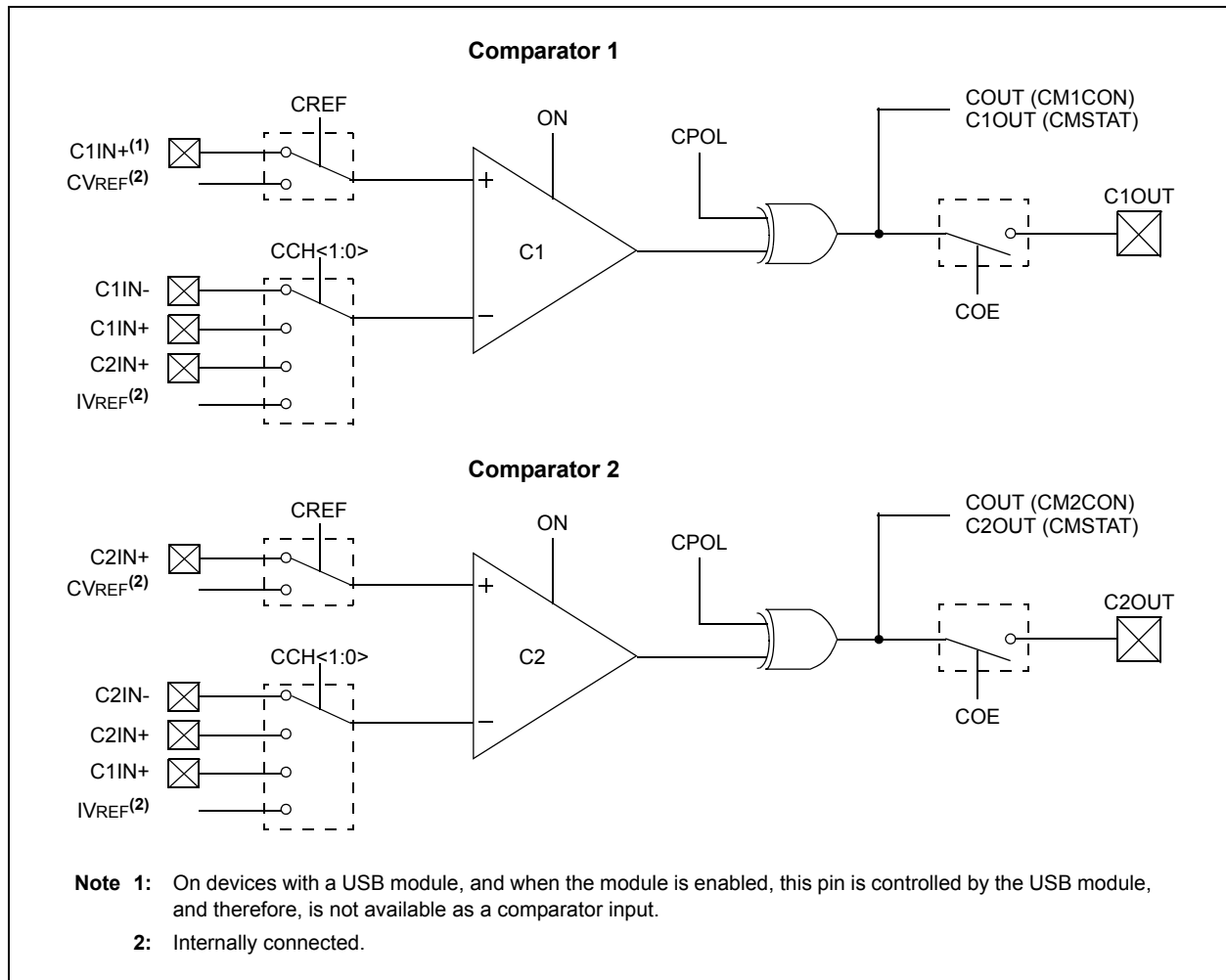
The PIC32MX5XX/6XX/7XX analog comparator module contains two comparators that can be configured in a variety of ways.

Following are some of the key features of this module:

- Selectable inputs available include:
  - Analog inputs multiplexed with I/O pins
  - On-chip internal absolute voltage reference (IVREF)
  - Comparator voltage reference (CVREF)
- Outputs can be Inverted
- Selectable interrupt generation

A block diagram of the comparator module is illustrated in Figure 25-1.

**FIGURE 25-1: COMPARATOR BLOCK DIAGRAM**



# PIC32MX5XX/6XX/7XX

---

NOTES:

## 26.0 COMPARATOR VOLTAGE REFERENCE (CVREF)

**Note 1:** This data sheet summarizes the features of the PIC32MX5XX/6XX/7XX family of devices. It is not intended to be a comprehensive reference source. To complement the information in this data sheet, refer to **Section 20. “Comparator Voltage Reference (CVREF)”** (DS61109) in the “PIC32MX Family Reference Manual”, which is available from the Microchip web site ([www.microchip.com/PIC32](http://www.microchip.com/PIC32)).

**2:** Some registers and associated bits described in this section may not be available on all devices. Refer to **Section 4.0 “Memory Organization”** in this data sheet for device-specific register and bit information.

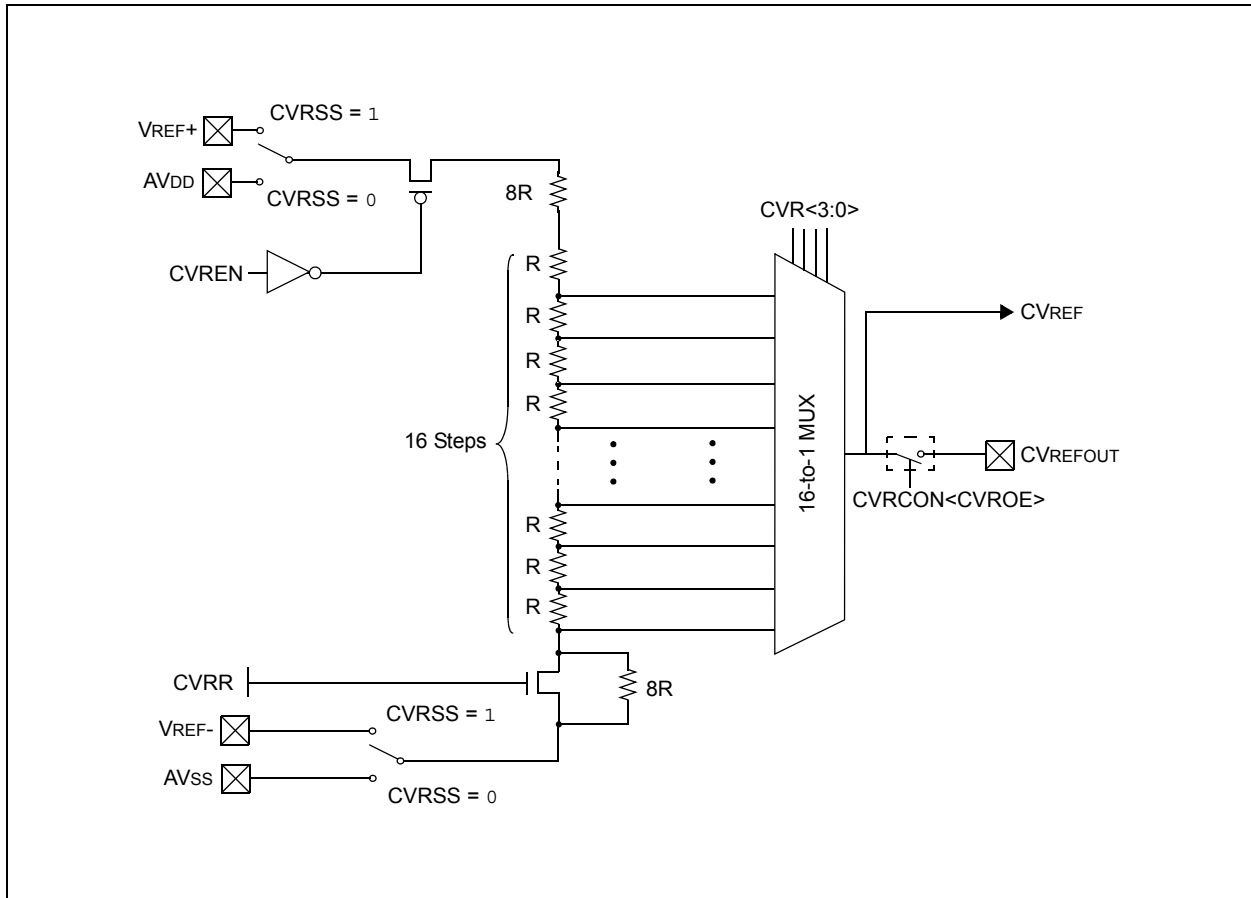
The CVREF module is a 16-tap, resistor ladder network that provides a selectable reference voltage. Although its primary purpose is to provide a reference for the analog comparators, it also may be used independently of them.

A block diagram of the module is illustrated in Figure 26-1. The resistor ladder is segmented to provide two ranges of voltage reference values and has a power-down function to conserve power when the reference is not being used. The module’s supply reference can be provided from either device VDD/VSS or an external voltage reference. The CVREF output is available for the comparators and typically available for pin output.

The comparator voltage reference has the following features:

- High and low range selection
- Sixteen output levels available for each range
- Internally connected to comparators to conserve device pins
- Output can be connected to a pin

**FIGURE 26-1: COMPARATOR VOLTAGE REFERENCE BLOCK DIAGRAM**



# PIC32MX5XX/6XX/7XX

---

NOTES:



## 27.0 POWER-SAVING FEATURES

**Note 1:** This data sheet summarizes the features of the PIC32MX5XX/6XX/7XX family of devices. It is not intended to be a comprehensive reference source. To complement the information in this data sheet, refer to **Section 10. “Power-Saving Features”** (DS61130) in the *“PIC32MX Family Reference Manual”*, which is available from the Microchip web site ([www.microchip.com/PIC32](http://www.microchip.com/PIC32)).

**2:** Some registers and associated bits described in this section may not be available on all devices. Refer to **Section 4.0 “Memory Organization”** in this data sheet for device-specific register and bit information.

This section describes power-saving features for the PIC32MX5XX/6XX/7XX. The PIC32MX devices offer a total of nine methods and modes, organized into two categories, that allow the user to balance power consumption with device performance. In all of the methods and modes described in this section, power-saving is controlled by software.

### 27.1 Power Saving with CPU Running

When the CPU is running, power consumption can be controlled by reducing the CPU clock frequency, lowering the PBCLK and by individually disabling modules. These methods are grouped into the following categories:

- FRC Run mode: the CPU is clocked from the FRC clock source with or without postscalers.
- LPRC Run mode: the CPU is clocked from the LPRC clock source.
- Sosc Run mode: the CPU is clocked from the Sosc clock source.

In addition, the Peripheral Bus Scaling mode is available where peripherals are clocked at the programmable fraction of the CPU clock (SYSCLK).

### 27.2 CPU Halted Methods

The device supports two power-saving modes, Sleep and Idle, both of which Halt the clock to the CPU. These modes operate with all clock sources, as listed below:

- Posc Idle mode: the system clock is derived from the Posc. The system clock source continues to operate.  
Peripherals continue to operate, but can optionally be individually disabled.
- FRC Idle mode: the system clock is derived from the FRC with or without postscalers.  
Peripherals continue to operate, but can optionally be individually disabled.

- Sosc Idle mode: the system clock is derived from the Sosc.  
Peripherals continue to operate, but can optionally be individually disabled.
- LPRC Idle mode: the system clock is derived from the LPRC.  
Peripherals continue to operate, but can optionally be individually disabled. This is the lowest power mode for the device with a clock running.
- Sleep mode: the CPU, the system clock source and any peripherals that operate from the system clock source are Halted.  
Some peripherals can operate in Sleep using specific clock sources. This is the lowest power mode for the device.

### 27.3 Power-Saving Operation

Peripherals and the CPU can be Halted or disabled to further reduce power consumption.

#### 27.3.1 SLEEP MODE

Sleep mode has the lowest power consumption of the device power-saving operating modes. The CPU and most peripherals are Halted. Select peripherals can continue to operate in Sleep mode and can be used to wake the device from Sleep. See the individual peripheral module sections for descriptions of behavior in Sleep.

Sleep mode includes the following characteristics:

- The CPU is Halted.
- The system clock source is typically shutdown. See **Section 27.3.3 “Peripheral Bus Scaling Method”** for specific information.
- There can be a wake-up delay based on the oscillator selection.
- The Fail-Safe Clock Monitor (FSCM) does not operate during Sleep mode.
- The BOR circuit, if enabled, remains operative during Sleep mode.
- The WDT, if enabled, is not automatically cleared prior to entering Sleep mode.
- Some peripherals can continue to operate at limited functionality in Sleep mode. These peripherals include I/O pins that detect a change in the input signal, WDT, ADC, UART and peripherals that use an external clock input or the internal LPRC oscillator (e.g., RTCC, Timer1 and Input Capture).
- I/O pins continue to sink or source current in the same manner as they do when the device is not in Sleep.
- The USB module can override the disabling of the Posc or FRC. Refer to the USB section for specific details.
- Modules can be individually disabled by software prior to entering Sleep in order to further reduce consumption.

# PIC32MX5XX/6XX/7XX

The processor will exit, or 'wake-up', from Sleep on one of the following events:

- On any interrupt from an enabled source that is operating in Sleep. The interrupt priority must be greater than the current CPU priority.
- On any form of device Reset.
- On a WDT time-out.

If the interrupt priority is lower than or equal to the current priority, the CPU will remain Halted, but the PBCLK will start running and the device will enter into Idle mode.

## 27.3.2 IDLE MODE

In Idle mode, the CPU is Halted but the System Clock (SYSCLK) source is still enabled. This allows peripherals to continue operation when the CPU is Halted. Peripherals can be individually configured to Halt when entering Idle by setting their respective SIDL bit. Latency, when exiting Idle mode, is very low due to the CPU oscillator source remaining active.

**Notes:** Changing the PBCLK divider ratio requires recalculation of peripheral timing. For example, assume the UART is configured for 9600 baud with a PB clock ratio of 1:1 and a POSC of 8 MHz. When the PB clock divisor of 1:2 is used, the input frequency to the baud clock is cut in half; therefore, the baud rate is reduced to 1/2 its former value. Due to numeric truncation in calculations (such as the baud rate divisor), the actual baud rate may be a tiny percentage different than expected. For this reason, any timing calculation required for a peripheral should be performed with the new PB clock frequency instead of scaling the previous value based on a change in the PB divisor ratio.

Oscillator start-up and PLL lock delays are applied when switching to a clock source that was disabled and that uses a crystal and/or the PLL. For example, assume the clock source is switched from POSC to LPRC just prior to entering Sleep in order to save power. No oscillator start-up delay would be applied when exiting Idle. However, when switching back to POSC, the appropriate PLL and/or oscillator start-up/lock delays would be applied.

The device enters Idle mode when the SLPEN (OSCCON<4>) bit is clear and a `WAIT` instruction is executed.

The processor will wake or exit from Idle mode on the following events:

- On any interrupt event for which the interrupt source is enabled. The priority of the interrupt event must be greater than the current priority of the CPU. If the priority of the interrupt event is lower than or equal to current priority of the CPU, the CPU will remain Halted and the device will remain in Idle mode.
- On any form of device Reset
- On a WDT time-out interrupt

## 27.3.3 PERIPHERAL BUS SCALING METHOD

Most of the peripherals on the device are clocked using the PBCLK. The peripheral bus can be scaled relative to the SYSCLK to minimize the dynamic power consumed by the peripherals. The PBCLK divisor is controlled by PBDIV<1:0> (OSCCON<20:19>), allowing SYSCLK to PBCLK ratios of 1:1, 1:2, 1:4 and 1:8. All peripherals using PBCLK are affected when the divisor is changed. Peripherals such as USB, interrupt controller, DMA, bus matrix and prefetch cache are clocked directly from SYSCLK. As a result, they are not affected by PBCLK divisor changes.

Changing the PBCLK divisor affects:

- The CPU to peripheral access latency. The CPU has to wait for next PBCLK edge for a read to complete. In 1:8 mode, this results in a latency of one to seven SYSCLKs.
- The power consumption of the peripherals. Power consumption is directly proportional to the frequency at which the peripherals are clocked. The greater the divisor, the lower the power consumed by the peripherals.

To minimize dynamic power, the PB divisor should be chosen to run the peripherals at the lowest frequency that provides acceptable system performance. When selecting a PBCLK divider, peripheral clock requirements, such as baud rate accuracy, should be taken into account. For example, the UART peripheral may not be able to achieve all baud rate values at some PBCLK divider depending on the SYSCLK value.

## 28.0 SPECIAL FEATURES

**Note:** This data sheet summarizes the features of the PIC32MX5XX/6XX/7XX family of devices. It is not intended to be a comprehensive reference source. To complement the information in this data sheet, refer to the related section in the “PIC32MX Family Reference Manual” (DS61132), which is available from the Microchip web site ([www.microchip.com/PIC32](http://www.microchip.com/PIC32)).

PIC32MX5XX/6XX/7XX devices include several features intended to maximize application flexibility and reliability and minimize cost through elimination of external components. These are:

- Flexible device configuration
- Watchdog Timer (WDT)
- JTAG (Joint Test Action Group) interface
- In-Circuit Serial Programming™ (ICSP™)

### 28.1 Configuration Bits

The Configuration bits can be programmed to select various device configurations.

**REGISTER 28-1: DEVCFG0: DEVICE CONFIGURATION WORD 0**

r-0	r-1	r-1	R/P	r-1	r-1	r-1	R/P
—	—	—	CP	—	—	—	BWP
bit 31							bit 24

r-1	r-1	r-1	r-1	R/P	R/P	R/P	R/P
—	—	—	—	PWP<7:4>			
bit 23							bit 16

R/P	R/P	R/P	R/P	r-1	r-1	r-1	r-1
PWP<3:0>				—	—	—	—
bit 15							bit 8

r-1	r-1	r-1	r-1	R/P	r-1	R/P	R/P
—	—	—	—	ICESEL	—	DEBUG<1:0>	
bit 7							bit 0

**Legend:**

R = Readable bit                      W = Writable bit                      P = Programmable bit                      r = Reserved bit  
 U = Unimplemented bit                      -n = Bit Value at POR: ('0', '1', x = Unknown)

- bit 31                      **Reserved:** Write '0'
- bit 30-29                      **Reserved:** Write '1'
- bit 28                      **CP:** Code-Protect bit  
 Prevents boot and program Flash memory from being read or modified by an external programming device.  
 1 = Protection is disabled  
 0 = Protection is enabled
- bit 27-25                      **Reserved:** Write '1'
- bit 24                      **BWP:** Boot Flash Write-Protect bit  
 Prevents boot Flash memory from being modified during code execution.  
 1 = Boot Flash is writable  
 0 = Boot Flash is not writable
- bit 23-20                      **Reserved:** Write '1'

# PIC32MX5XX/6XX/7XX

---

## REGISTER 28-1: DEVCFG0: DEVICE CONFIGURATION WORD 0 (CONTINUED)

- bit 19-12     **PWP<7:0>**: Program Flash Write-Protect bits  
Prevents selected program Flash memory pages from being modified during code execution.  
The PWP bits represent the one's compliment of the number of write-protected program Flash memory pages.
- 11111111 = Disabled
  - 11111110 = 0xBD00\_0FFF
  - 11111101 = 0xBD00\_1FFF
  - 11111100 = 0xBD00\_2FFF
  - 11111011 = 0xBD00\_3FFF
  - 11111010 = 0xBD00\_4FFF
  - 11111001 = 0xBD00\_5FFF
  - 11111000 = 0xBD00\_6FFF
  - 11110111 = 0xBD00\_7FFF
  - 11110110 = 0xBD00\_8FFF
  - 11110101 = 0xBD00\_9FFF
  - 11110100 = 0xBD00\_AFFF
  - 11110011 = 0xBD00\_BFFF
  - 11110010 = 0xBD00\_CFFF
  - 11110001 = 0xBD00\_DFFF
  - 11110000 = 0xBD00\_EFFF
  - 11101111 = 0xBD00\_FFFF
  - 
  - 
  - 
  - 01111111 = 0xBD07\_FFFF
- bit 11-4     **Reserved**: Write '1'
- bit 3         **ICESEL**: In-Circuit Emulator/Debugger Communication Channel Select bit  
1 = PGEC2/PGED2 pair is used  
0 = PGEC1/PGED1 pair is used
- bit 2         **Reserved**: Write '1'
- bit 1-0     **DEBUG<1:0>**: Background Debugger Enable bits (forced to '11' if code-protect is enabled)  
11 = Debugger is disabled  
10 = Debugger is enabled  
01 = Reserved (same as '11' setting)  
00 = Reserved (same as '11' setting)

# PIC32MX5XX/6XX/7XX

## REGISTER 28-2: DEVCFG1: DEVICE CONFIGURATION WORD 1

r-1	r-1	r-1	r-1	r-1	r-1	r-1	r-1
—	—	—	—	—	—	—	—
bit 31						bit 24	

R/P	r-1	r-1	R/P	R/P	R/P	R/P	R/P
FWDTEN	—	—	WDTPS<4:0>				
bit 23						bit 16	

R/P	R/P	R/P	R/P	r-1	R/P	R/P	R/P
FCKSM<1:0>		FPBDIV<1:0>		—	OSCIOfNC	POSCMOD<1:0>	
bit 15						bit 8	

R/P	r-1	R/P	r-1	r-1	R/P	R/P	R/P
IESO	—	FSOSCEN	—	—	FNOSC<2:0>		
bit 7						bit 0	

### Legend:

R = Readable bit      W = Writable bit      P = Programmable bit      r = Reserved bit  
 U = Unimplemented bit      -n = Bit Value at POR: ('0', '1', x = Unknown)

- bit 31-24      **Reserved:** Write '1'
- bit 23      **FWDTEN:** Watchdog Timer Enable bit  
             1 = The WDT is enabled and cannot be disabled by software  
             0 = The WDT is not enabled; it can be enabled in software
- bit 22-21      **Reserved:** Write '1'
- bit 20-16      **WDTPS<4:0>:** Watchdog Timer Postscale Select bits  
             10100 = 1:1048576  
             10011 = 1:524288  
             10010 = 1:262144  
             10001 = 1:131072  
             10000 = 1:65536  
             01111 = 1:32768  
             01110 = 1:16384  
             01101 = 1:8192  
             01100 = 1:4096  
             01011 = 1:2048  
             01010 = 1:1024  
             01001 = 1:512  
             01000 = 1:256  
             00111 = 1:128  
             00110 = 1:64  
             00101 = 1:32  
             00100 = 1:16  
             00011 = 1:8  
             00010 = 1:4  
             00001 = 1:2  
             00000 = 1:1  
             All other combinations not shown result in operation = 10100

**Note 1:** Do not disable Posc (POSCMOD = 11) when using this oscillator source.

# PIC32MX5XX/6XX/7XX

---

## REGISTER 28-2: DEVCFG1: DEVICE CONFIGURATION WORD 1 (CONTINUED)

bit 15-14	<b>FCKSM&lt;1:0&gt;</b> : Clock Switching and Monitor Selection Configuration bits 1x = Clock switching is disabled, Fail-Safe Clock Monitor is disabled 01 = Clock switching is enabled, Fail-Safe Clock Monitor is disabled 00 = Clock switching is enabled, Fail-Safe Clock Monitor is enabled
bit 13-12	<b>FPBDIV&lt;1:0&gt;</b> : Peripheral Bus Clock Divisor Default Value bits 11 = PBCLK is SYSCLK divided by 8 10 = PBCLK is SYSCLK divided by 4 01 = PBCLK is SYSCLK divided by 2 00 = PBCLK is SYSCLK divided by 1
bit 11	<b>Reserved</b> : Write '1'
bit 10	<b>OSCIOFNC</b> : CLKO Enable Configuration bit 1 = CLKO output signal active on the OSCO pin; primary oscillator must be disabled or configured for the External Clock mode (EC) for the CLKO to be active (POSCMOD<1:0> = 11 or 00) 0 = CLKO output disabled
bit 9-8	<b>POSCMOD&lt;1:0&gt;</b> : Primary Oscillator Configuration bits 11 = Primary oscillator disabled 10 = HS Oscillator mode selected 01 = XT Oscillator mode selected 00 = External Clock mode selected
bit 7	<b>IESO</b> : Internal External Switchover bit 1 = Internal External Switchover mode is enabled (Two-Speed Start-up is enabled) 0 = Internal External Switchover mode is disabled (Two-Speed Start-up is disabled)
bit 6	<b>Reserved</b> : Write '1'
bit 5	<b>FSOSCEN</b> : Secondary Oscillator Enable bit 1 = Enable Secondary Oscillator 0 = Disable Secondary Oscillator
bit 4-3	<b>Reserved</b> : Write '1'
bit 2-0	<b>FNOSC&lt;2:0&gt;</b> : Oscillator Selection bits 111 = Fast RC Oscillator with divide-by-N (FRCDIV) 110 = FRCDIV16 Fast RC Oscillator with fixed divide-by-16 postscaler 101 = Low-Power RC Oscillator (LPRC) 100 = Secondary Oscillator (Sosc) 011 = Primary Oscillator with PLL module (XT+PLL, HS+PLL, EC+PLL) 010 = Primary Oscillator (XT, HS, EC) <sup>(1)</sup> 001 = Fast RC Oscillator with divide-by-N with PLL module (FRCDIV+PLL) 000 = Fast RC Oscillator (FRC)

**Note 1:** Do not disable Posc (POSCMOD = 11) when using this oscillator source.

# PIC32MX5XX/6XX/7XX

## REGISTER 28-3: DEVCFG2: DEVICE CONFIGURATION WORD 2

r-1	r-1	r-1	r-1	r-1	r-1	r-1	r-1
—	—	—	—	—	—	—	—
bit 31						bit 24	

r-1	r-1	r-1	r-1	r-1	R/P	R/P	R/P
—	—	—	—	—	FPLLODIV<2:0>		
bit 23						bit 16	

R/P	r-1	r-1	r-1	r-1	R/P	R/P	R/P
UPLLEN	—	—	—	—	UPLLDIV<2:0>		
bit 15						bit 8	

r-1	R/P-1	R/P	R/P-1	r-1	R/P	R/P	R/P
—	FPLLMUL<2:0>			—	FPLLDIV<2:0>		
bit 7						bit 0	

### Legend:

R = Readable bit      W = Writable bit      P = Programmable bit      r = Reserved bit  
 U = Unimplemented bit      -n = Bit Value at POR: ('0', '1', x = Unknown)

- bit 31-19      **Reserved:** Write '1'
- bit 18-16      **FPLLODIV<2:0>:** Default Postscaler for PLL bits
  - 111 = PLL output divided by 256
  - 110 = PLL output divided by 64
  - 101 = PLL output divided by 32
  - 100 = PLL output divided by 16
  - 011 = PLL output divided by 8
  - 010 = PLL output divided by 4
  - 001 = PLL output divided by 2
  - 000 = PLL output divided by 1
- bit 15      **UPLLEN:** USB PLL Enable bit
  - 1 = Enable USB PLL
  - 0 = Disable and bypass USB PLL
- bit 14-11      **Reserved:** Write '1'
- bit 10-8      **UPLLDIV<2:0>:** PLL Input Divider bits
  - 111 = 12x divider
  - 110 = 10x divider
  - 101 = 6x divider
  - 100 = 5x divider
  - 011 = 4x divider
  - 010 = 3x divider
  - 010 = 3x divider
  - 001 = 2x divider
  - 000 = 1x divider
- bit 7      **Reserved:** Write '1'

# PIC32MX5XX/6XX/7XX

---

## REGISTER 28-3: DEVCFG2: DEVICE CONFIGURATION WORD 2 (CONTINUED)

bit 6-4      **FPLLMUL<2:0>**: PLL Multiplier bits

111 = 24x multiplier

110 = 21x multiplier

101 = 20x multiplier

100 = 19x multiplier

011 = 18x multiplier

010 = 17x multiplier

001 = 16x multiplier

000 = 15x multiplier

bit 3      **Reserved**: Write '1'

bit 2-0      **FPLLIDIV<2:0>**: PLL Input Divider bits

111 = 12x divider

110 = 10x divider

101 = 6x divider

100 = 5x divider

011 = 4x divider

010 = 3x divider

001 = 2x divider

000 = 1x divider



# PIC32MX5XX/6XX/7XX

## REGISTER 28-4: DEVCFG3: DEVICE CONFIGURATION WORD 3

R/P	R/P	r-1	r-1	r-1	R/P	R/P	R/P
FVBUSONIO	FUSBIDIO	—	—	—	FCANIO	FETHIO	FMIEN
bit 31						bit 24	

r-1	r-1	r-1	r-1	r-1	R/P	R/P	R/P
—	—	—	—	—	FSRSSEL<2:0>		
bit 23						bit 16	

R/P	R/P	R/P	R/P	R/P	R/P	R/P	R/P
USERID<15:8>							
bit 15						bit 8	

R/P	R/P	R/P	R/P	R/P	R/P	R/P	R/P
USERID<7:0>							
bit 7						bit 0	

### Legend:

R = Readable bit      W = Writable bit      P = Programmable bit      r = Reserved bit  
 U = Unimplemented bit      -n = Bit Value at POR: ('0', '1', x = Unknown)

- bit 31      **FVBUSONIO:** USB VBUS\_ON Selection bit  
             1 = VBUSON pin is controlled by the USB module  
             0 = VBUSON pin is controlled by the port function
- bit 30      **FUSBIDIO:** USB USBID Selection bit  
             1 = USBID pin is controlled by the USB module  
             0 = USBID pin is controlled by the port function
- bit 29-27      **Reserved:** Write '1'
- bit 26      **FCANIO:** CAN I/O Pin Selection bit  
             1 = Default CAN I/O Pins  
             0 = Alternate CAN I/O Pins
- bit 25      **FETHIO:** Ethernet I/O Pin Selection bit  
             1 = Default Ethernet I/O Pins  
             0 = Alternate Ethernet I/O Pins
- bit 24      **FMIEN:** Ethernet MII Enable bit  
             1 = MII is enabled  
             0 = RMII is enabled
- bit 23-19      **Reserved:** Write '1'
- bit 18-16      **FSRSSEL<2:0>:** SRS Select bits  
             111 = Assign Interrupt Priority 7 to a shadow register set  
             110 = Assign Interrupt Priority 6 to a shadow register set  
             .  
             .  
             .  
             001 = Assign Interrupt Priority 1 to a shadow register set  
             000 = All interrupt priorities are assigned to a shadow register set
- bit 15-0      **USERID<15:0>:** This is a 16-bit value that is user-defined and is readable via ICSP™ and JTAG

# PIC32MX5XX/6XX/7XX

## REGISTER 28-5: DEVID: DEVICE AND REVISION ID REGISTER

R	R	R	R	R	R	R	R	R
VER<3:0> <sup>(1)</sup>				DEVID<27:24> <sup>(1)</sup>				
bit 31				bit 24				

R	R	R	R	R	R	R	R	R
DEVID<23:16> <sup>(1)</sup>								
bit 23				bit 16				

R	R	R	R	R	R	R	R	R
DEVID<15:8> <sup>(1)</sup>								
bit 15				bit 8				

R	R	R	R	R	R	R	R	R
DEVID<7:0> <sup>(1)</sup>								
bit 7				bit 0				

### Legend:

R = Readable bit      W = Writable bit      P = Programmable bit      r = Reserved bit  
 U = Unimplemented bit      -n = Bit Value at POR: ('0', '1', x = Unknown)

bit 31-28      **VER<3:0>**: Revision Identifier bits<sup>(1)</sup>

bit 27-0      **DEVID<27:0>**: Device ID<sup>(1)</sup>

**Note 1:** See the "PIC32MX Flash Programming Specification" (DS61145) for a list of Revision and Device ID values.

## 28.2 Watchdog Timer (WDT)

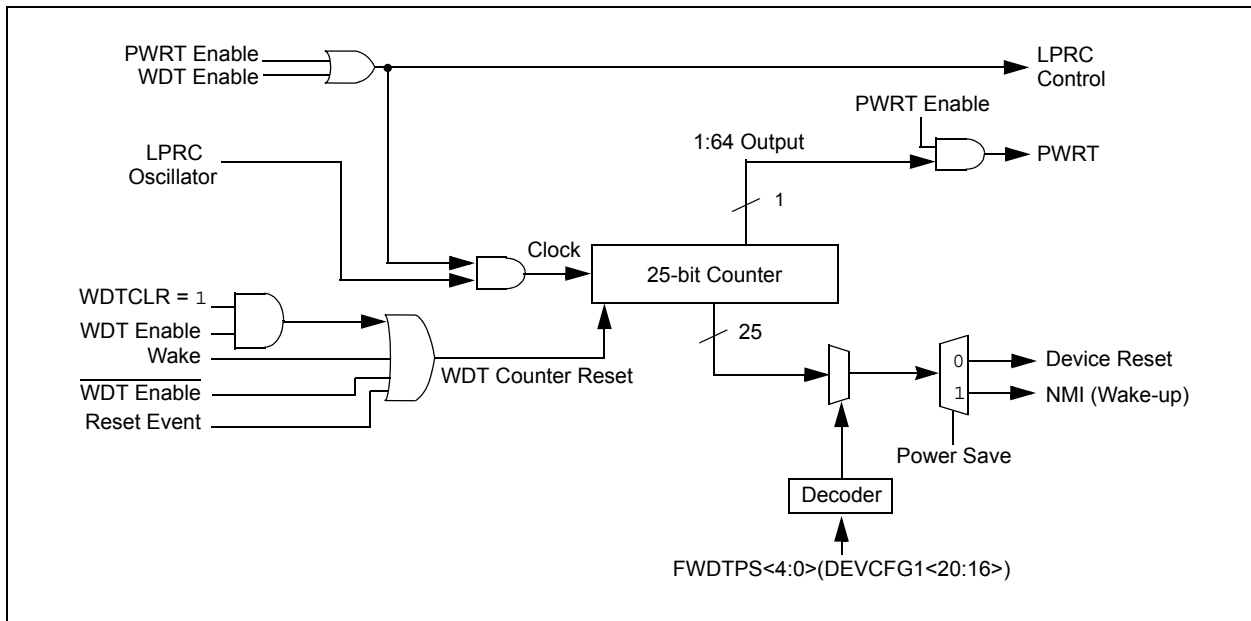
This section describes the operation of the WDT and Power-up Timer of the PIC32MX5XX/6XX/7XX.

The WDT, when enabled, operates from the internal Low-Power Oscillator (LPRC) clock source and can be used to detect system software malfunctions by resetting the device if the WDT is not cleared periodically in software. Various WDT time-out periods can be selected using the WDT postscaler. The WDT can also be used to wake the device from Sleep or Idle mode.

The following are some of the key features of the WDT module:

- Configuration or software controlled
- User-configurable time-out period
- Can wake the device from Sleep or Idle

**FIGURE 28-1: WATCHDOG AND POWER-UP TIMER BLOCK DIAGRAM**



# PIC32MX5XX/6XX/7XX

## 28.3 On-Chip Voltage Regulator

All PIC32MX5XX/6XX/7XX devices' core and digital logic are designed to operate at a nominal 1.8V. To simplify system designs, most devices in the PIC32MX5XX/6XX/7XX family incorporate an on-chip regulator providing the required core logic voltage from VDD.

A low-ESR capacitor (such as tantalum) must be connected to the VCAP/VDDCORE pin (see Figure 28-2). This helps to maintain the stability of the regulator. The recommended value for the filter capacitor is provided in **Section 31.1 "DC Characteristics"**.

**Note:** It is important that the low-ESR capacitor is placed as close as possible to the VCAP/VDDCORE pin.

### 28.3.1 ON-CHIP REGULATOR AND POR

It takes a fixed delay for the on-chip regulator to generate an output. During this time, designated as TPU, code execution is disabled. TPU is applied every time the device resumes operation after any power-down, including Sleep mode.

If the regulator is disabled, a separate Power-up Timer (PWRT) is automatically enabled. The PWRT adds a fixed delay of TPWRT at device start-up. See **Section 31.0 "Electrical Characteristics"** for more information on TPU AND TPWRT.

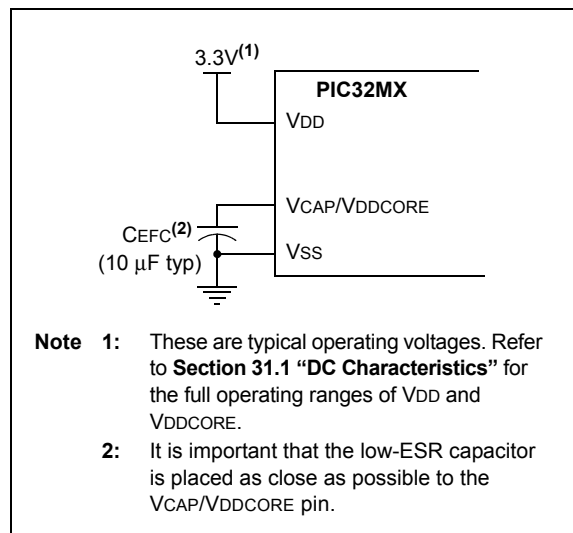
### 28.3.2 ON-CHIP REGULATOR AND BOR

PIC32MX5XX/6XX/7XX devices also have a simple brown-out capability. If the voltage supplied to the regulator is inadequate to maintain a regulated level, the regulator Reset circuitry will generate a Brown-out Reset. This event is captured by the BOR flag bit (RCON<1>). The brown-out voltage levels are specific in **Section 31.1 "DC Characteristics"**.

### 28.3.3 POWER-UP REQUIREMENTS

The on-chip regulator is designed to meet the power-up requirements for the device. If the application does not use the regulator, then strict power-up conditions must be adhered to. While powering up, VDDCORE must never exceed VDD by 0.3 volts.

**FIGURE 28-2: CONNECTIONS FOR THE ON-CHIP REGULATOR**



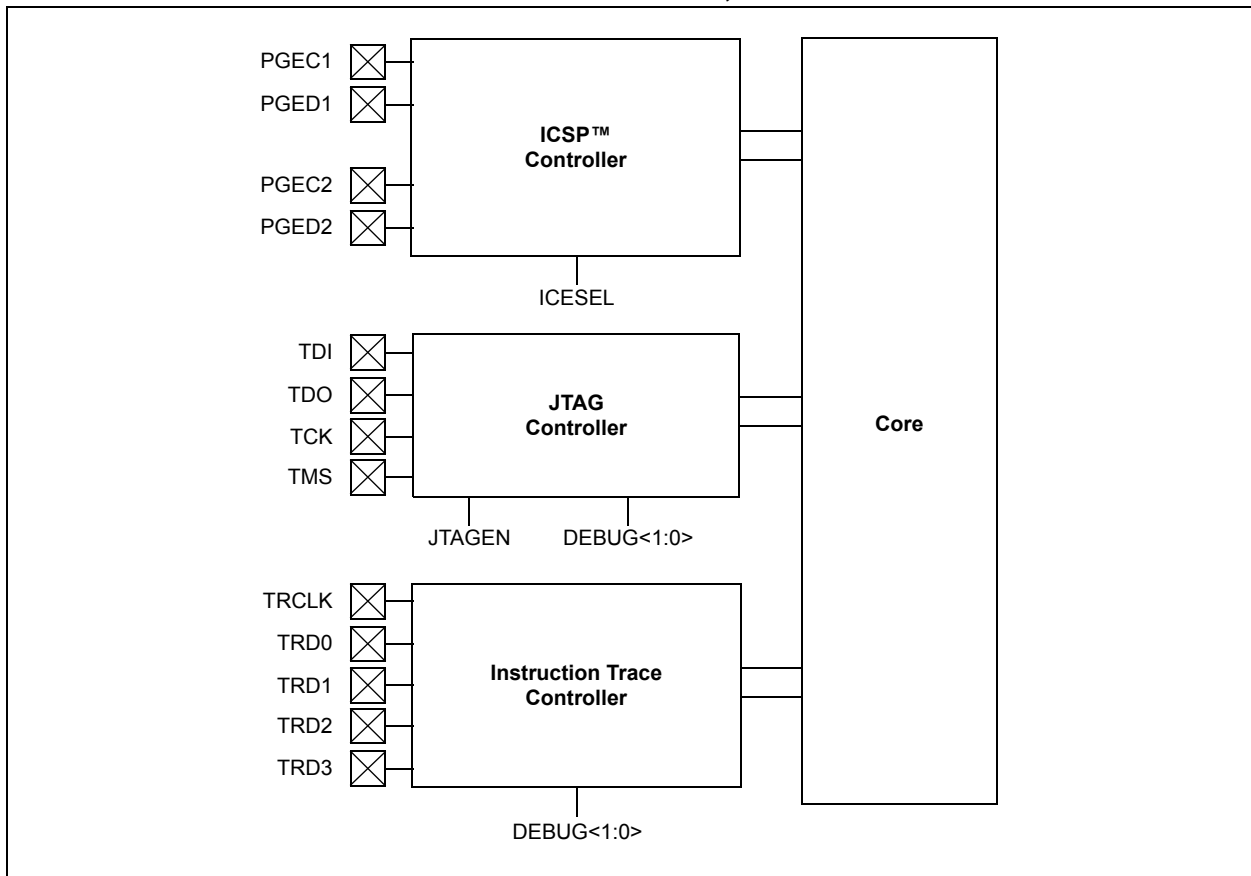
## 28.4 Programming and Diagnostics

PIC32MX5XX/6XX/7XX devices provide a complete range of programming and diagnostic features that can increase the flexibility of any application using them. These features allow system designers to include:

- Simplified field programmability using two-wire In-Circuit Serial Programming™ (ICSP™) interfaces
- Debugging using ICSP
- Programming and debugging capabilities using the EJTAG extension of JTAG
- JTAG boundary scan testing for device and board diagnostics

PIC32MX devices incorporate two programming and diagnostic modules, and a trace controller, that provide a range of functions to the application developer.

**FIGURE 28-3: BLOCK DIAGRAM OF PROGRAMMING, DEBUGGING AND TRACE PORTS**



# PIC32MX5XX/6XX/7XX

## REGISTER 28-6: DDPCON: DEBUG DATA PORT CONTROL REGISTER

r-0	r-0	r-0	r-0	r-0	r-0	r-0	r-0
—	—	—	—	—	—	—	—
bit 31						bit 24	

r-0	r-0	r-0	r-0	r-0	r-0	r-0	r-0
—	—	—	—	—	—	—	—
bit 23						bit 16	

r-0	r-0	r-0	r-0	r-0	r-0	r-0	r-0
—	—	—	—	—	—	—	—
bit 15						bit 8	

r-0	r-0	r-0	r-0	R/W-1	R/W-0	r-0	R/W-0
—	—	—	—	JTAGEN	TROEN	—	TDOEN
bit 7						bit 0	

### Legend:

R = Readable bit      W = Writable bit      P = Programmable bit      r = Reserved bit  
 U = Unimplemented bit      -n = Bit Value at POR: ('0', '1', x = Unknown)

- bit 31-4      **Reserved:** Write '0'; ignore read
- bit 3      **JTAGEN:** JTAG Port Enable bit  
             1 = Enable the JTAG port  
             0 = Disable the JTAG port
- bit 2      **TROEN:** Trace Output Enable bit  
             1 = Enable the trace port  
             0 = Disable the trace port
- bit 1      **Reserved:** Ignore read
- bit 0      **TDOEN:** TDO Enable for 2-Wire JTAG  
             1 = 2-wire JTAG protocol uses TDO  
             0 = 2-wire JTAG protocol does not use TDO

## 29.0 INSTRUCTION SET

The PIC32MX5XX/6XX/7XX family instruction set complies with the MIPS32 Release 2 instruction set architecture. PIC32MX does not support the following features:

- Core extend instructions
- Coprocessor 1 instructions
- Coprocessor 2 instructions

**Note:** Refer to “MIPS32<sup>®</sup> Architecture for Programmers Volume II: The MIPS32<sup>®</sup> Instruction Set” at [www.mips.com](http://www.mips.com) for more information.

# PIC32MX5XX/6XX/7XX

---

NOTES:



## 30.0 DEVELOPMENT SUPPORT

The PIC® microcontrollers and dsPIC® digital signal controllers are supported with a full range of software and hardware development tools:

- Integrated Development Environment
  - MPLAB® IDE Software
- Compilers/Assemblers/Linkers
  - MPLAB C Compiler for Various Device Families
  - HI-TECH C for Various Device Families
  - MPASM™ Assembler
  - MPLINK™ Object Linker/  
MPLIB™ Object Librarian
  - MPLAB Assembler/Linker/Librarian for Various Device Families
- Simulators
  - MPLAB SIM Software Simulator
- Emulators
  - MPLAB REAL ICE™ In-Circuit Emulator
- In-Circuit Debuggers
  - MPLAB ICD 3
  - PICKit™ 3 Debug Express
- Device Programmers
  - PICKit™ 2 Programmer
  - MPLAB PM3 Device Programmer
- Low-Cost Demonstration/Development Boards, Evaluation Kits and Starter Kits

## 30.1 MPLAB Integrated Development Environment Software

The MPLAB IDE software brings an ease of software development previously unseen in the 8/16/32-bit microcontroller market. The MPLAB IDE is a Windows® operating system-based application that contains:

- A single graphical interface to all debugging tools
  - Simulator
  - Programmer (sold separately)
  - In-Circuit Emulator (sold separately)
  - In-Circuit Debugger (sold separately)
- A full-featured editor with color-coded context
- A multiple project manager
- Customizable data windows with direct edit of contents
- High-level source code debugging
- Mouse over variable inspection
- Drag and drop variables from source to watch windows
- Extensive on-line help
- Integration of select third-party tools, such as IAR C Compilers

The MPLAB IDE allows you to:

- Edit your source files (either C or assembly)
- One-touch compile or assemble, and download to emulator and simulator tools (automatically updates all project information)
- Debug using:
  - Source files (C or assembly)
  - Mixed C and assembly
  - Machine code

MPLAB IDE supports multiple debugging tools in a single development paradigm, from the cost-effective simulators, through low-cost in-circuit debuggers, to full-featured emulators. This eliminates the learning curve when upgrading to tools with increased flexibility and power.

# PIC32MX5XX/6XX/7XX

---

## 30.2 MPLAB C Compilers for Various Device Families

The MPLAB C Compiler code development systems are complete ANSI C compilers for Microchip's PIC18, PIC24 and PIC32 families of microcontrollers and the dsPIC30 and dsPIC33 families of digital signal controllers. These compilers provide powerful integration capabilities, superior code optimization and ease of use.

For easy source level debugging, the compilers provide symbol information that is optimized to the MPLAB IDE debugger.

## 30.3 HI-TECH C for Various Device Families

The HI-TECH C Compiler code development systems are complete ANSI C compilers for Microchip's PIC family of microcontrollers and the dsPIC family of digital signal controllers. These compilers provide powerful integration capabilities, omniscient code generation and ease of use.

For easy source level debugging, the compilers provide symbol information that is optimized to the MPLAB IDE debugger.

The compilers include a macro assembler, linker, pre-processor, and one-step driver, and can run on multiple platforms.

## 30.4 MPASM Assembler

The MPASM Assembler is a full-featured, universal macro assembler for PIC10/12/16/18 MCUs.

The MPASM Assembler generates relocatable object files for the MPLINK Object Linker, Intel® standard HEX files, MAP files to detail memory usage and symbol reference, absolute LST files that contain source lines and generated machine code and COFF files for debugging.

The MPASM Assembler features include:

- Integration into MPLAB IDE projects
- User-defined macros to streamline assembly code
- Conditional assembly for multi-purpose source files
- Directives that allow complete control over the assembly process

## 30.5 MPLINK Object Linker/ MPLIB Object Librarian

The MPLINK Object Linker combines relocatable objects created by the MPASM Assembler and the MPLAB C18 C Compiler. It can link relocatable objects from precompiled libraries, using directives from a linker script.

The MPLIB Object Librarian manages the creation and modification of library files of precompiled code. When a routine from a library is called from a source file, only the modules that contain that routine will be linked in with the application. This allows large libraries to be used efficiently in many different applications.

The object linker/library features include:

- Efficient linking of single libraries instead of many smaller files
- Enhanced code maintainability by grouping related modules together
- Flexible creation of libraries with easy module listing, replacement, deletion and extraction

## 30.6 MPLAB Assembler, Linker and Librarian for Various Device Families

MPLAB Assembler produces relocatable machine code from symbolic assembly language for PIC24, PIC32 and dsPIC DSC devices. MPLAB C Compiler uses the assembler to produce its object file. The assembler generates relocatable object files that can then be archived or linked with other relocatable object files and archives to create an executable file. Notable features of the assembler include:

- Support for the entire device instruction set
- Support for fixed-point and floating-point data
- Command line interface
- Rich directive set
- Flexible macro language
- MPLAB IDE compatibility

## 30.7 MPLAB SIM Software Simulator

The MPLAB SIM Software Simulator allows code development in a PC-hosted environment by simulating the PIC<sup>®</sup> MCUs and dsPIC DSCs on an instruction level. On any given instruction, the data areas can be examined or modified and stimuli can be applied from a comprehensive stimulus controller. Registers can be logged to files for further run-time analysis. The trace buffer and logic analyzer display extend the power of the simulator to record and track program execution, actions on I/O, most peripherals and internal registers.

The MPLAB SIM Software Simulator fully supports symbolic debugging using the MPLAB C Compilers, and the MPASM and MPLAB Assemblers. The software simulator offers the flexibility to develop and debug code outside of the hardware laboratory environment, making it an excellent, economical software development tool.

## 30.8 MPLAB REAL ICE In-Circuit Emulator System

MPLAB REAL ICE In-Circuit Emulator System is Microchip's next generation high-speed emulator for Microchip Flash DSC and MCU devices. It debugs and programs PIC<sup>®</sup> Flash MCUs and dsPIC<sup>®</sup> Flash DSCs with the easy-to-use, powerful graphical user interface of the MPLAB Integrated Development Environment (IDE), included with each kit.

The emulator is connected to the design engineer's PC using a high-speed USB 2.0 interface and is connected to the target with either a connector compatible with in-circuit debugger systems (RJ11) or with the new high-speed, noise tolerant, Low-Voltage Differential Signal (LVDS) interconnection (CAT5).

The emulator is field upgradable through future firmware downloads in MPLAB IDE. In upcoming releases of MPLAB IDE, new devices will be supported, and new features will be added. MPLAB REAL ICE offers significant advantages over competitive emulators including low-cost, full-speed emulation, run-time variable watches, trace analysis, complex breakpoints, a ruggedized probe interface and long (up to three meters) interconnection cables.

## 30.9 MPLAB ICD 3 In-Circuit Debugger System

MPLAB ICD 3 In-Circuit Debugger System is Microchip's most cost effective high-speed hardware debugger/programmer for Microchip Flash Digital Signal Controller (DSC) and Microcontroller (MCU) devices. It debugs and programs PIC<sup>®</sup> Flash microcontrollers and dsPIC DSCs with the powerful, yet easy-to-use graphical user interface of MPLAB Integrated Development Environment (IDE).

The MPLAB ICD 3 In-Circuit Debugger probe is connected to the design engineer's PC using a high-speed USB 2.0 interface and is connected to the target with a connector compatible with the MPLAB ICD 2 or MPLAB REAL ICE systems (RJ-11). MPLAB ICD 3 supports all MPLAB ICD 2 headers.

## 30.10 PICkit 3 In-Circuit Debugger/Programmer and PICkit 3 Debug Express

The MPLAB PICkit 3 allows debugging and programming of PIC<sup>®</sup> and dsPIC<sup>®</sup> Flash microcontrollers at a most affordable price point using the powerful graphical user interface of the MPLAB Integrated Development Environment (IDE). The MPLAB PICkit 3 is connected to the design engineer's PC using a full speed USB interface and can be connected to the target via an Microchip debug (RJ-11) connector (compatible with MPLAB ICD 3 and MPLAB REAL ICE). The connector uses two device I/O pins and the reset line to implement In-Circuit Debugging and In-Circuit Serial Programming™.

The PICkit 3 Debug Express include the PICkit 3, demo board and microcontroller, hookup cables and CDROM with user's guide, lessons, tutorial, compiler and MPLAB IDE software.

# PIC32MX5XX/6XX/7XX

---

## 30.11 PICkit 2 Development Programmer/Debugger and PICkit 2 Debug Express

The PICkit™ 2 Development Programmer/Debugger is a low-cost development tool with an easy to use interface for programming and debugging Microchip's Flash families of microcontrollers. The full featured Windows® programming interface supports baseline (PIC10F, PIC12F5xx, PIC16F5xx), midrange (PIC12F6xx, PIC16F), PIC18F, PIC24, dsPIC30, dsPIC33, and PIC32 families of 8-bit, 16-bit, and 32-bit microcontrollers, and many Microchip Serial EEPROM products. With Microchip's powerful MPLAB Integrated Development Environment (IDE) the PICkit™ 2 enables in-circuit debugging on most PIC® microcontrollers. In-Circuit-Debugging runs, halts and single steps the program while the PIC microcontroller is embedded in the application. When halted at a breakpoint, the file registers can be examined and modified.

The PICkit 2 Debug Express include the PICkit 2, demo board and microcontroller, hookup cables and CDRom with user's guide, lessons, tutorial, compiler and MPLAB IDE software.

## 30.12 MPLAB PM3 Device Programmer

The MPLAB PM3 Device Programmer is a universal, CE compliant device programmer with programmable voltage verification at VDDMIN and VDDMAX for maximum reliability. It features a large LCD display (128 x 64) for menus and error messages and a modular, detachable socket assembly to support various package types. The ICSP™ cable assembly is included as a standard item. In Stand-Alone mode, the MPLAB PM3 Device Programmer can read, verify and program PIC devices without a PC connection. It can also set code protection in this mode. The MPLAB PM3 connects to the host PC via an RS-232 or USB cable. The MPLAB PM3 has high-speed communications and optimized algorithms for quick programming of large memory devices and incorporates an MMC card for file storage and data applications.

## 30.13 Demonstration/Development Boards, Evaluation Kits, and Starter Kits

A wide variety of demonstration, development and evaluation boards for various PIC MCUs and dsPIC DSCs allows quick application development on fully functional systems. Most boards include prototyping areas for adding custom circuitry and provide application firmware and source code for examination and modification.

The boards support a variety of features, including LEDs, temperature sensors, switches, speakers, RS-232 interfaces, LCD displays, potentiometers and additional EEPROM memory.

The demonstration and development boards can be used in teaching environments, for prototyping custom circuits and for learning about various microcontroller applications.

In addition to the PICDEM™ and dsPICDEM™ demonstration/development board series of circuits, Microchip has a line of evaluation kits and demonstration software for analog filter design, KEELOQ® security ICs, CAN, IrDA®, PowerSmart battery management, SEEVAL® evaluation system, Sigma-Delta ADC, flow rate sensing, plus many more.

Also available are starter kits that contain everything needed to experience the specified device. This usually includes a single application and debug capability, all on one board.

Check the Microchip web page ([www.microchip.com](http://www.microchip.com)) for the complete list of demonstration, development and evaluation kits.

## 31.0 ELECTRICAL CHARACTERISTICS

This section provides an overview of the PIC32MX5XX/6XX/7XX electrical characteristics. Additional information will be provided in future revisions of this document as it becomes available.

Absolute maximum ratings for the PIC32MX5XX/6XX/7XX devices are listed below. Exposure to these maximum rating conditions for extended periods may affect device reliability. Functional operation of the device at these or any other conditions, above the parameters indicated in the operation listings of this specification, is not implied.

### Absolute Maximum Ratings<sup>(1)</sup>

Ambient temperature under bias .....	-40°C to +85°C
Storage temperature .....	-65°C to +150°C
Voltage on VDD with respect to VSS .....	-0.3V to +4.0V
Voltage on any pin that is not 5V tolerant, with respect to VSS ( <b>Note 3</b> ).....	-0.3V to (VDD + 0.3V)
Voltage on any 5V tolerant pin with respect to VSS when VDD ≥ 2.3V ( <b>Note 3</b> ).....	-0.3V to +5.5V
Voltage on any 5V tolerant pin with respect to VSS when VDD < 2.3V ( <b>Note 3</b> ).....	-0.3V to (VDD + 0.3V)
Voltage on VDDCORE with respect to VSS .....	-0.3V to 2.0V
Maximum current out of VSS pin(s).....	300 mA
Maximum current into VDD pin(s) ( <b>Note 2</b> ).....	300 mA
Maximum output current sunk by any I/O pin.....	25 mA
Maximum output current sourced by any I/O pin .....	25 mA
Maximum current sunk by all ports .....	200 mA
Maximum current sourced by all ports ( <b>Note 2</b> ).....	200 mA

- Note 1:** Stresses above those listed under “**Absolute Maximum Ratings**” may cause permanent damage to the device. This is a stress rating only and functional operation of the device at those or any other conditions, above those indicated in the operation listings of this specification, is not implied. Exposure to maximum rating conditions for extended periods may affect device reliability.
- 2:** Maximum allowable current is a function of device maximum power dissipation (see Table 31-2).
- 3:** See the “**Pin Diagrams**” section for the 5V tolerant pins.

# PIC32MX5XX/6XX/7XX

## 31.1 DC Characteristics

**TABLE 31-1: OPERATING MIPS VS. VOLTAGE**

Characteristic	VDD Range (in Volts)	Temp. Range (in °C)	Max. Frequency
			PIC32MX5XX/6XX/7XX
DC5	2.3-3.6V	-40°C to +85°C	80 MHz

**TABLE 31-2: THERMAL OPERATING CONDITIONS**

Rating	Symbol	Min.	Typical	Max.	Unit
<b>PIC32MX5XX/6XX/7XX</b>					
Operating Junction Temperature Range	TJ	-40	—	+125	°C
Operating Ambient Temperature Range	TA	-40	—	+85	°C
Power Dissipation: Internal Chip Power Dissipation: P <sub>INT</sub> = V <sub>DD</sub> x (I <sub>DD</sub> – S I <sub>OH</sub> ) I/O Pin Power Dissipation: I/O = S ({V <sub>DD</sub> – V <sub>OH</sub> } x I <sub>OH</sub> ) + S (V <sub>OL</sub> x I <sub>OL</sub> )	P <sub>D</sub>	P <sub>INT</sub> + P <sub>I/O</sub>			W
Maximum Allowed Power Dissipation	P <sub>D</sub> MAX	(T <sub>J</sub> – T <sub>A</sub> )/θ <sub>JA</sub>			W

**TABLE 31-3: THERMAL PACKAGING CHARACTERISTICS**

Characteristics	Symbol	Typical	Max.	Unit	Notes
Package Thermal Resistance, 121-Pin XBGA (10x10x1.1 mm)	θ <sub>JA</sub>	40	—	°C/W	1
Package Thermal Resistance, 100-Pin TQFP (14x14x1 mm)	θ <sub>JA</sub>	43	—	°C/W	1
Package Thermal Resistance, 100-Pin TQFP (12x12x1 mm)	θ <sub>JA</sub>	43	—	°C/W	1
Package Thermal Resistance, 64-Pin TQFP (10x10x1 mm)	θ <sub>JA</sub>	47	—	°C/W	1
Package Thermal Resistance, 64-Pin QFN (9x9x0.9 mm)	θ <sub>JA</sub>	28	—	°C/W	1

**Note 1:** Junction to ambient thermal resistance, Theta-JA (θ<sub>JA</sub>) numbers are achieved by package simulations.

**TABLE 31-4: DC TEMPERATURE AND VOLTAGE SPECIFICATIONS**

DC CHARACTERISTICS			Standard Operating Conditions: 2.3V to 3.6V (unless otherwise stated) Operating temperature -40°C ≤ T <sub>A</sub> ≤ +85°C for Industrial				
Param. No.	Symbol	Characteristics	Min.	Typical	Max.	Units	Conditions
<b>Operating Voltage</b>							
DC10	<b>Supply Voltage</b>						
	V <sub>DD</sub>		2.3	—	3.6	V	—
DC12	V <sub>DR</sub>	<b>RAM Data Retention Voltage (Note 1)</b>	1.75	—	—	V	—
DC16	V <sub>POR</sub>	<b>V<sub>DD</sub> Start Voltage</b> to Ensure Internal Power-on Reset Signal	1.75	—	1.95	V	—
DC17	S <sub>VDD</sub>	<b>V<sub>DD</sub> Rise Rate</b> to Ensure Internal Power-on Reset Signal	0.00005	—	0.115	V/μs	—

**Note 1:** This is the limit to which V<sub>DD</sub> can be lowered without losing RAM data.

# PIC32MX5XX/6XX/7XX

**TABLE 31-5: DC CHARACTERISTICS: OPERATING CURRENT (IDD)**

DC CHARACTERISTICS			Standard Operating Conditions: 2.3V to 3.6V (unless otherwise stated) Operating temperature $-40^{\circ}\text{C} \leq T_A \leq +85^{\circ}\text{C}$ for Industrial			
Parameter No.	Typical <sup>(3)</sup>	Max.	Units	Conditions		
<b>Operating Current (IDD)<sup>(1,2)</sup> for PIC32MX575/675/695/775 Family Devices</b>						
DC20	6	9	mA	Code executing from Flash	—	4 MHz
DC20a	4	—	mA	Code executing from SRAM	—	
DC21	37	40	mA	Code executing from Flash	—	25 MHz <b>(Note 4)</b>
DC21a	25	—	mA	Code executing from SRAM	—	
DC22	64	70	mA	Code executing from Flash	—	60 MHz <b>(Note 4)</b>
DC22a	61	—	mA	Code executing from SRAM	—	
DC23	85	98	mA	Code executing from Flash	—	80 MHz
DC23a	85	—	mA	Code executing from SRAM	—	
DC25a	125	150	$\mu\text{A}$	+25°C	3.3V	LPRC (31 kHz) <b>(Note 4)</b>

- Note 1:** A device's IDD supply current is mainly a function of the operating voltage and frequency. Other factors, such as PBCLK (Peripheral Bus Clock) frequency, number of peripheral modules enabled, internal code execution pattern, execution from Program Flash memory vs. SRAM, I/O pin loading and switching rate, oscillator type, as well as temperature, can have an impact on the current consumption.
- 2:** The test conditions for IDD measurements are as follows: Oscillator mode = EC+PLL with OSC1 driven by external square wave from rail-to-rail and PBCLK divisor = 1:8. CPU, Program Flash and SRAM data memory are operational, program Flash memory Wait states = 7, program cache and prefetch are disabled and SRAM data memory Wait states = 1. All peripheral modules are disabled (ON bit = 0). WDT and FSCM are disabled. All I/O pins are configured as inputs and pulled to VSS. MCLR = VDD.
- 3:** Data in "Typical" column is at 3.3V, 25°C at specified operating frequency unless otherwise stated. Parameters are for design guidance only and are not tested.
- 4:** This parameter is characterized, but not tested in manufacturing.

# PIC32MX5XX/6XX/7XX

**TABLE 31-6: DC CHARACTERISTICS: IDLE CURRENT (IDLE)**

DC CHARACTERISTICS			Standard Operating Conditions: 2.3V to 3.6V (unless otherwise stated) Operating temperature $-40^{\circ}\text{C} \leq T_A \leq +85^{\circ}\text{C}$ for Industrial		
Parameter No.	Typical <sup>(2)</sup>	Max.	Units	Conditions	
<b>Idle Current (IDLE): Core Off, Clock On Base Current (Note 1) for PIC32MX575/675/695/775 Family Devices</b>					
DC30	4.5	6.5	mA	4 MHz	
DC31	13	15	mA	25 MHz (Note 3)	
DC32	28	30	mA	60 MHz (Note 3)	
DC33	36	42	mA	80 MHz	
DC34	—	40	$\mu\text{A}$	$-40^{\circ}\text{C}$	LPRC (31 kHz) (Note 3)
DC34a	—	75	$\mu\text{A}$	$+25^{\circ}\text{C}$	
DC34b	—	800	$\mu\text{A}$	$+85^{\circ}\text{C}$	
DC35	35	—	$\mu\text{A}$	$-40^{\circ}\text{C}$	
DC35a	65	—	$\mu\text{A}$	$+25^{\circ}\text{C}$	
DC35b	600	—	$\mu\text{A}$	$+85^{\circ}\text{C}$	
DC36	—	43	$\mu\text{A}$	$-40^{\circ}\text{C}$	
DC36a	—	106	$\mu\text{A}$	$+25^{\circ}\text{C}$	
DC36b	—	800	$\mu\text{A}$	$+85^{\circ}\text{C}$	

- Note 1:** The test conditions for base IDLE current measurements are as follows: System clock is enabled and PBCLK divisor = 1:8. CPU in Idle mode (CPU core Halted). Only digital peripheral modules are enabled (ON bit = 1) and being clocked. WDT and FSCM are disabled. All I/O pins are configured as inputs and pulled to V<sub>SS</sub>. MCLR = V<sub>DD</sub>.
- 2:** Data in “Typical” column is at 3.3V, 25°C unless otherwise stated. Parameters are for design guidance only and are not tested.
- 3:** This parameter is characterized, but not tested in manufacturing.



# PIC32MX5XX/6XX/7XX

**TABLE 31-7: DC CHARACTERISTICS: POWER-DOWN CURRENT (IPD)**

DC CHARACTERISTICS			Standard Operating Conditions: 2.3V to 3.6V (unless otherwise stated) Operating temperature $-40^{\circ}\text{C} \leq T_A \leq +85^{\circ}\text{C}$ for Industrial		
Param. No.	Typical <sup>(2)</sup>	Max.	Units	Conditions	
<b>Power-Down Current (IPD) (Note 1) for PIC32MX575/675/695/775 Family Devices</b>					
DC40	10	40	$\mu\text{A}$	$-40^{\circ}\text{C}$	2.3V Base Power-Down Current ( <b>Note 6</b> )
DC40a	36	100	$\mu\text{A}$	$+25^{\circ}\text{C}$	
DC40b	400	720	$\mu\text{A}$	$+85^{\circ}\text{C}$	
DC40c	41	120	$\mu\text{A}$	$+25^{\circ}\text{C}$	3.3V Base Power-Down Current
DC40d	22	80	$\mu\text{A}$	$-40^{\circ}\text{C}$	3.6V Base Power-Down Current
DC40e	42	120	$\mu\text{A}$	$+25^{\circ}\text{C}$	
DC40g	315	400	$\mu\text{A}$	$+70^{\circ}\text{C}$	
DC40f	410	800	$\mu\text{A}$	$+85^{\circ}\text{C}$	
<b>Module Differential Current for PIC32MX575/675/695/775 Family Devices</b>					
DC41	—	10	$\mu\text{A}$	2.3V	Watchdog Timer Current: $\Delta I_{\text{WDT}}$ ( <b>Notes 3,6</b> )
DC41a	5	—	$\mu\text{A}$	3.3V	Watchdog Timer Current: $\Delta I_{\text{WDT}}$ ( <b>Note 3</b> )
DC41b	—	20	$\mu\text{A}$	3.6V	Watchdog Timer Current: $\Delta I_{\text{WDT}}$ ( <b>Note 3</b> )
DC42	—	40	$\mu\text{A}$	2.3V	RTCC + Timer1 w/32 kHz Crystal: $\Delta I_{\text{RTCC}}$ ( <b>Notes 3,6</b> )
DC42a	23	—	$\mu\text{A}$	3.3V	RTCC + Timer1 w/32 kHz Crystal: $\Delta I_{\text{RTCC}}$ ( <b>Note 3</b> )
DC42b	—	50	$\mu\text{A}$	3.6V	RTCC + Timer1 w/32 kHz Crystal: $\Delta I_{\text{RTCC}}$ ( <b>Note 3</b> )
DC43	—	1300	$\mu\text{A}$	2.5V	ADC: $\Delta I_{\text{ADC}}$ ( <b>Notes 3,4,6</b> )
DC43a	1100	—	$\mu\text{A}$	3.3V	ADC: $\Delta I_{\text{ADC}}$ ( <b>Notes 3,4</b> )
DC43b	—	1300	$\mu\text{A}$	3.6V	ADC: $\Delta I_{\text{ADC}}$ ( <b>Notes 3,4</b> )

- Note 1:** Base IPD is measured with all digital peripheral modules and being clocked, CPU clock is disabled. All I/Os are configured as inputs and pulled low. WDT and FSCM are disabled.
- Note 2:** Data in the “Typical” column is at 3.3V, 25°C unless otherwise stated. Parameters are for design guidance only and are not tested.
- Note 3:** The  $\Delta$  current is the additional current consumed when the module is enabled. This current should be added to the base IPD current.
- Note 4:** Test conditions for ADC module differential current are as follows: Internal ADC RC oscillator enabled.
- Note 5:** Data is characterized at  $+70^{\circ}\text{C}$  and not tested. Parameter is for design guidance only.
- Note 6:** This parameter is characterized, but not tested in manufacturing.

# PIC32MX5XX/6XX/7XX

**TABLE 31-8: DC CHARACTERISTICS: I/O PIN INPUT SPECIFICATIONS**

DC CHARACTERISTICS			Standard Operating Conditions: 2.3V to 3.6V (unless otherwise stated) Operating temperature $-40^{\circ}\text{C} \leq T_A \leq +85^{\circ}\text{C}$ for Industrial				
Param. No.	Symbol	Characteristics	Min.	Typical <sup>(1)</sup>	Max.	Units	Conditions
DI10 DI15 DI16 DI17 DI18 DI19	V <sub>IL</sub>	<b>Input Low Voltage</b>					
		I/O Pins: with TTL Buffer	V <sub>SS</sub>	—	0.15 V <sub>DD</sub>	V	(Note 4)
		with Schmitt Trigger Buffer	V <sub>SS</sub>	—	0.2 V <sub>DD</sub>	V	(Note 4)
		$\overline{\text{MCLR}}^{(2)}$	V <sub>SS</sub>	—	0.2 V <sub>DD</sub>	V	(Note 4)
		OSC1 (XT mode)	V <sub>SS</sub>	—	0.2 V <sub>DD</sub>	V	(Note 4)
		OSC1 (HS mode)	V <sub>SS</sub>	—	0.2 V <sub>DD</sub>	V	(Note 4)
		SDAx, SCLx	V <sub>SS</sub>	—	0.3 V <sub>DD</sub>	V	SMBus disabled (Note 4)
SDAx, SCLx	V <sub>SS</sub>	—	0.8	V	SMBus enabled (Note 4)		
DI20 DI25 DI26 DI27 DI28 DI29	V <sub>IH</sub>	<b>Input High Voltage</b>					
		I/O Pins: with Analog Functions	0.8 V <sub>DD</sub>	—	V <sub>DD</sub>	V	(Note 4)
		Digital Only	0.8 V <sub>DD</sub>	—		V	(Note 4)
		with TTL Buffer	0.25 V <sub>DD</sub> + 0.8V	—	5.5	V	(Note 4)
		with Schmitt Trigger Buffer	0.8 V <sub>DD</sub>	—	5.5	V	(Note 4)
		$\overline{\text{MCLR}}^{(2)}$	0.8 V <sub>DD</sub>	—	V <sub>DD</sub>	V	(Note 4)
		OSC1 (XT mode)	0.7 V <sub>DD</sub>	—	V <sub>DD</sub>	V	(Note 4)
		OSC1 (HS mode)	0.7 V <sub>DD</sub>	—	V <sub>DD</sub>	V	(Note 4)
		SDAx, SCLx	0.7 V <sub>DD</sub>	—	5.5	V	SMBus disabled (Note 4)
		SDAx, SCLx	2.1	—	5.5	V	SMBus enabled, 2.3V ≤ V <sub>PIN</sub> ≤ 5.5 (Note 4)
DI30	IC <sub>NPU</sub>	<b>CNxx Pull up Current</b>	50	250	400	μA	V <sub>DD</sub> = 3.3V, V <sub>PIN</sub> = V <sub>SS</sub>
DI50 DI51 DI55 DI56	I <sub>IL</sub>	<b>Input Leakage Current (Note 3)</b>					
		I/O Ports	—	—	±1	μA	V <sub>SS</sub> ≤ V <sub>PIN</sub> ≤ V <sub>DD</sub> , Pin at high-impedance
		Analog Input Pins	—	—	±1	μA	V <sub>SS</sub> ≤ V <sub>PIN</sub> ≤ V <sub>DD</sub> , Pin at high-impedance
		$\overline{\text{MCLR}}^{(2)}$	—	—	±1	μA	V <sub>SS</sub> ≤ V <sub>PIN</sub> ≤ V <sub>DD</sub>
		OSC1	—	—	±1	μA	V <sub>SS</sub> ≤ V <sub>PIN</sub> ≤ V <sub>DD</sub> , XT and HS modes

**Note 1:** Data in "Typical" column is at 3.3V, 25°C unless otherwise stated. Parameters are for design guidance only and are not tested.

**2:** The leakage current on the  $\overline{\text{MCLR}}$  pin is strongly dependent on the applied voltage level. The specified levels represent normal operating conditions. Higher leakage current may be measured at different input voltages.

**3:** Negative current is defined as current sourced by the pin.

**4:** This parameter is characterized, but not tested in manufacturing.

# PIC32MX5XX/6XX/7XX

**TABLE 31-9: DC CHARACTERISTICS: I/O PIN OUTPUT SPECIFICATIONS**

DC CHARACTERISTICS			Standard Operating Conditions: 2.3V to 3.6V (unless otherwise stated) Operating temperature $-40^{\circ}\text{C} \leq T_A \leq +85^{\circ}\text{C}$ for Industrial				
Param. No.	Symbol	Characteristics	Min.	Typical	Max.	Units	Conditions
DO10	VOL	<b>Output Low Voltage</b> I/O Ports	—	—	0.4	V	IOL = 7 mA, VDD = 3.6V
			—	—	0.4	V	IOL = 6 mA, VDD = 2.3V
DO16		OSC2/CLKO	—	—	0.4	V	IOL = 3.5 mA, VDD = 3.6V
			—	—	0.4	V	IOL = 2.5 mA, VDD = 2.3V
DO20	VOH	<b>Output High Voltage</b> I/O Ports	2.4	—	—	V	IOH = -12 mA, VDD = 3.6V
			1.4	—	—	V	IOH = -12 mA, VDD = 2.3V
DO26		OSC2/CLKO	2.4	—	—	V	IOH = -12 mA, VDD = 3.6V
			1.4	—	—	V	IOH = -12 mA, VDD = 2.3V

**TABLE 31-10: DC CHARACTERISTICS: PROGRAM MEMORY<sup>(3)</sup>**

DC CHARACTERISTICS			Standard Operating Conditions: 2.3V to 3.6V (unless otherwise stated) Operating temperature $-40^{\circ}\text{C} \leq T_A \leq +85^{\circ}\text{C}$ for Industrial Programming temperature $0^{\circ}\text{C} \leq T_A \leq +70^{\circ}\text{C}$ (25°C recommended)				
Param. No.	Symbol	Characteristics	Min.	Typical <sup>(1)</sup>	Max.	Units	Conditions
<b>Program Flash Memory</b>							
D130	EP	Cell Endurance	1000	—	—	E/W	$-40^{\circ}\text{C}$ to $+85^{\circ}\text{C}$
D131	VPR	VDD for Read	VMIN	—	3.6	V	VMIN = Minimum operating voltage
D132	VPEW	VDD for Erase or Write	3.0	—	3.6	V	$0^{\circ}\text{C}$ to $+40^{\circ}\text{C}$
D134	TRETD	Characteristic Retention	20	—	—	Year	Provided no other specifications are violated
D135	IDDP	Supply Current during Programming	—	10	—	mA	$0^{\circ}\text{C}$ to $+40^{\circ}\text{C}$
D136	TWW	Word Write Cycle Time	20	—	40	$\mu\text{s}$	$0^{\circ}\text{C}$ to $+40^{\circ}\text{C}$
	TRW	Row Write Cycle Time	3	4.5	—	ms	$0^{\circ}\text{C}$ to $+40^{\circ}\text{C}$
D137	TPE	Page Erase Cycle Time	20	—	—	ms	$0^{\circ}\text{C}$ to $+40^{\circ}\text{C}$
	TCE	Chip Erase Cycle Time	80	—	—	ms	$0^{\circ}\text{C}$ to $+40^{\circ}\text{C}$

**Note 1:** Data in “Typical” column is at 3.3V, 25°C unless otherwise stated.

**2:** The minimum SYSCLK for row programming is 4 MHz. Care should be taken to minimize bus activities during row programming, such as suspending any memory-to-memory DMA operations. If heavy bus loads are expected, selecting Bus Matrix Arbitration mode 2 (rotating priority) may be necessary. The default Arbitration mode is mode 1 (CPU has lowest priority).

**3:** Refer to the “PIC32MX Flash Programming Specification” (DS61145) for operating conditions during programming and erase cycles.

# PIC32MX5XX/6XX/7XX

**TABLE 31-11: PROGRAM FLASH MEMORY WAIT STATE CHARACTERISTICS**

DC CHARACTERISTICS		Standard Operating Conditions: 2.3V to 3.6V (unless otherwise stated) Operating temperature $-40^{\circ}\text{C} \leq T_A \leq +85^{\circ}\text{C}$ for Industrial		
Required Flash Wait States	SYSCLK	Units	Comments	
0 Wait State	0 to 30	MHz	—	
1 Wait State	31 to 60			
2 Wait States	61 to 80			

**TABLE 31-12: COMPARATOR SPECIFICATIONS**

DC CHARACTERISTICS			Standard Operating Conditions: 2.3V to 3.6V (unless otherwise stated) Operating temperature $-40^{\circ}\text{C} \leq T_A \leq +85^{\circ}\text{C}$ for Industrial				
Param. No.	Symbol	Characteristics	Min.	Typical	Max.	Units	Comments
D300	V <sub>IOFF</sub>	Input Offset Voltage	—	±7.5	±25	mV	AVDD = VDD, AVSS = VSS
D301	V <sub>ICM</sub>	Input Common Mode Voltage	0	—	VDD	V	AVDD = VDD, AVSS = VSS <b>(Note 2)</b>
D302	CMRR	Common Mode Rejection Ratio	55	—	—	dB	Max V <sub>ICM</sub> = (VDD - 1)V <b>(Note 2)</b>
D303	T <sub>RESP</sub>	Response Time	—	150	400	ns	AVDD = VDD, AVSS = VSS <b>(Notes 1,2)</b>
D304	ON2OV	Comparator Enabled to Output Valid	—	—	10	μs	Comparator module is configured before setting the comparator ON bit. <b>(Note 2)</b>
D305	IVREF	Internal Voltage Reference	1.14	1.2	1.26	V	—

**Note 1:** Response time measured with one comparator input at  $(V_{DD} - 1.5)/2$ , while the other input transitions from VSS to VDD.

**2:** These parameters are characterized but not tested.

# PIC32MX5XX/6XX/7XX

**TABLE 31-13: VOLTAGE REFERENCE SPECIFICATIONS**

DC CHARACTERISTICS			Standard Operating Conditions: 2.3V to 3.6V (unless otherwise stated) Operating temperature $-40^{\circ}\text{C} \leq T_A \leq +85^{\circ}\text{C}$ for Industrial				
Param. No.	Symbol	Characteristics	Min.	Typical	Max.	Units	Comments
D310	VRES	Resolution	VDD/24	—	VDD/32	LSb	—
D311	VRAA	Absolute Accuracy	—	—	1/2	LSb	—
D312	TSET	Settling Time <sup>(1)</sup>	—	—	10	$\mu\text{s}$	—
D313	VIREF	Internal Voltage Reference	—	0.6	—	V	—

**Note 1:** Settling time measured while CVRR = 1 and CVR<3:0> transitions from '0000' to '1111'. This parameter is characterized, but not tested in manufacturing.

**TABLE 31-14: INTERNAL VOLTAGE REGULATOR SPECIFICATIONS**

DC CHARACTERISTICS			Standard Operating Conditions: 2.3V to 3.6V (unless otherwise stated) Operating temperature $-40^{\circ}\text{C} \leq T_A \leq +85^{\circ}\text{C}$ for Industrial				
Param. No.	Symbol	Characteristics	Min.	Typical	Max.	Units	Comments
D320	VDDCORE	Regulator Output Voltage	1.62	1.80	1.98	V	—
D321	CEFC	External Filter Capacitor Value	8	10	—	$\mu\text{F}$	Capacitor must be low series resistance (1 ohm)
D322	TPWRT	Power-up Timer Period	—	64	—	ms	—

# PIC32MX5XX/6XX/7XX

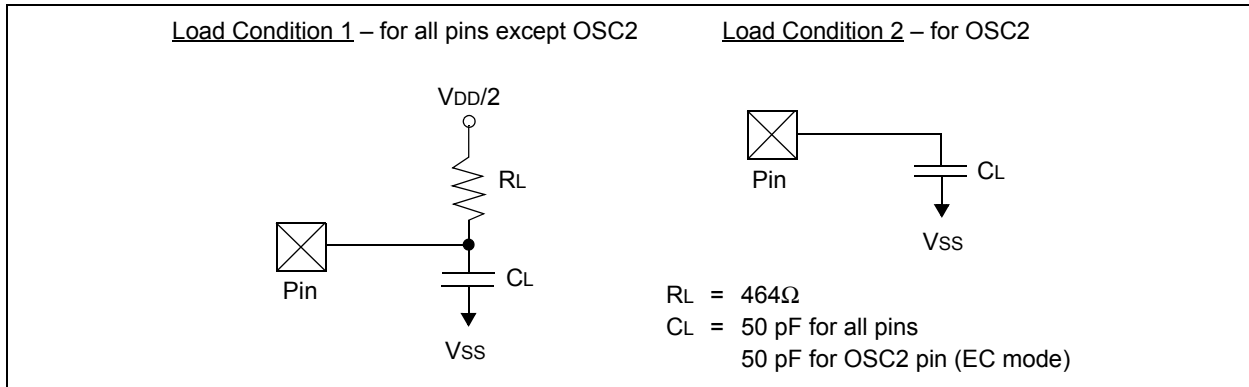
## 31.2 AC Characteristics and Timing Parameters

The information contained in this section defines PIC32MX5XX/6XX/7XX AC characteristics and timing parameters.

**TABLE 31-15: AC CHARACTERISTICS**

<b>AC CHARACTERISTICS</b>	<b>Standard Operating Conditions: 2.3V to 3.6V (unless otherwise stated)</b> Operating temperature $-40^{\circ}\text{C} \leq T_A \leq +85^{\circ}\text{C}$ for Industrial Operating voltage $V_{DD}$ range.
---------------------------	---

**FIGURE 31-1: LOAD CONDITIONS FOR DEVICE TIMING SPECIFICATIONS**

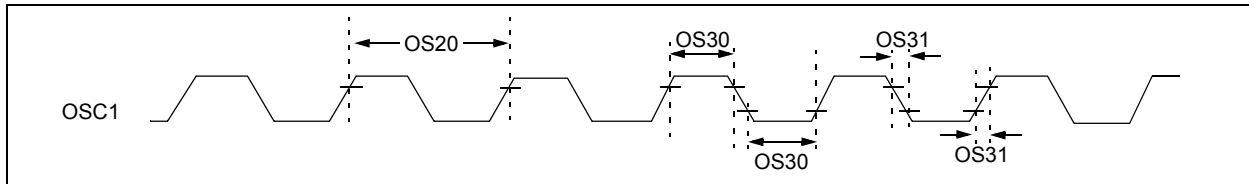


**TABLE 31-16: CAPACITIVE LOADING REQUIREMENTS ON OUTPUT PINS**

<b>AC CHARACTERISTICS</b>			<b>Standard Operating Conditions: 2.3V to 3.6V (unless otherwise stated)</b> Operating temperature $-40^{\circ}\text{C} \leq T_A \leq +85^{\circ}\text{C}$ for Industrial				
Param. No.	Symbol	Characteristics	Min.	Typical <sup>(1)</sup>	Max.	Units	Conditions
DO56	CIO	All I/O pins and OSC2	—	—	50	pF	EC mode
DO58	CB	SCLx, SDAx	—	—	400	pF	In I <sup>2</sup> C™ mode

**Note 1:** Data in “Typical” column is at 3.3V, 25°C unless otherwise stated. Parameters are for design guidance only and are not tested.

**FIGURE 31-2: EXTERNAL CLOCK TIMING**



**TABLE 31-17: EXTERNAL CLOCK TIMING REQUIREMENTS**

AC CHARACTERISTICS			Standard Operating Conditions: 2.3V to 3.6V (unless otherwise stated) Operating temperature $-40^{\circ}\text{C} \leq T_A \leq +85^{\circ}\text{C}$ for Industrial					
Param. No.	Symbol	Characteristics	Min.	Typical <sup>(1)</sup>	Max.	Units	Conditions	
OS10	Fosc	External CLKI Frequency (External clocks allowed only in EC and ECPLL modes)	DC	—	50	MHz	EC ( <b>Note 4</b> ) ECPLL ( <b>Note 3</b> )	
			4	—	50	MHz		
OS11			Oscillator Crystal Frequency	3	—	10	MHz	XT ( <b>Note 4</b> )
OS12				4	—	10	MHz	XTPLL ( <b>Notes 3,4</b> )
OS13				10	—	25	MHz	HS ( <b>Note 5</b> )
OS14				10	—	25	MHz	HSPLL ( <b>Notes 3,4</b> )
OS15	32	32.768		100	kHz	Sosc ( <b>Note 4</b> )		
OS20	Tosc	Tosc = 1/Fosc = Tcy ( <b>Note 2</b> )	—	—	—	—	See parameter OS10 for Fosc value	
OS30	TosL, TosH	External Clock In (OSC1) High or Low Time	0.45 x Tosc	—	—	ns	EC ( <b>Note 4</b> )	
OS31	TosR, TosF	External Clock In (OSC1) Rise or Fall Time	—	—	0.05 x Tosc	ns	EC ( <b>Note 4</b> )	
OS40	TOST	Oscillator Start-up Timer Period (Only applies to HS, HSPLL, XT, XTPLL and Sosc Clock Oscillator modes)	—	1024	—	Tosc	( <b>Note 4</b> )	
OS41	TFSCM	Primary Clock Fail Safe Time-out Period	—	2	—	ms	( <b>Note 4</b> )	
OS42	GM	External Oscillator Transconductance	—	12	—	mAV	VDD = 3.3V, TA = +25°C ( <b>Note 4</b> )	

**Note 1:** Data in “Typical” column is at 3.3V, 25°C unless otherwise stated. Parameters are characterized but are not tested.

- 2:** Instruction cycle period (Tcy) equals the input oscillator time base period. All specified values are based on characterization data for that particular oscillator type under standard operating conditions with the device executing code. Exceeding these specified limits may result in an unstable oscillator operation and/or higher than expected current consumption. All devices are tested to operate at “min.” values with an external clock applied to the OSC1/CLKI pin.
- 3:** PLL input requirements:  $4\text{ MHz} \leq F_{\text{PLLIN}} \leq 5\text{ MHz}$  (use PLL prescaler to reduce Fosc). This parameter is characterized, but tested at 10 MHz only at manufacturing.
- 4:** This parameter is characterized, but not tested in manufacturing.

# PIC32MX5XX/6XX/7XX

**TABLE 31-18: PLL CLOCK TIMING SPECIFICATIONS (VDD = 2.3V TO 3.6V)**

AC CHARACTERISTICS		Standard Operating Conditions: 2.3V to 3.6V (unless otherwise stated) Operating temperature $-40^{\circ}\text{C} \leq T_A \leq +85^{\circ}\text{C}$ for Industrial					
Param. No.	Symbol	Characteristics <sup>(1)</sup>	Min.	Typical <sup>(2)</sup>	Max.	Units	Conditions
OS50	FPLLI	PLL Voltage Controlled Oscillator (VCO) Input Frequency Range	4	—	5	MHz	ECPLL, HSPLL, XTPLL, FRCPLL modes
OS51	FSYS	On-Chip VCO System Frequency	60	—	120	MHz	—
OS52	TLOCK	PLL Start-up Time (Lock Time)	—	—	2	ms	—
OS53	DCLK	CLKO Stability (Period Jitter or Cumulative)	-0.25	—	+0.25	%	Measured over 100 ms period

**Note 1:** These parameters are characterized, but not tested in manufacturing.

**2:** Data in “Typical” column is at 3.3V, 25°C unless otherwise stated. Parameters are for design guidance only and are not tested.

**TABLE 31-19: INTERNAL FRC ACCURACY**

AC CHARACTERISTICS		Standard Operating Conditions: 2.3V to 3.6V (unless otherwise stated) Operating temperature $-40^{\circ}\text{C} \leq T_A \leq +85^{\circ}\text{C}$ for industrial					
Param. No.	Characteristics	Min.	Typical	Max.	Units	Conditions	
<b>Internal FRC Accuracy @ 8.00 MHz (Note 1)</b>							
F20	FRC	-2	—	+2	%	—	

**Note 1:** Frequency calibrated at 25°C and 3.3V. The TUN bits can be used to compensate for temperature drift.

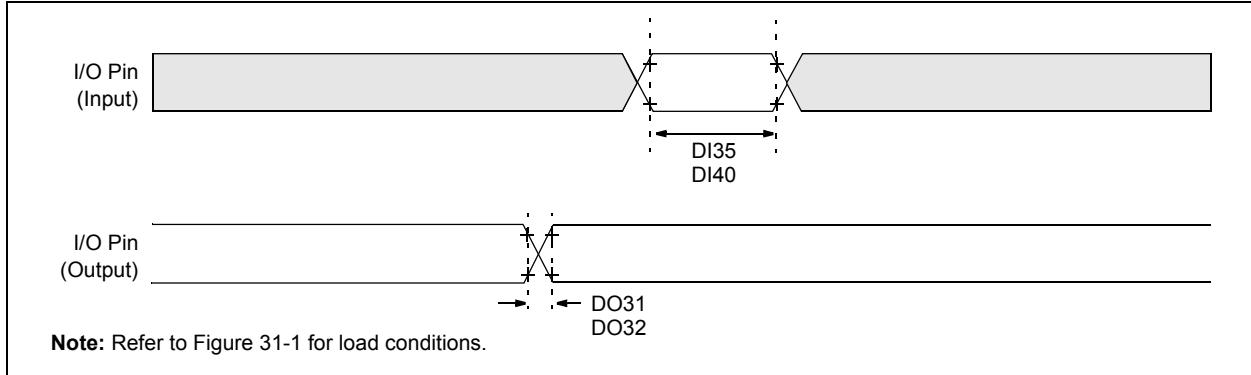
**TABLE 31-20: INTERNAL RC ACCURACY**

AC CHARACTERISTICS		Standard Operating Conditions: 2.3V to 3.6V (unless otherwise stated) Operating temperature $-40^{\circ}\text{C} \leq T_A \leq +85^{\circ}\text{C}$ for Industrial					
Param. No.	Characteristics	Min.	Typical	Max.	Units	Conditions	
<b>LPRC @ 31.25 kHz (Note 1)</b>							
F21	LPRC	-15	—	+15	%	—	

**Note 1:** Change of LPRC frequency as VDD changes.



**FIGURE 31-3: I/O TIMING CHARACTERISTICS**



**TABLE 31-21: I/O TIMING REQUIREMENTS**

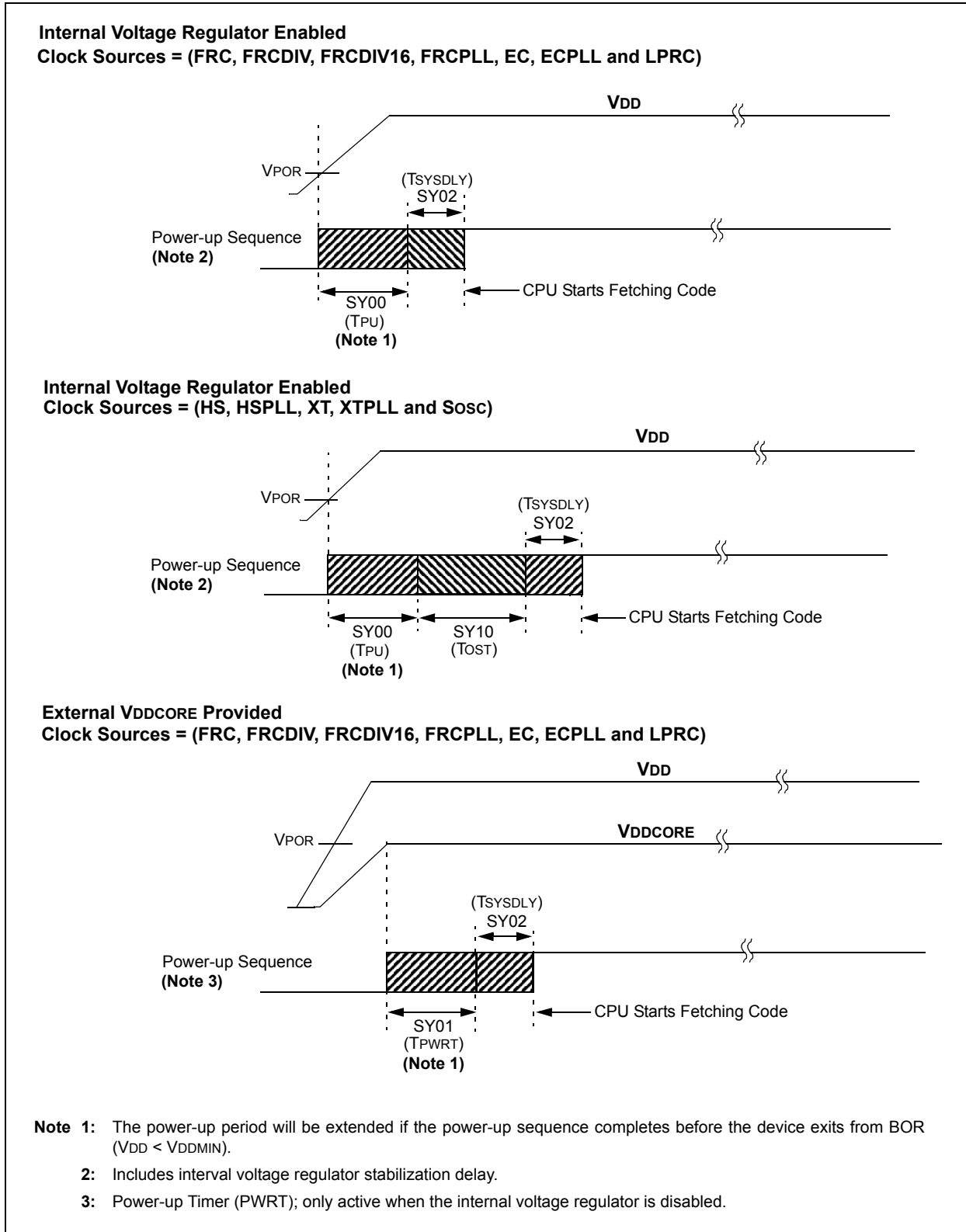
AC CHARACTERISTICS		Standard Operating Conditions: 2.3V to 3.6V (unless otherwise stated) Operating temperature $-40^{\circ}\text{C} \leq T_A \leq +85^{\circ}\text{C}$ for Industrial					
Param. No.	Symbol	Characteristics <sup>(2)</sup>	Min.	Typical <sup>(1)</sup>	Max.	Units	Conditions
DO31	TioR	Port Output Rise Time	—	5	15	ns	$V_{DD} < 2.5\text{V}$
			—	5	10	ns	$V_{DD} > 2.5\text{V}$
DO32	TioF	Port Output Fall Time	—	5	15	ns	$V_{DD} < 2.5\text{V}$
			—	5	10	ns	$V_{DD} > 2.5\text{V}$
DI35	TINP	INTx Pin High or Low Time	10	—	—	ns	—
DI40	TRBP	CNx High or Low Time (input)	2	—	—	TSYSCLK	—

**Note 1:** Data in “Typical” column is at 3.3V, 25°C unless otherwise stated.

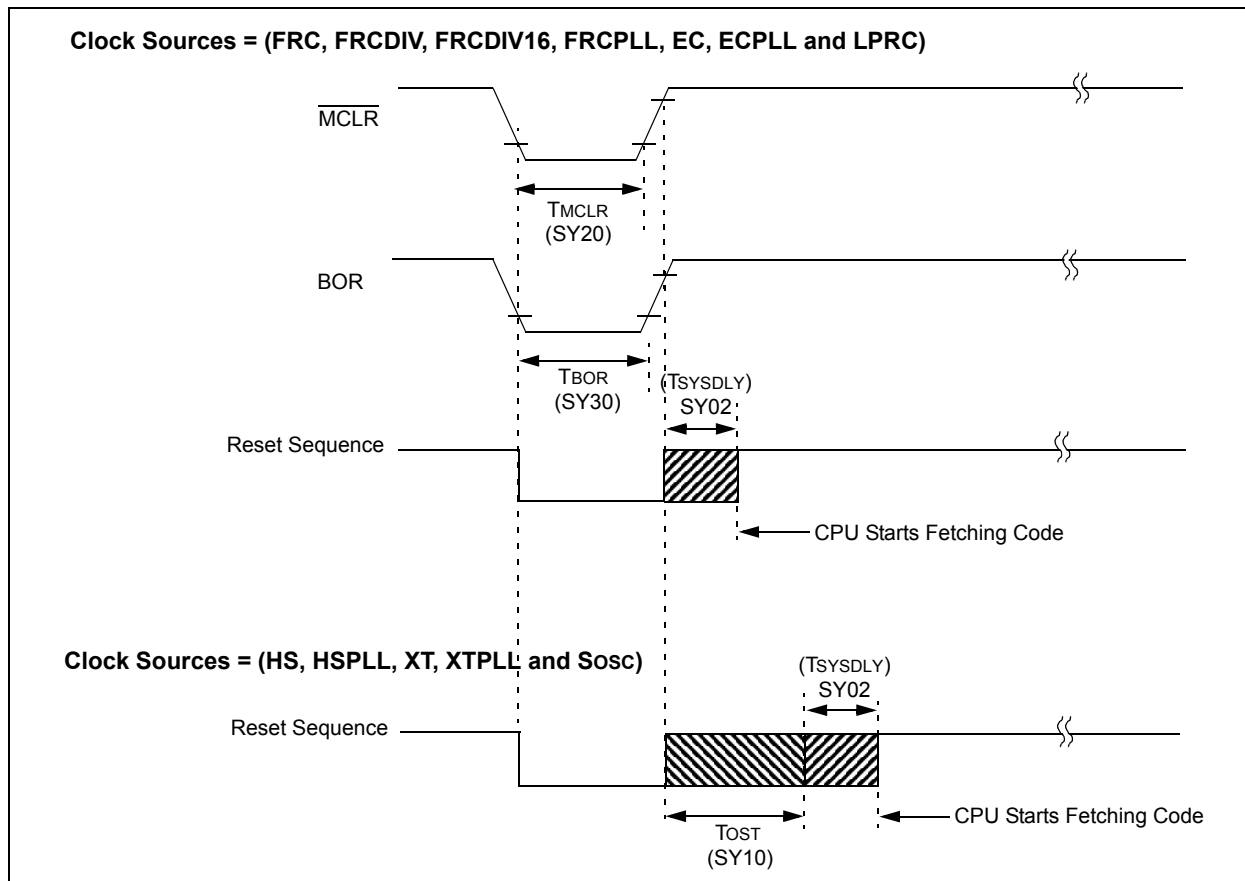
**2:** This parameter is characterized, but not tested in manufacturing.

# PIC32MX5XX/6XX/7XX

**FIGURE 31-4: POWER-ON RESET TIMING CHARACTERISTICS**



**FIGURE 31-5: EXTERNAL RESET TIMING CHARACTERISTICS**



**TABLE 31-22: RESETS TIMING**

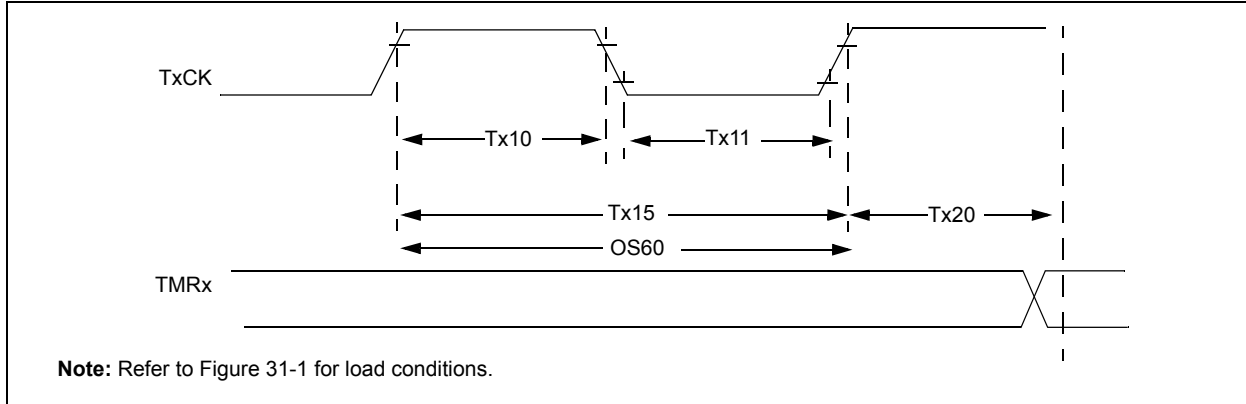
AC CHARACTERISTICS			Standard Operating Conditions: 2.3V to 3.6V (unless otherwise stated) Operating temperature $-40^{\circ}\text{C} \leq T_A \leq +85^{\circ}\text{C}$ for Industrial				
Param. No.	Symbol	Characteristics <sup>(1)</sup>	Min.	Typical <sup>(2)</sup>	Max.	Units	Conditions
SY00	TPU	Power-up Period Internal Voltage Regulator Enabled	—	400	600	$\mu\text{s}$	$-40^{\circ}\text{C}$ to $+85^{\circ}\text{C}$
SY01	TPWRT	Power-up Period External VDDCORE Applied (Power-up timer active)	48	64	80	ms	$-40^{\circ}\text{C}$ to $+85^{\circ}\text{C}$
SY02	TSYSDLY	System Delay Period: Time Required to Reload Device Configuration Fuses plus SYSCLK Delay before First instruction is Fetched.	—	$1\ \mu\text{s} +$ 8 SYSCLK cycles	—	—	$-40^{\circ}\text{C}$ to $+85^{\circ}\text{C}$
SY20	TMCLR	MCLR Pulse Width (low)	—	2	—	$\mu\text{s}$	$-40^{\circ}\text{C}$ to $+85^{\circ}\text{C}$
SY30	TBOR	BOR Pulse Width (low)	—	1	—	$\mu\text{s}$	$-40^{\circ}\text{C}$ to $+85^{\circ}\text{C}$

**Note 1:** These parameters are characterized, but not tested in manufacturing.

**Note 2:** Data in "Typ" column is at 3.3V, 25°C unless otherwise stated. Characterized by design but not tested.

# PIC32MX5XX/6XX/7XX

**FIGURE 31-6: TIMER1, 2, 3, 4, 5 EXTERNAL CLOCK TIMING CHARACTERISTICS**



**TABLE 31-23: TIMER1 EXTERNAL CLOCK TIMING REQUIREMENTS<sup>(1)</sup>**

AC CHARACTERISTICS			Standard Operating Conditions: 2.3V to 3.6V (unless otherwise stated) Operating temperature $-40^{\circ}\text{C} \leq T_A \leq +85^{\circ}\text{C}$ for Industrial					
Param. No.	Symbol	Characteristics <sup>(2)</sup>	Min.	Typical	Max.	Units	Conditions	
TA10	TtxH	TxCK High Time	Synchronous, with prescaler	$[(12.5 \text{ ns or } 1 \text{ TPB})/N] + 25 \text{ ns}$	—	—	ns	Must also meet parameter TA15
		Asynchronous, with prescaler	10	—	—	ns	—	
TA11	TtxL	TxCK Low Time	Synchronous, with prescaler	$[(12.5 \text{ ns or } 1 \text{ TPB})/N] + 25 \text{ ns}$	—	—	ns	Must also meet parameter TA15
		Asynchronous, with prescaler	10	—	—	ns	—	
TA15	TtxP	TxCK Input Period	Synchronous, with prescaler	$[(\text{Greater of } 25 \text{ ns or } 2 \text{ TPB})/N] + 30 \text{ ns}$	—	—	ns	$V_{DD} > 2.7\text{V}$
			Asynchronous, with prescaler	20	—	—	ns	$V_{DD} > 2.7\text{V}$ <b>(Note 3)</b>
		Asynchronous, with prescaler	50	—	—	ns	$V_{DD} < 2.7\text{V}$ <b>(Note 3)</b>	
			—	—	—	—	—	—
OS60	Ft1	SOSC1/T1CK Oscillator Input Frequency Range (oscillator enabled by setting TCS bit (T1CON<1>))	32	—	100	kHz	—	
TA20	TCKEXTMRL	Delay from External TxCK Clock Edge to Timer Increment	—	—	1	TPB	—	

**Note 1:** Timer1 is a Type A.

**Note 2:** This parameter is characterized, but not tested in manufacturing.

**Note 3:** N = Prescale Value (1, 8, 64, 256).

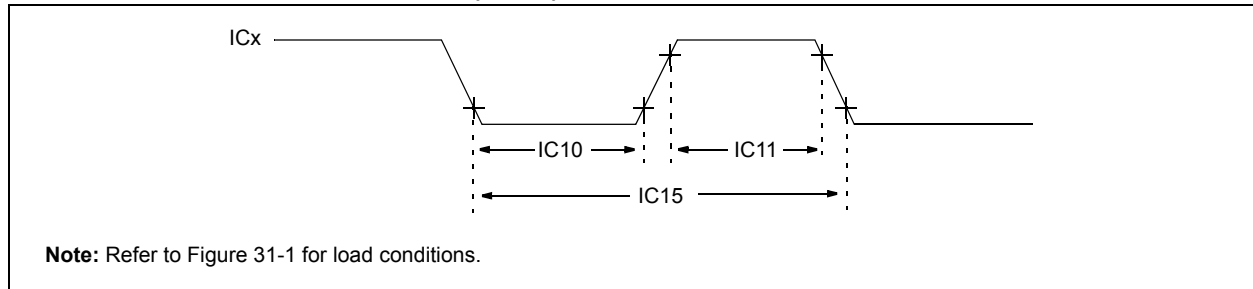
# PIC32MX5XX/6XX/7XX

**TABLE 31-24: TIMER2, 3, 4, 5 EXTERNAL CLOCK TIMING REQUIREMENTS**

AC CHARACTERISTICS		Standard Operating Conditions: 2.3V to 3.6V (unless otherwise stated) Operating temperature $-40^{\circ}\text{C} \leq T_A \leq +85^{\circ}\text{C}$ for Industrial					
Param. No.	Symbol	Characteristics <sup>(1)</sup>		Min.	Max.	Units	Conditions
TB10	T <sub>TxH</sub>	TxCK High Time	Synchronous, with prescaler	$[(12.5 \text{ ns or } 1 \text{ TPB})/N] + 25 \text{ ns}$	—	ns	Must also meet parameter TB15
TB11	T <sub>TxL</sub>	TxCK Low Time	Synchronous, with prescaler	$[(12.5 \text{ ns or } 1 \text{ TPB})/N] + 25 \text{ ns}$	—	ns	Must also meet parameter TB15
TB15	T <sub>TxP</sub>	TxCK Input Period	Synchronous, with prescaler	$[(\text{Greater of } [(25 \text{ ns or } 2 \text{ TPB})/N] + 30 \text{ ns})]$	—	ns	V <sub>DD</sub> > 2.7V
				$[(\text{Greater of } [(25 \text{ ns or } 2 \text{ TPB})/N] + 50 \text{ ns})]$	—	ns	V <sub>DD</sub> < 2.7V
TB20	T <sub>CKEXTMRL</sub>	Delay from External TxCK Clock Edge to Timer Increment		—	1	TPB	—

**Note 1:** These parameters are characterized, but not tested in manufacturing.

**FIGURE 31-7: INPUT CAPTURE (CAPx) TIMING CHARACTERISTICS**



**Note:** Refer to Figure 31-1 for load conditions.

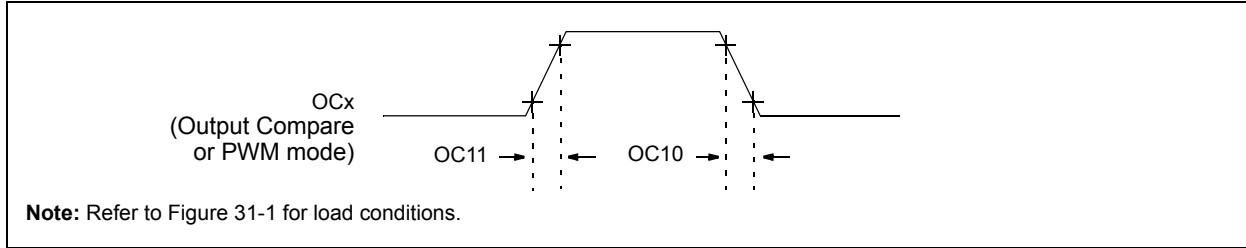
**TABLE 31-25: INPUT CAPTURE MODULE TIMING REQUIREMENTS**

AC CHARACTERISTICS		Standard Operating Conditions: 2.3V to 3.6V (unless otherwise stated) Operating temperature $-40^{\circ}\text{C} \leq T_A \leq +85^{\circ}\text{C}$ for Industrial					
Param. No.	Symbol	Characteristics <sup>(1)</sup>		Min.	Max.	Units	Conditions
IC10	T <sub>cCL</sub>	ICx Input Low Time		$[(12.5 \text{ ns or } 1 \text{ TPB})/N] + 25 \text{ ns}$	—	ns	Must also meet parameter IC15.
IC11	T <sub>cCH</sub>	ICx Input High Time		$[(12.5 \text{ ns or } 1 \text{ TPB})/N] + 25 \text{ ns}$	—	ns	Must also meet parameter IC15.
IC15	T <sub>cCP</sub>	ICx Input Period		$[(25 \text{ ns or } 2 \text{ TPB})/N] + 50 \text{ ns}$	—	ns	—

**Note 1:** These parameters are characterized, but not tested in manufacturing.

# PIC32MX5XX/6XX/7XX

**FIGURE 31-8: OUTPUT COMPARE MODULE (OCx) TIMING CHARACTERISTICS**

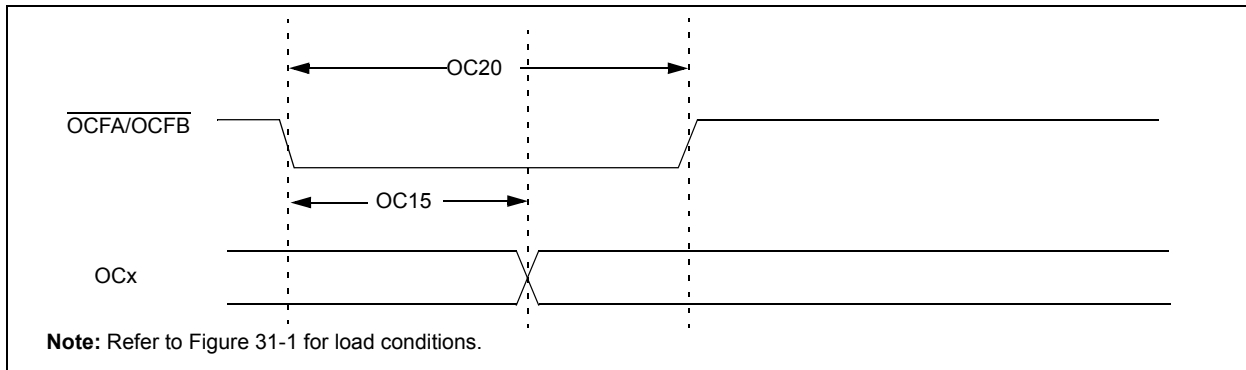


**TABLE 31-26: OUTPUT COMPARE MODULE TIMING REQUIREMENTS**

AC CHARACTERISTICS			Standard Operating Conditions: 2.3V to 3.6V (unless otherwise stated) Operating temperature $-40^{\circ}\text{C} \leq T_A \leq +85^{\circ}\text{C}$ for Industrial				
Param. No.	Symbol	Characteristics <sup>(1)</sup>	Min.	Typical <sup>(2)</sup>	Max.	Units	Conditions
OC10	TccF	OCx Output Fall Time	—	—	—	ns	See parameter DO32
OC11	TccR	OCx Output Rise Time	—	—	—	ns	See parameter DO31

- Note 1:** These parameters are characterized, but not tested in manufacturing.  
**Note 2:** Data in “Typical” column is at 3.3V, 25°C unless otherwise stated. Parameters are for design guidance only and are not tested.

**FIGURE 31-9: OCx/PWM MODULE TIMING CHARACTERISTICS**

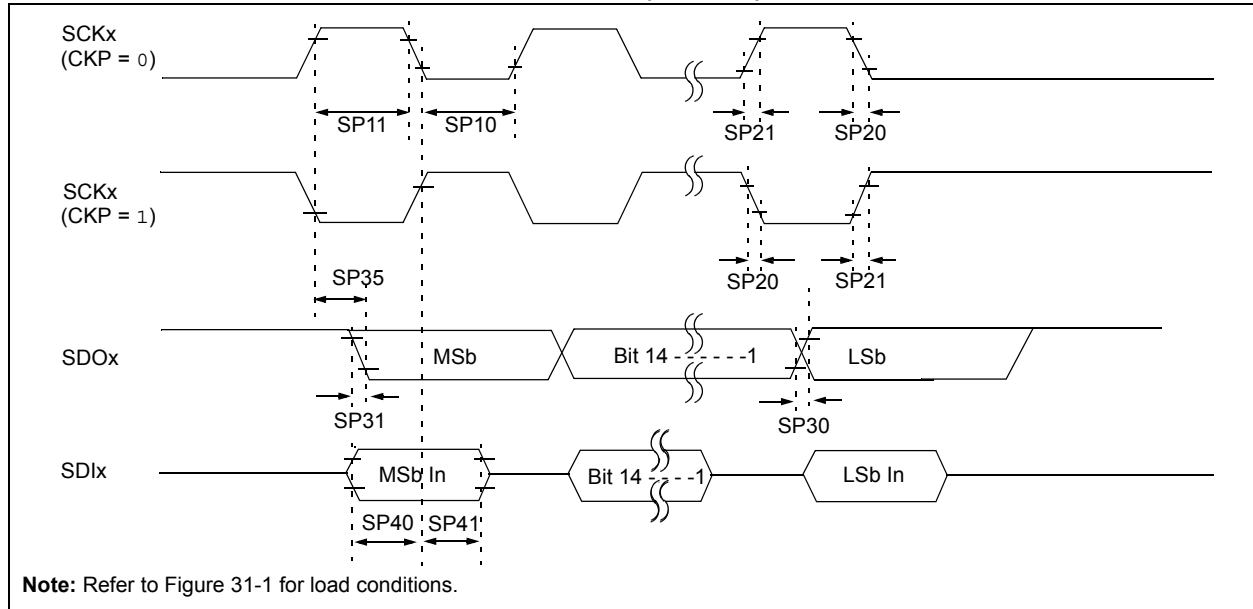


**TABLE 31-27: SIMPLE OCx/PWM MODE TIMING REQUIREMENTS**

AC CHARACTERISTICS			Standard Operating Conditions: 2.3V to 3.6V (unless otherwise stated) Operating temperature $-40^{\circ}\text{C} \leq T_A \leq +85^{\circ}\text{C}$ for Industrial				
Param No.	Symbol	Characteristics <sup>(1)</sup>	Min	Typical <sup>(2)</sup>	Max	Units	Conditions
OC15	TfD	Fault Input to PWM I/O Change	—	—	50	ns	—
OC20	TfLT	Fault Input Pulse Width	50	—	—	ns	—

- Note 1:** These parameters are characterized, but not tested in manufacturing.  
**Note 2:** Data in “Typical” column is at 3.3V, 25°C unless otherwise stated. Parameters are for design guidance only and are not tested.

**FIGURE 31-10: SPIx MODULE MASTER MODE (CKE = 0) TIMING CHARACTERISTICS**



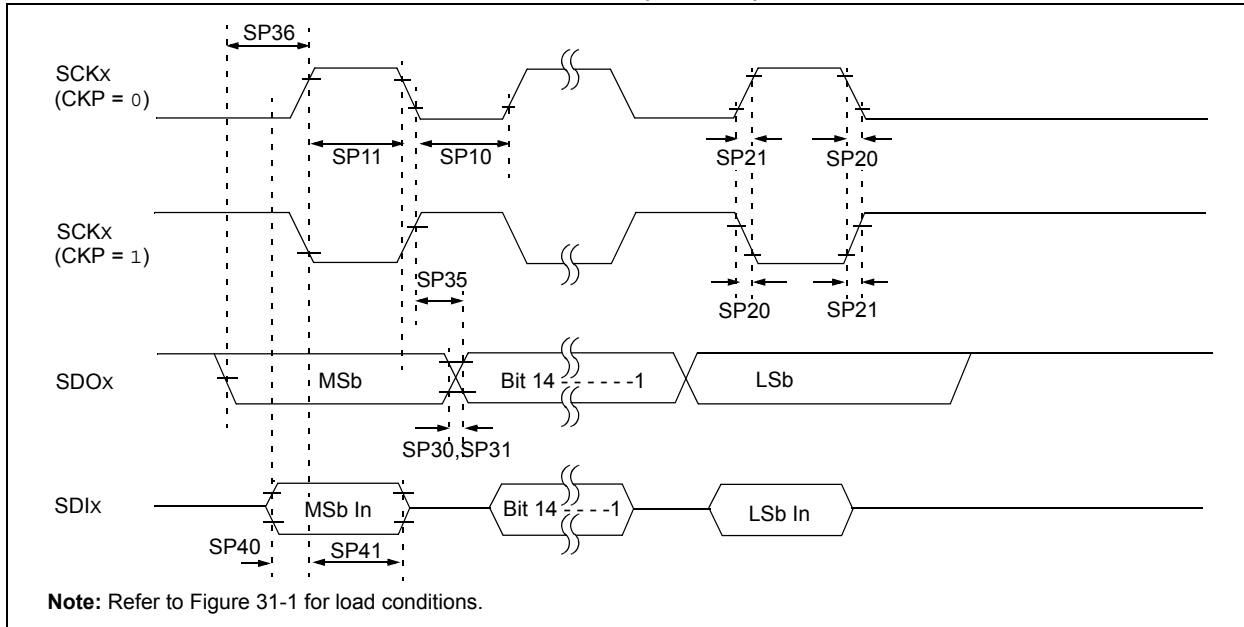
**TABLE 31-28: SPIx MASTER MODE (CKE = 0) TIMING REQUIREMENTS**

AC CHARACTERISTICS			Standard Operating Conditions: 2.3V to 3.6V (unless otherwise stated) Operating temperature $-40^{\circ}\text{C} \leq T_A \leq +85^{\circ}\text{C}$ for Industrial				
Param. No.	Symbol	Characteristics <sup>(1)</sup>	Min.	Typical <sup>(2)</sup>	Max.	Units	Conditions
SP10	TsCL	SCKx Output Low Time (Note 3)	$T_{\text{SCK}}/2$	—	—	ns	—
SP11	TsCH	SCKx Output High Time (Note 3)	$T_{\text{SCK}}/2$	—	—	ns	—
SP20	TscF	SCKx Output Fall Time (Note 4)	—	—	—	ns	See parameter DO32
SP21	TscR	SCKx Output Rise Time (Note 4)	—	—	—	ns	See parameter DO31
SP30	TdoF	SDOx Data Output Fall Time (Note 4)	—	—	—	ns	See parameter DO32
SP31	TdoR	SDOx Data Output Rise Time (Note 4)	—	—	—	ns	See parameter DO31
SP35	TsCH2doV, TsCL2doV	SDOx Data Output Valid after SCKx Edge	—	—	15	ns	$V_{\text{DD}} > 2.7\text{V}$
			—	—	20	ns	$V_{\text{DD}} < 2.7\text{V}$
SP40	TdiV2sch, TdiV2scl	Setup Time of SDIx Data Input to SCKx Edge	10	—	—	ns	—
SP41	Tsch2diL, Tscl2diL	Hold Time of SDIx Data Input to SCKx Edge	10	—	—	ns	—

- Note 1:** These parameters are characterized, but not tested in manufacturing.
- Note 2:** Data in “Typical” column is at 3.3V, 25°C unless otherwise stated. Parameters are for design guidance only and are not tested.
- Note 3:** The minimum clock period for SCKx is 40 ns. Therefore, the clock generated in Master mode must not violate this specification.
- Note 4:** Assumes 50 pF load on all SPIx pins.

# PIC32MX5XX/6XX/7XX

**FIGURE 31-11: SPIx MODULE MASTER MODE (CKE = 1) TIMING CHARACTERISTICS**



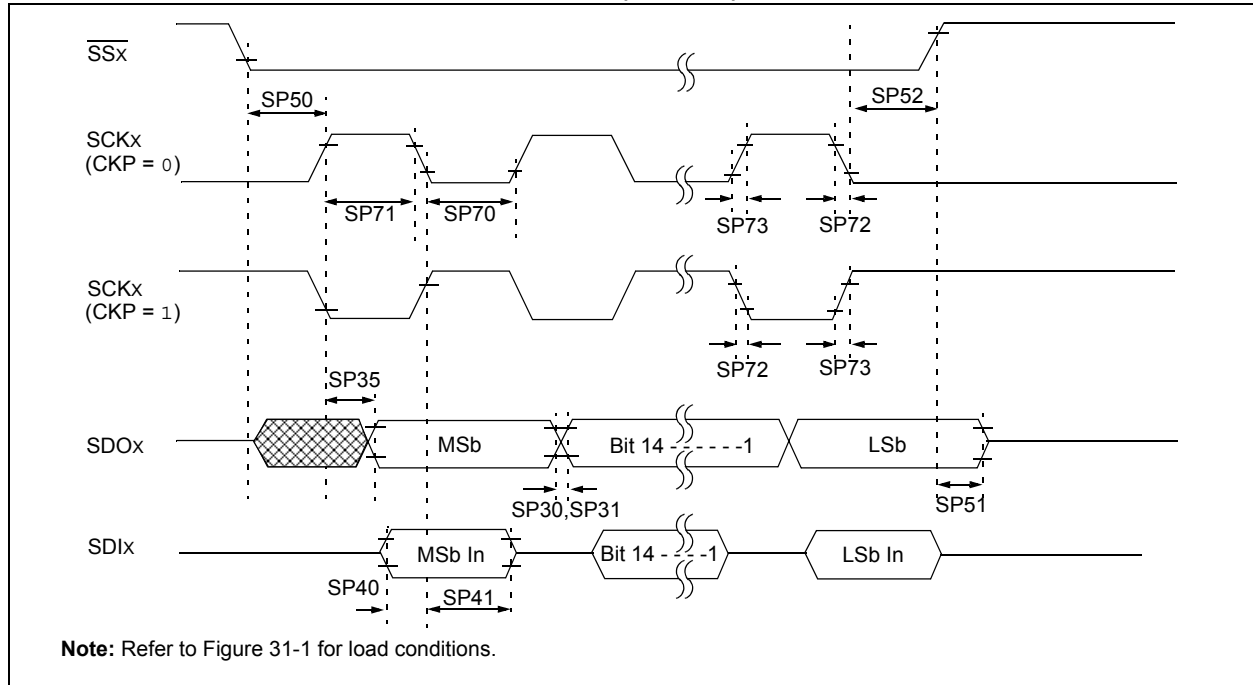
**TABLE 31-29: SPIx MODULE MASTER MODE (CKE = 1) TIMING REQUIREMENTS**

AC CHARACTERISTICS			Standard Operating Conditions: 2.3V to 3.6V (unless otherwise stated) Operating temperature $-40^{\circ}\text{C} \leq T_A \leq +85^{\circ}\text{C}$ for Industrial				
Param. No.	Symbol	Characteristics <sup>(1)</sup>	Min.	Typ. <sup>(2)</sup>	Max.	Units	Conditions
SP10	TscL	SCKx Output Low Time ( <b>Note 3</b> )	$T_{\text{SCK}}/2$	—	—	ns	—
SP11	Tsch	SCKx Output High Time ( <b>Note 3</b> )	$T_{\text{SCK}}/2$	—	—	ns	—
SP20	TscF	SCKx Output Fall Time ( <b>Note 4</b> )	—	—	—	ns	See parameter DO32
SP21	TscR	SCKx Output Rise Time ( <b>Note 4</b> )	—	—	—	ns	See parameter DO31
SP30	TdoF	SDOx Data Output Fall Time ( <b>Note 4</b> )	—	—	—	ns	See parameter DO32
SP31	TdoR	SDOx Data Output Rise Time ( <b>Note 4</b> )	—	—	—	ns	See parameter DO31
SP35	Tsch2doV, TscL2doV	SDOx Data Output Valid after SCKx Edge	—	—	15	ns	$V_{\text{DD}} > 2.7\text{V}$
			—	—	20	ns	$V_{\text{DD}} < 2.7\text{V}$
SP36	TdoV2scL, TdoV2scH	SDOx Data Output Setup to First SCKx Edge	15	—	—	ns	—
SP40	TdiV2scH, TdiV2scL	Setup Time of SDIx Data Input to SCKx Edge	15	—	—	ns	$V_{\text{DD}} > 2.7\text{V}$
			20	—	—	ns	$V_{\text{DD}} < 2.7\text{V}$
SP41	Tsch2diL, TscL2diL	Hold Time of SDIx Data Input to SCKx Edge	15	—	—	ns	$V_{\text{DD}} > 2.7\text{V}$
			20	—	—	ns	$V_{\text{DD}} < 2.7\text{V}$

- Note 1:** These parameters are characterized, but not tested in manufacturing.
- Note 2:** Data in “Typical” column is at 3.3V, 25°C unless otherwise stated. Parameters are for design guidance only and are not tested.
- Note 3:** The minimum clock period for SCKx is 40 ns. Therefore, the clock generated in Master mode must not violate this specification.
- Note 4:** Assumes 50 pF load on all SPIx pins.



**FIGURE 31-12: SPIx MODULE SLAVE MODE (CKE = 0) TIMING CHARACTERISTICS**



**TABLE 31-30: SPIx MODULE SLAVE MODE (CKE = 0) TIMING REQUIREMENTS**

AC CHARACTERISTICS			Standard Operating Conditions: 2.3V to 3.6V (unless otherwise stated) Operating temperature $-40^{\circ}\text{C} \leq T_A \leq +85^{\circ}\text{C}$ for Industrial				
Param. No.	Symbol	Characteristics <sup>(1)</sup>	Min.	Typ. <sup>(2)</sup>	Max.	Units	Conditions
SP70	TscL	SCKx Input Low Time ( <b>Note 3</b> )	$T_{\text{SCK}}/2$	—	—	ns	—
SP71	TscH	SCKx Input High Time ( <b>Note 3</b> )	$T_{\text{SCK}}/2$	—	—	ns	—
SP72	TscF	SCKx Input Fall Time	—	—	—	ns	See parameter DO32
SP73	TscR	SCKx Input Rise Time	—	—	—	ns	See parameter DO31
SP30	TdoF	SDOx Data Output Fall Time ( <b>Note 4</b> )	—	—	—	ns	See parameter DO32
SP31	TdoR	SDOx Data Output Rise Time ( <b>Note 4</b> )	—	—	—	ns	See parameter DO31
SP35	Tsch2doV, TscL2doV	SDOx Data Output Valid after SCKx Edge	—	—	15	ns	$V_{\text{DD}} > 2.7\text{V}$
			—	—	20	ns	$V_{\text{DD}} < 2.7\text{V}$
SP40	TdIV2sch, TdIV2scL	Setup Time of SDIx Data Input to SCKx Edge	10	—	—	ns	—
SP41	Tsch2diL, TscL2diL	Hold Time of SDIx Data Input to SCKx Edge	10	—	—	ns	—
SP50	TssL2sch, TssL2scL	$\overline{\text{SSx}} \downarrow$ to SCKx $\uparrow$ or SCKx Input	175	—	—	ns	—
SP51	Tssh2doZ	$\overline{\text{SSx}} \uparrow$ to SDOx Output High-Impedance ( <b>Note 3</b> )	5	—	25	ns	—
SP52	Tsch2ssh, TscL2ssh	$\overline{\text{SSx}}$ after SCKx Edge	$T_{\text{SCK}} + 20$	—	—	ns	—

**Note 1:** These parameters are characterized, but not tested in manufacturing.

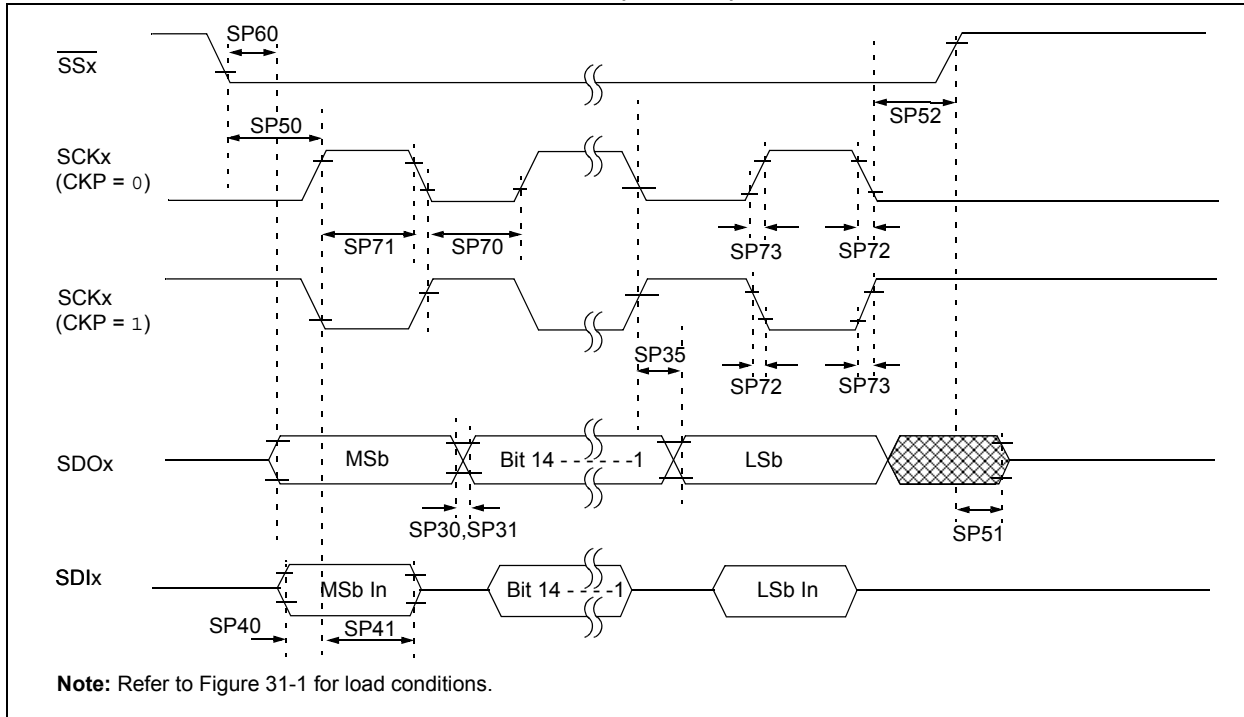
**2:** Data in “Typical” column is at 3.3V, 25°C unless otherwise stated. Parameters are for design guidance only and are not tested.

**3:** The minimum clock period for SCKx is 40 ns.

**4:** Assumes 50 pF load on all SPIx pins.

# PIC32MX5XX/6XX/7XX

**FIGURE 31-13: SPIx MODULE SLAVE MODE (CKE = 1) TIMING CHARACTERISTICS**



**TABLE 31-31: SPIx MODULE SLAVE MODE (CKE = 1) TIMING REQUIREMENTS**

AC CHARACTERISTICS			Standard Operating Conditions: 2.3V to 3.6V (unless otherwise stated) Operating temperature $-40^{\circ}\text{C} \leq T_A \leq +85^{\circ}\text{C}$ for Industrial				
Param. No.	Symbol	Characteristics <sup>(1)</sup>	Min.	Typical <sup>(2)</sup>	Max.	Units	Conditions
SP70	TscL	SCKx Input Low Time ( <b>Note 3</b> )	$T_{\text{SCK}}/2$	—	—	ns	—
SP71	Tsch	SCKx Input High Time ( <b>Note 3</b> )	$T_{\text{SCK}}/2$	—	—	ns	—
SP72	TscF	SCKx Input Fall Time	—	5	10	ns	—
SP73	TscR	SCKx Input Rise Time	—	5	10	ns	—
SP30	TdoF	SDOx Data Output Fall Time ( <b>Note 4</b> )	—	—	—	ns	See parameter DO32
SP31	TdoR	SDOx Data Output Rise Time ( <b>Note 4</b> )	—	—	—	ns	See parameter DO31
SP35	Tsch2doV, TscL2doV	SDOx Data Output Valid after SCKx Edge	—	—	20	ns	$V_{\text{DD}} > 2.7\text{V}$
			—	—	30	ns	$V_{\text{DD}} < 2.7\text{V}$
SP40	TdiV2sch, TdiV2scl	Setup Time of SDIx Data Input to SCKx Edge	10	—	—	ns	—
SP41	Tsch2diL, TscL2diL	Hold Time of SDIx Data Input to SCKx Edge	10	—	—	ns	—
SP50	TssL2sch, TssL2scl	$\overline{\text{SSx}} \downarrow$ to SCKx $\downarrow$ or SCKx $\uparrow$ Input	175	—	—	ns	—

**Note 1:** These parameters are characterized, but not tested in manufacturing.

**Note 2:** Data in “Typical” column is at 3.3V, 25°C unless otherwise stated. Parameters are for design guidance only and are not tested.

**Note 3:** The minimum clock period for SCKx is 40 ns.

**Note 4:** Assumes 50 pF load on all SPIx pins.

**TABLE 31-31: SPIx MODULE SLAVE MODE (CKE = 1) TIMING REQUIREMENTS (CONTINUED)**

AC CHARACTERISTICS			Standard Operating Conditions: 2.3V to 3.6V (unless otherwise stated) Operating temperature $-40^{\circ}\text{C} \leq T_A \leq +85^{\circ}\text{C}$ for Industrial				
Param. No.	Symbol	Characteristics <sup>(1)</sup>	Min.	Typical <sup>(2)</sup>	Max.	Units	Conditions
SP51	TssH2doZ	$\overline{\text{SS}}_x \uparrow$ to SDOx Output High-Impedance <b>(Note 4)</b>	5	—	25	ns	—
SP52	Tsch2ssH TscL2ssH	$\overline{\text{SS}}_x \uparrow$ after SCKx Edge	Tsck + 20	—	—	ns	—
SP60	TssL2boV	SDOx Data Output Valid after $\overline{\text{SS}}_x$ Edge	—	—	25	ns	—

**Note 1:** These parameters are characterized, but not tested in manufacturing.

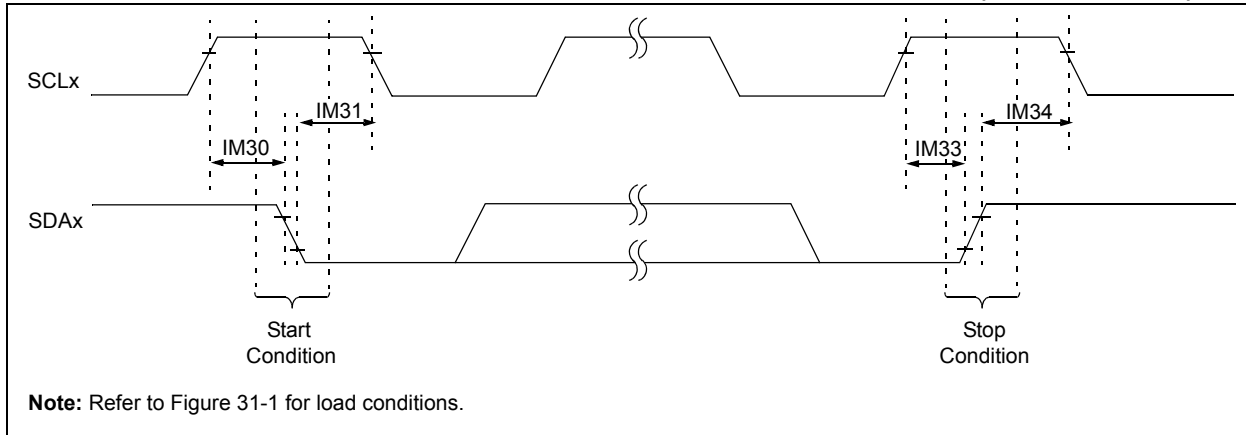
**2:** Data in “Typical” column is at 3.3V, 25°C unless otherwise stated. Parameters are for design guidance only and are not tested.

**3:** The minimum clock period for SCKx is 40 ns.

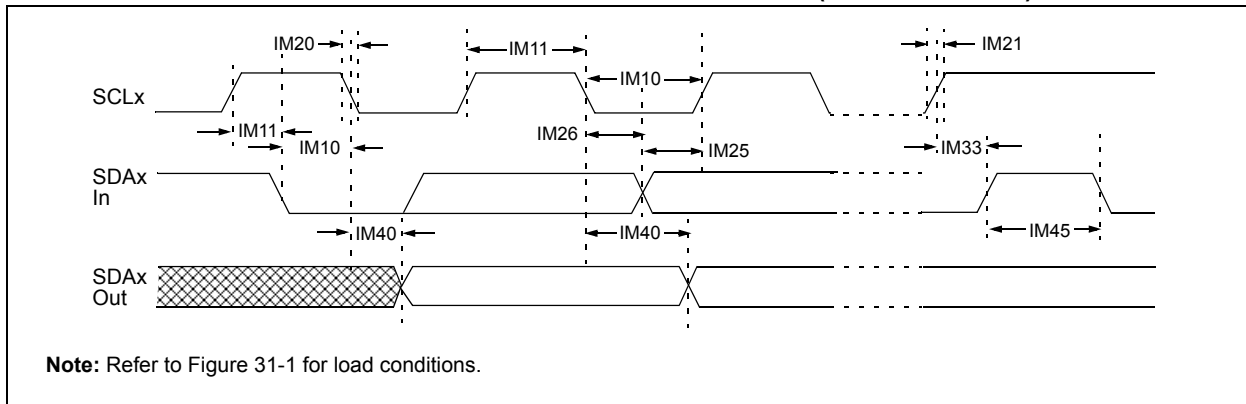
**4:** Assumes 50 pF load on all SPIx pins.

# PIC32MX5XX/6XX/7XX

**FIGURE 31-14: I2Cx BUS START/STOP BITS TIMING CHARACTERISTICS (MASTER MODE)**



**FIGURE 31-15: I2Cx BUS DATA TIMING CHARACTERISTICS (MASTER MODE)**



**TABLE 31-32: I2Cx BUS DATA TIMING REQUIREMENTS (MASTER MODE)**

AC CHARACTERISTICS			Standard Operating Conditions: 2.3V to 3.6V (unless otherwise stated) Operating temperature $-40^{\circ}\text{C} \leq T_A \leq +85^{\circ}\text{C}$ for Industrial				
Param. No.	Symbol	Characteristics	Min. <sup>(1)</sup>	Max.	Units	Conditions	
IM10	TLO:SCL	Clock Low Time	100 kHz mode	$T_{PB} * (BRG + 2)$	—	$\mu\text{s}$	—
			400 kHz mode	$T_{PB} * (BRG + 2)$	—	$\mu\text{s}$	—
			1 MHz mode (Note 2)	$T_{PB} * (BRG + 2)$	—	$\mu\text{s}$	—
IM11	THI:SCL	Clock High Time	100 kHz mode	$T_{PB} * (BRG + 2)$	—	$\mu\text{s}$	—
			400 kHz mode	$T_{PB} * (BRG + 2)$	—	$\mu\text{s}$	—
			1 MHz mode (Note 2)	$T_{PB} * (BRG + 2)$	—	$\mu\text{s}$	—
IM20	TF:SCL	SDAx and SCLx Fall Time	100 kHz mode	—	300	ns	Cb is specified to be from 10 to 400 pF
			400 kHz mode	$20 + 0.1 C_b$	300	ns	
			1 MHz mode (Note 2)	—	100	ns	
IM21	TR:SCL	SDAx and SCLx Rise Time	100 kHz mode	—	1000	ns	Cb is specified to be from 10 to 400 pF
			400 kHz mode	$20 + 0.1 C_b$	300	ns	
			1 MHz mode (Note 2)	—	300	ns	
IM25	TSU:DAT	Data Input Setup Time	100 kHz mode	250	—	ns	—
			400 kHz mode	100	—	ns	
			1 MHz mode (Note 2)	100	—	ns	
IM26	THD:DAT	Data Input Hold Time	100 kHz mode	0	—	$\mu\text{s}$	—
			400 kHz mode	0	0.9	$\mu\text{s}$	
			1 MHz mode (Note 2)	0	0.3	$\mu\text{s}$	
IM30	TSU:STA	Start Condition Setup Time	100 kHz mode	$T_{PB} * (BRG + 2)$	—	$\mu\text{s}$	Only relevant for Repeated Start condition
			400 kHz mode	$T_{PB} * (BRG + 2)$	—	$\mu\text{s}$	
			1 MHz mode (Note 2)	$T_{PB} * (BRG + 2)$	—	$\mu\text{s}$	
IM31	THD:STA	Start Condition Hold Time	100 kHz mode	$T_{PB} * (BRG + 2)$	—	$\mu\text{s}$	After this period, the first clock pulse is generated
			400 kHz mode	$T_{PB} * (BRG + 2)$	—	$\mu\text{s}$	
			1 MHz mode (Note 2)	$T_{PB} * (BRG + 2)$	—	$\mu\text{s}$	
IM33	TSU:STO	Stop Condition Setup Time	100 kHz mode	$T_{PB} * (BRG + 2)$	—	$\mu\text{s}$	—
			400 kHz mode	$T_{PB} * (BRG + 2)$	—	$\mu\text{s}$	
			1 MHz mode (Note 2)	$T_{PB} * (BRG + 2)$	—	$\mu\text{s}$	
IM34	THD:STO	Stop Condition Hold Time	100 kHz mode	$T_{PB} * (BRG + 2)$	—	ns	—
			400 kHz mode	$T_{PB} * (BRG + 2)$	—	ns	
			1 MHz mode (Note 2)	$T_{PB} * (BRG + 2)$	—	ns	

**Note 1:** BRG is the value of the I<sup>2</sup>C™ Baud Rate Generator.

**2:** Maximum pin capacitance = 10 pF for all I2Cx pins (for 1 MHz mode only).

# PIC32MX5XX/6XX/7XX

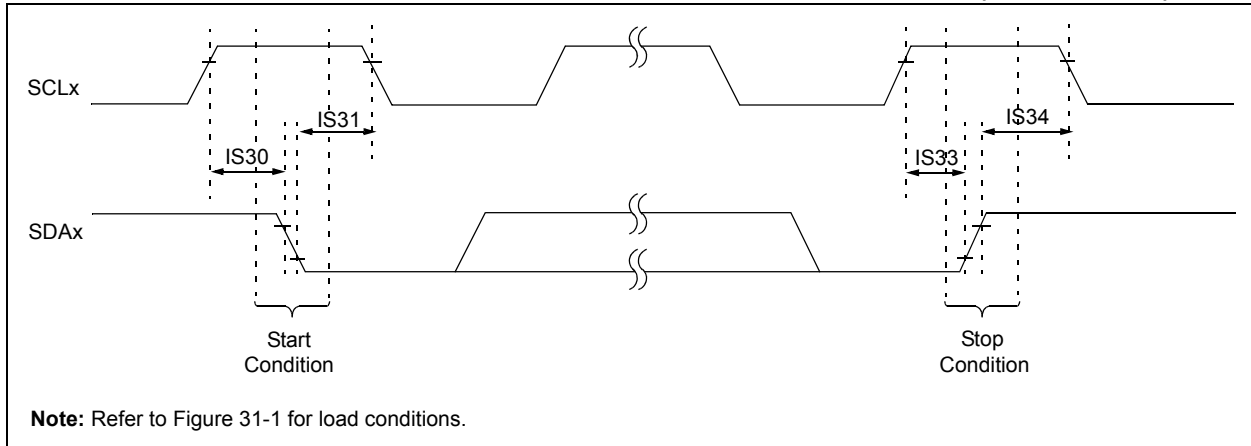
**TABLE 31-32: I2Cx BUS DATA TIMING REQUIREMENTS (MASTER MODE) (CONTINUED)**

AC CHARACTERISTICS			Standard Operating Conditions: 2.3V to 3.6V (unless otherwise stated) Operating temperature $-40^{\circ}\text{C} \leq T_A \leq +85^{\circ}\text{C}$ for Industrial				
Param. No.	Symbol	Characteristics	Min. <sup>(1)</sup>	Max.	Units	Conditions	
IM40	TAA:SCL	Output Valid From Clock	100 kHz mode	—	3500	ns	—
			400 kHz mode	—	1000	ns	—
			1 MHz mode <b>(Note 2)</b>	—	350	ns	—
IM45	TBF:SDA	Bus Free Time	100 kHz mode	4.7	—	$\mu\text{s}$	The amount of time the bus must be free before a new transmission can start
			400 kHz mode	1.3	—	$\mu\text{s}$	
			1 MHz mode <b>(Note 2)</b>	0.5	—	$\mu\text{s}$	
IM50	CB	Bus Capacitive Loading	—	400	pF	—	

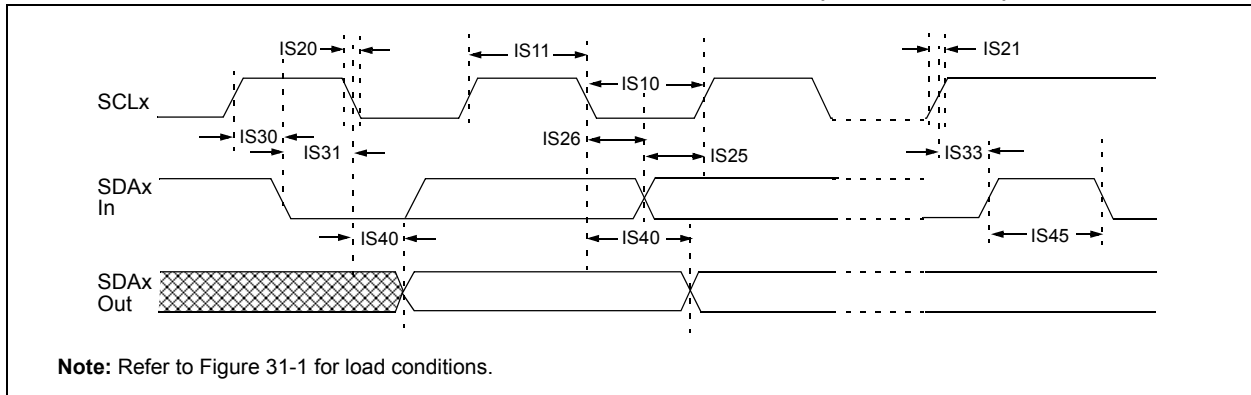
**Note 1:** BRG is the value of the I<sup>2</sup>C™ Baud Rate Generator.

**Note 2:** Maximum pin capacitance = 10 pF for all I2Cx pins (for 1 MHz mode only).

**FIGURE 31-16: I2Cx BUS START/STOP BITS TIMING CHARACTERISTICS (SLAVE MODE)**



**FIGURE 31-17: I2Cx BUS DATA TIMING CHARACTERISTICS (SLAVE MODE)**



# PIC32MX5XX/6XX/7XX

**TABLE 31-33: I2Cx BUS DATA TIMING REQUIREMENTS (SLAVE MODE)**

AC CHARACTERISTICS				Standard Operating Conditions: 2.3V to 3.6V (unless otherwise stated) Operating temperature $-40^{\circ}\text{C} \leq T_A \leq +85^{\circ}\text{C}$ for Industrial			
Param. No.	Symbol	Characteristics		Min.	Max.	Units	Conditions
IS10	TLO:SCL	Clock Low Time	100 kHz mode	4.7	—	$\mu\text{s}$	PBCLK must operate at a minimum of 800 kHz
			400 kHz mode	1.3	—	$\mu\text{s}$	PBCLK must operate at a minimum of 3.2 MHz
			1 MHz mode (Note 1)	0.5	—	$\mu\text{s}$	—
IS11	THI:SCL	Clock High Time	100 kHz mode	4.0	—	$\mu\text{s}$	PBCLK must operate at a minimum of 800 kHz
			400 kHz mode	0.6	—	$\mu\text{s}$	PBCLK must operate at a minimum of 3.2 MHz
			1 MHz mode (Note 1)	0.5	—	$\mu\text{s}$	—
IS20	TF:SCL	SDAx and SCLx Fall Time	100 kHz mode	—	300	ns	Cb is specified to be from 10 to 400 pF
			400 kHz mode	$20 + 0.1 C_B$	300	ns	
			1 MHz mode (Note 1)	—	100	ns	
IS21	TR:SCL	SDAx and SCLx Rise Time	100 kHz mode	—	1000	ns	Cb is specified to be from 10 to 400 pF
			400 kHz mode	$20 + 0.1 C_B$	300	ns	
			1 MHz mode (Note 1)	—	300	ns	
IS25	TSU:DAT	Data Input Setup Time	100 kHz mode	250	—	ns	—
			400 kHz mode	100	—	ns	
			1 MHz mode (Note 1)	100	—	ns	
IS26	THD:DAT	Data Input Hold Time	100 kHz mode	0	—	ns	—
			400 kHz mode	0	0.9	$\mu\text{s}$	
			1 MHz mode (Note 1)	0	0.3	$\mu\text{s}$	
IS30	TSU:STA	Start Condition Setup Time	100 kHz mode	4700	—	$\mu\text{s}$	Only relevant for Repeated Start condition
			400 kHz mode	600	—	$\mu\text{s}$	
			1 MHz mode (Note 1)	250	—	$\mu\text{s}$	
IS31	THD:STA	Start Condition Hold Time	100 kHz mode	4000	—	$\mu\text{s}$	After this period, the first clock pulse is generated
			400 kHz mode	600	—	$\mu\text{s}$	
			1 MHz mode (Note 1)	250	—	$\mu\text{s}$	
IS33	TSU:STO	Stop Condition Setup Time	100 kHz mode	4000	—	$\mu\text{s}$	—
			400 kHz mode	600	—	$\mu\text{s}$	
			1 MHz mode (Note 1)	600	—	$\mu\text{s}$	

**Note 1:** Maximum pin capacitance = 10 pF for all I2Cx pins (for 1 MHz mode only).



# PIC32MX5XX/6XX/7XX

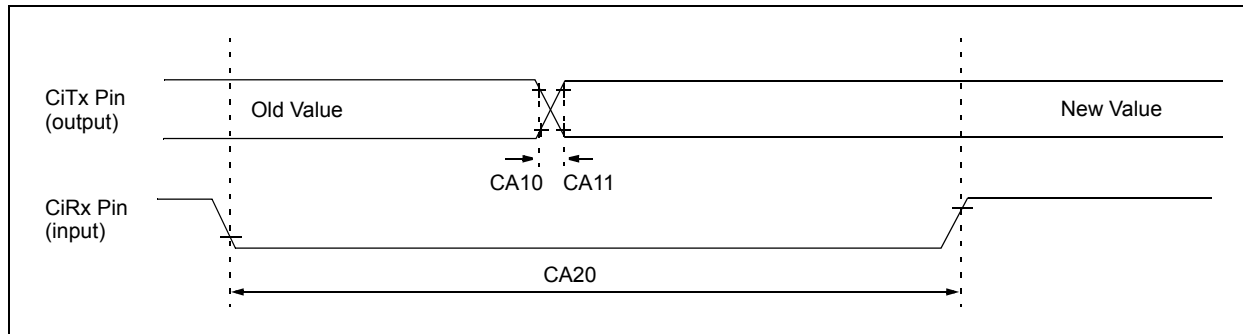
**TABLE 31-33: I2Cx BUS DATA TIMING REQUIREMENTS (SLAVE MODE) (CONTINUED)**

AC CHARACTERISTICS				Standard Operating Conditions: 2.3V to 3.6V (unless otherwise stated) Operating temperature $-40^{\circ}\text{C} \leq T_A \leq +85^{\circ}\text{C}$ for Industrial			
Param. No.	Symbol	Characteristics		Min.	Max.	Units	Conditions
IS34	THD:STO	Stop Condition Hold Time	100 kHz mode	4000	—	ns	—
			400 kHz mode	600	—	ns	
			1 MHz mode (Note 1)	250	—	ns	
IS40	TAA:SCL	Output Valid From Clock	100 kHz mode	0	3500	ns	—
			400 kHz mode	0	1000	ns	
			1 MHz mode (Note 1)	0	350	ns	
IS45	TBF:SDA	Bus Free Time	100 kHz mode	4.7	—	$\mu\text{s}$	The amount of time the bus must be free before a new transmission can start
			400 kHz mode	1.3	—	$\mu\text{s}$	
			1 MHz mode (Note 1)	0.5	—	$\mu\text{s}$	
IS50	CB	Bus Capacitive Loading		—	400	pF	—

**Note 1:** Maximum pin capacitance = 10 pF for all I2Cx pins (for 1 MHz mode only).

# PIC32MX5XX/6XX/7XX

**FIGURE 31-18: CAN MODULE I/O TIMING CHARACTERISTICS**



**TABLE 31-34: CAN MODULE I/O TIMING REQUIREMENTS**

AC CHARACTERISTICS			Standard Operating Conditions: 2.3V to 3.6V (unless otherwise stated) Operating temperature $-40^{\circ}\text{C} \leq T_A \leq +85^{\circ}\text{C}$ for Industrial				
Param No.	Symbol	Characteristic <sup>(1)</sup>	Min	Typ <sup>(2)</sup>	Max	Units	Conditions
CA10	TioF	Port Output Fall Time	—	—	—	ns	See parameter D032
CA11	TioR	Port Output Rise Time	—	—	—	ns	See parameter D031
CA20	Tcwf	Pulse Width to Trigger CAN Wake-up Filter	700	—	—	ns	—

**Note 1:** These parameters are characterized but not tested in manufacturing.

**2:** Data in “Typ” column is at 3.3V, 25°C unless otherwise stated. Parameters are for design guidance only and are not tested.

# PIC32MX5XX/6XX/7XX

**TABLE 31-35: ETHERNET MODULE SPECIFICATIONS**

<b>AC CHARACTERISTICS</b>		<b>Standard Operating Conditions: 2.5V to 3.6V (unless otherwise stated)</b> Operating temperature $-40^{\circ}\text{C} \leq T_A \leq +85^{\circ}\text{C}$ for Industrial				
<b>Param. No.</b>	<b>Characteristic</b>	<b>Min.</b>	<b>Typical</b>	<b>Max.</b>	<b>Units</b>	<b>Conditions</b>
<b>Device Supply</b>						
ET20a	Module VDD Supply	2.5	—	3.6	V	
ET20b	Module VDD Supply	2.7	—	3.6	V	For RMII mode only
<b>MIIM Timing Requirements</b>						
ET1	MDC Duty Cycle	40	—	60	%	—
ET2	MDC Period	400	—	—	ns	—
ET3	MDIO Output Delay	10	—	10	ns	—
ET4	MDIO Input Delay	0	—	300	ns	—
<b>MII Timing Requirements</b>						
ET5	TX Clock Frequency	—	25	—	MHz	—
ET6	TX Clock Duty Cycle	35	—	65	%	—
ET7	ETXDx, ETEN, ETXERR Delay	0	—	25	ns	—
ET8	RX Clock Frequency	—	25	—	MHz	—
ET9	RX Clock Duty Cycle	35	—	65	%	—
ET10	ERXDx, ERXDV, ERXERR Delay	10	—	30	ns	—
<b>RMII Timing Requirements</b>						
ET11	Reference Clock Frequency	—	50	—	MHz	—
ET12	Reference Clock Duty Cycle	35	—	65	%	—
ET13	ETXDx, ETEN, Delay	2	—	16	ns	—
ET14	ERXDx, ERXDV, ERXERR Delay	2	—	16	ns	—

# PIC32MX5XX/6XX/7XX

**TABLE 31-36: ADC MODULE SPECIFICATIONS**

AC CHARACTERISTICS			Standard Operating Conditions: 2.5V to 3.6V (unless otherwise stated) Operating temperature $-40^{\circ}\text{C} \leq T_A \leq +85^{\circ}\text{C}$ for Industrial				
Param. No.	Symbol	Characteristics	Min.	Typical	Max.	Units	Conditions
<b>Device Supply</b>							
AD01	AVDD	Module VDD Supply	Greater of VDD – 0.3 or 2.5	—	Lesser of VDD + 0.3 or 3.6	V	—
AD02	AVSS	Module VSS Supply	VSS	—	VSS + 0.3	V	—
<b>Reference Inputs</b>							
AD05	VREFH	Reference Voltage High	AVSS + 2.0	—	AVDD	V	<b>(Note 1)</b>
AD05a			2.5	—	3.6	V	VREFH = AVDD <b>(Note 3)</b>
AD06	VREFL	Reference Voltage Low	AVSS	—	VREFH – 2.0	V	<b>(Note 1)</b>
AD07	VREF	Absolute Reference Voltage (VREFH – VREFL)	2.0	—	AVDD	V	<b>(Note 3)</b>
AD08	IREF	Current Drain	—	250 —	400 3	$\mu\text{A}$ $\mu\text{A}$	ADC operating ADC off
<b>Analog Input</b>							
AD12	VINH-VINL	Full-Scale Input Span	VREFL	—	VREFH	V	—
	VINL	Absolute VINL Input Voltage	AVSS – 0.3	—	AVDD/2	V	—
	VIN	Absolute Input Voltage	AVSS – 0.3	—	AVDD + 0.3	V	—
		Leakage Current	—	+/- 0.001	+/-0.610	$\mu\text{A}$	VINL = AVSS = VREFL = 0V, AVDD = VREFH = 3.3V Source Impedance = 10 k $\Omega$
AD17	RIN	Recommended Impedance of Analog Voltage Source	—	—	5K	$\Omega$	<b>(Note 1)</b>
<b>ADC Accuracy – Measurements with External VREF+/VREF-</b>							
AD20c	Nr	Resolution	10 data bits			bits	—
AD21c	INL	Integral Nonlinearity	> -1	—	< 1	LSb	VINL = AVSS = VREFL = 0V, AVDD = VREFH = 3.3V
AD22c	DNL	Differential Nonlinearity	> -1	—	< 1	LSb	VINL = AVSS = VREFL = 0V, AVDD = VREFH = 3.3V <b>(Note 2)</b>
AD23c	GERR	Gain Error	> -1	—	< 1	LSb	VINL = AVSS = VREFL = 0V, AVDD = VREFH = 3.3V
AD24n	EOFF	Offset Error	> -1	—	< 1	LSb	VINL = AVSS = 0V, AVDD = 3.3V
AD25c	—	Monotonicity	—	—	—	—	Guaranteed

**Note 1:** These parameters are not characterized or tested in manufacturing.

**2:** With no missing codes.

**3:** These parameters are characterized, but not tested in manufacturing.

**4:** Characterized with a 1 kHz sinewave.

# PIC32MX5XX/6XX/7XX

**TABLE 31-36: ADC MODULE SPECIFICATIONS (CONTINUED)**

AC CHARACTERISTICS			Standard Operating Conditions: 2.5V to 3.6V (unless otherwise stated) Operating temperature $-40^{\circ}\text{C} \leq T_A \leq +85^{\circ}\text{C}$ for Industrial				
Param. No.	Symbol	Characteristics	Min.	Typical	Max.	Units	Conditions
<b>ADC Accuracy – Measurements with Internal VREF+/VREF-</b>							
AD20d	Nr	Resolution	10 data bits			bits	(Note 3)
AD21d	INL	Integral Nonlinearity	> -1	—	< 1	LSb	V <sub>INL</sub> = AV <sub>SS</sub> = 0V, AV <sub>DD</sub> = 2.5V to 3.6V (Note 3)
AD22d	DNL	Differential Nonlinearity	> -1	—	< 1	LSb	V <sub>INL</sub> = AV <sub>SS</sub> = 0V, AV <sub>DD</sub> = 2.5V to 3.6V (Notes 2,3)
AD23d	GERR	Gain Error	> -4	—	< 4	LSb	V <sub>INL</sub> = AV <sub>SS</sub> = 0V, AV <sub>DD</sub> = 2.5V to 3.6V (Note 3)
AD24d	E <sub>OFF</sub>	Offset Error	> -2	—	< 2	LSb	V <sub>INL</sub> = AV <sub>SS</sub> = 0V, AV <sub>DD</sub> = 2.5V to 3.6V (Note 3)
AD25d	—	Monotonicity	—	—	—	—	Guaranteed
<b>Dynamic Performance</b>							
AD31b	SINAD	Signal to Noise and Distortion	55	58.5	—	dB	(Notes 3,4)
AD34b	ENOB	Effective Number of Bits	9.0	9.5	—	bits	(Notes 3,4)

- Note 1:** These parameters are not characterized or tested in manufacturing.  
**2:** With no missing codes.  
**3:** These parameters are characterized, but not tested in manufacturing.  
**4:** Characterized with a 1 kHz sinewave.

# PIC32MX5XX/6XX/7XX

**TABLE 31-37: 10-BIT CONVERSION RATE PARAMETERS**

PIC32MX 10-bit A/D Converter Conversion Rates <sup>(2)</sup>						
ADC Speed	TAD Minimum	Sampling Time Min	Rs Max	VDD	Temperature	ADC Channels Configuration
1 Msp to 400 ksp <sup>(1)</sup>	65 ns	132 ns	500Ω	3.0V to 3.6V	-40°C to +85°C	
Up to 400 ksp	200 ns	200 ns	5.0 kΩ	2.5V to 3.6V	-40°C to +85°C	
Up to 300 ksp	200 ns	200 ns	5.0 kΩ	2.5V to 3.6V	-40°C to +85°C	

**Note 1:** External VREF- and VREF+ pins must be used for correct operation.

**Note 2:** These parameters are characterized, but not tested in manufacturing.

**TABLE 31-38: A/D CONVERSION TIMING REQUIREMENTS**

AC CHARACTERISTICS			Standard Operating Conditions: 2.5V to 3.6V (unless otherwise stated) Operating temperature $-40^{\circ}\text{C} \leq T_A \leq +85^{\circ}\text{C}$ for Industrial				
Param. No.	Symbol	Characteristics	Min.	Typical <sup>(1)</sup>	Max.	Units	Conditions
<b>Clock Parameters</b>							
AD50	TAD	A/D Clock Period <sup>(2)</sup>	65	—	—	ns	See Table 31-37
<b>Conversion Rate</b>							
AD55	TCONV	Conversion Time	—	12 TAD	—	—	—
AD56	FCNV	Throughput Rate (Sampling Speed)	—	—	1000	ksps	AVDD = 3.0V to 3.6V
			—	—	400	ksps	AVDD = 2.5V to 3.6V
AD57	TSAMP	Sample Time	1	—	31	TAD	TSAMP must be $\geq 132$ ns
<b>Timing Parameters</b>							
AD60	TPCS	Conversion Start from Sample Trigger <sup>(3)</sup>	—	1.0 TAD	—	—	Auto-Convert Trigger (SSRC<2:0> = 111) not selected
AD61	TPSS	Sample Start from Setting Sample (SAMP) bit	0.5 TAD	—	1.5 TAD	—	—
AD62	TCSS	Conversion Completion to Sample Start (ASAM = 1) <sup>(3)</sup>	—	0.5 TAD	—	—	—
AD63	TDFU	Time to Stabilize Analog Stage from A/D Off to A/D On <sup>(3)</sup>	—	—	2	$\mu\text{s}$	—

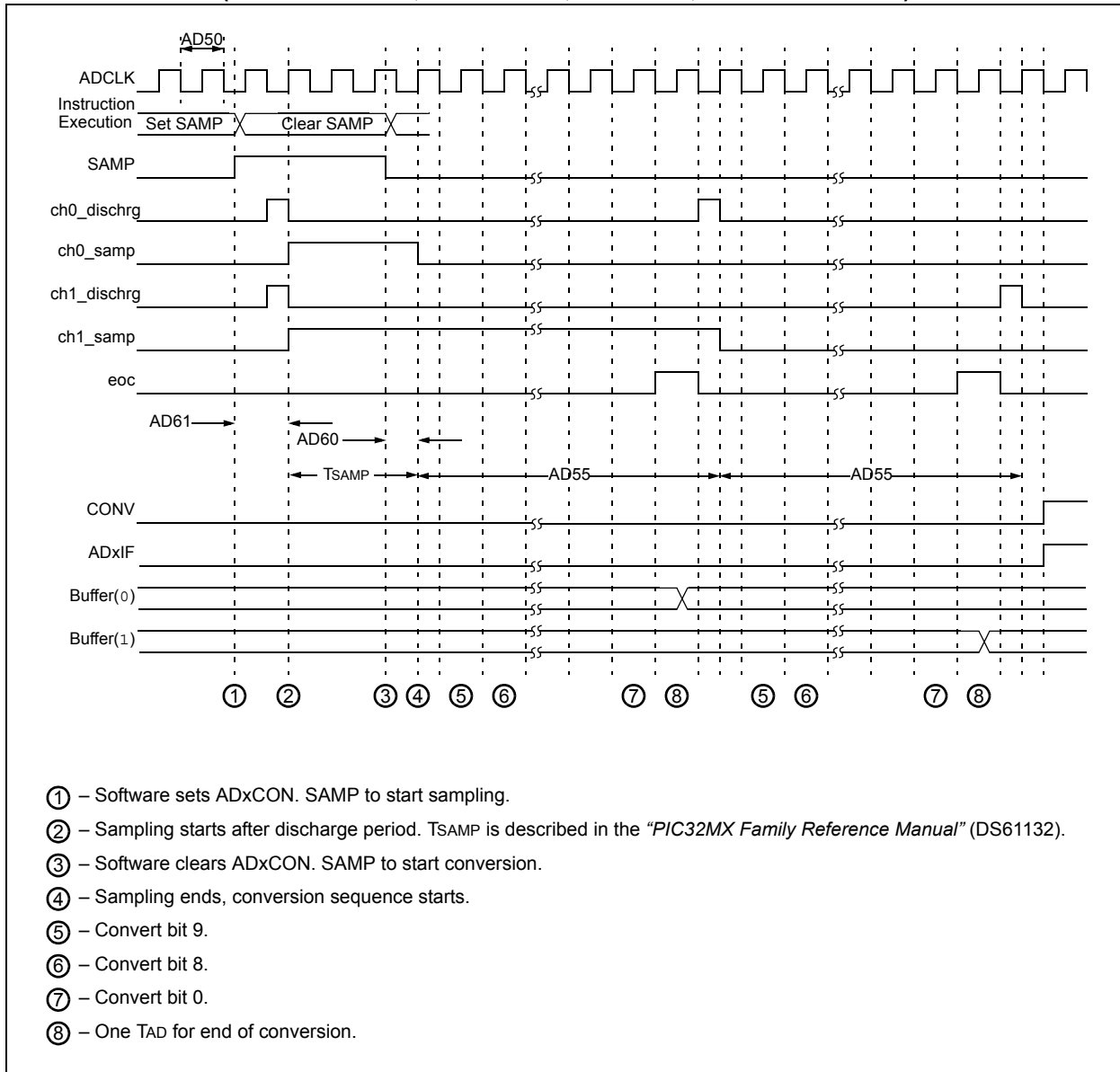
**Note 1:** These parameters are characterized, but not tested in manufacturing.

**2:** Because the sample caps will eventually lose charge, clock rates below 10 kHz can affect linearity performance, especially at elevated temperatures.

**3:** Characterized by design but not tested.

# PIC32MX5XX/6XX/7XX

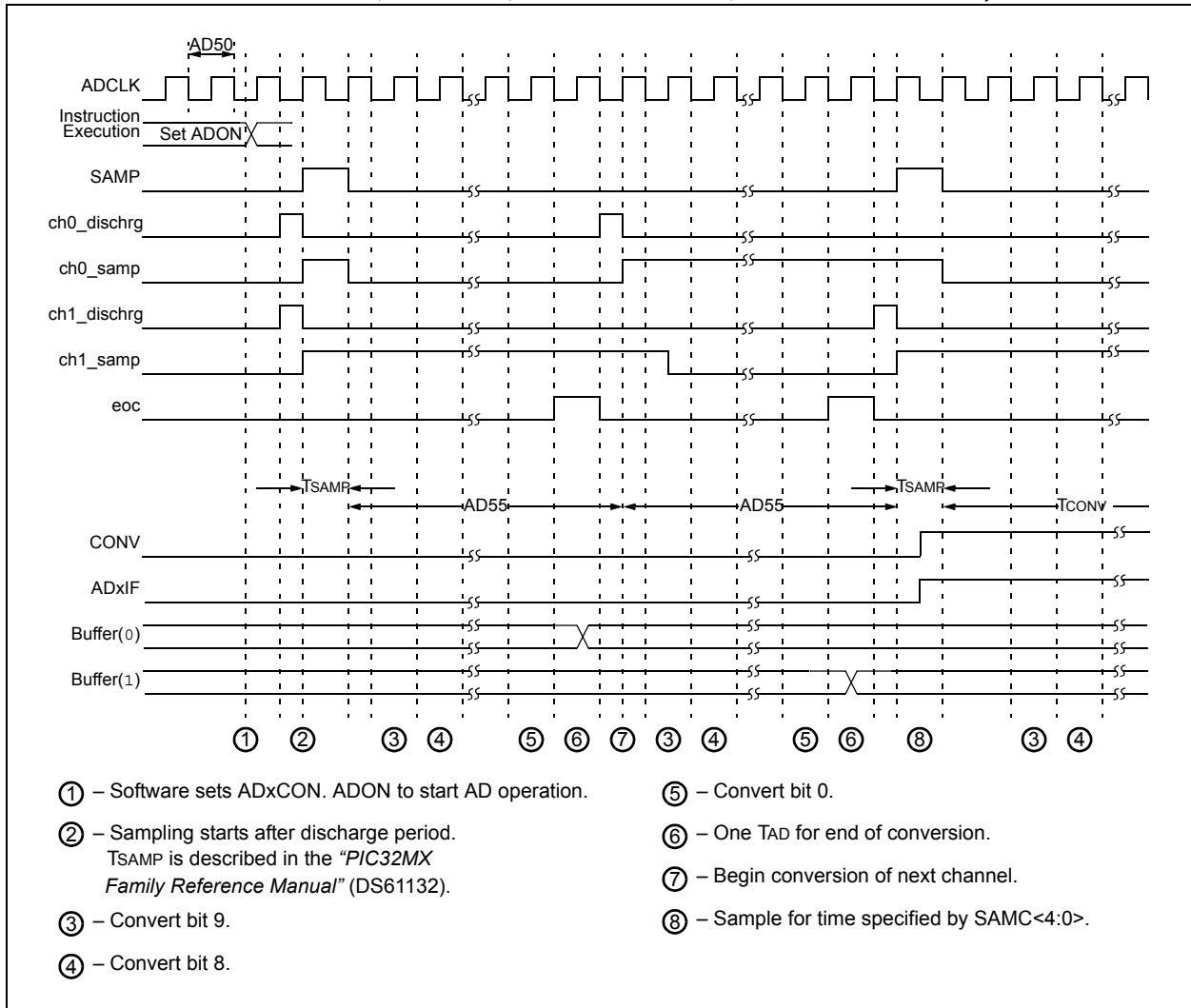
**FIGURE 31-19: A/D CONVERSION (10-BIT MODE) TIMING CHARACTERISTICS**  
 (CHPS<1:0> = 01, SIMSAM = 0, ASAM = 0, SSRC<2:0> = 000)





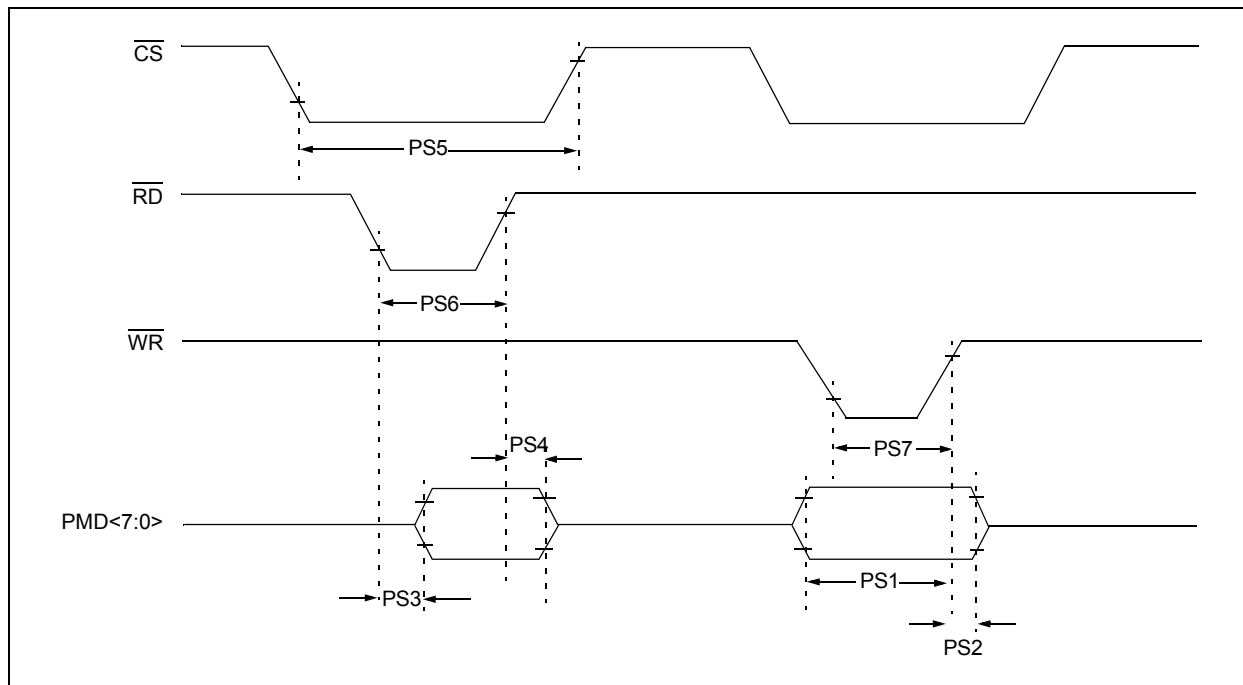
# PIC32MX5XX/6XX/7XX

**FIGURE 31-20: A/D CONVERSION (10-BIT MODE) TIMING CHARACTERISTICS (CHPS<1:0> = 01, SIMSAM = 0, ASAM = 1, SSRC<2:0> = 111, SAMC<4:0> = 00001)**



# PIC32MX5XX/6XX/7XX

**FIGURE 31-21: PARALLEL SLAVE PORT TIMING**

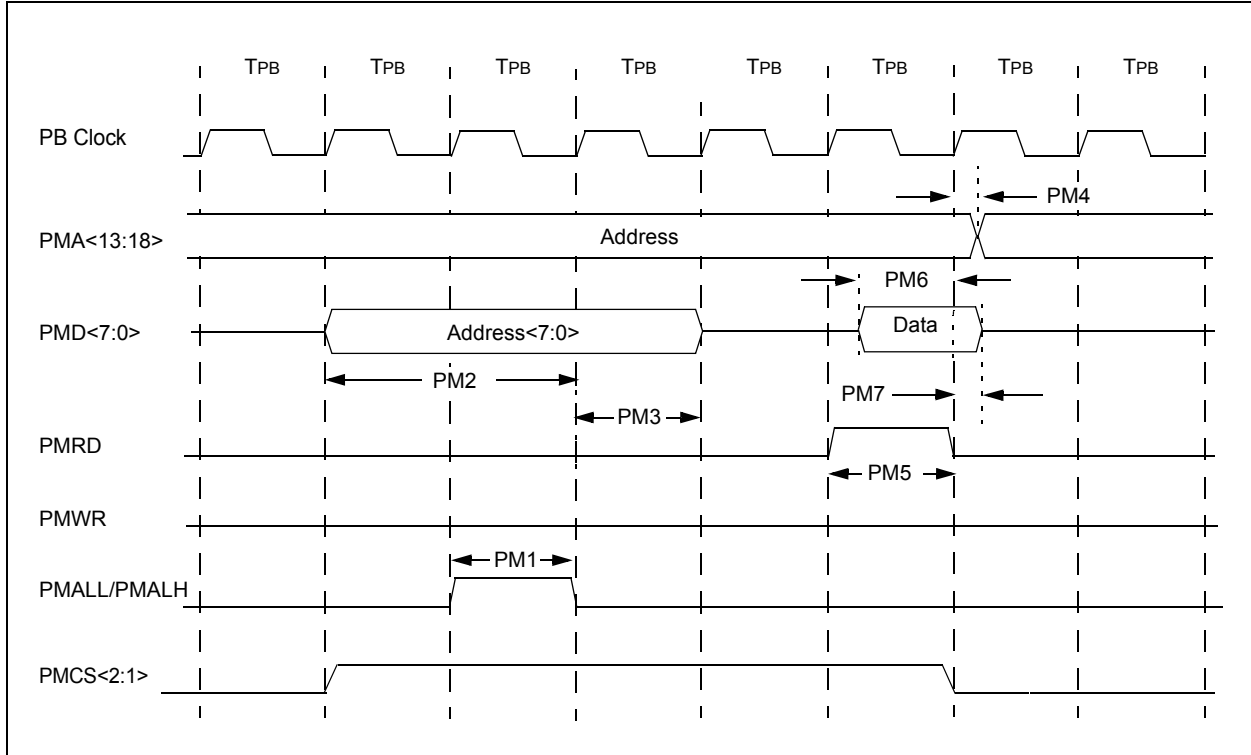


**TABLE 31-39: PARALLEL SLAVE PORT REQUIREMENTS**

AC CHARACTERISTICS			Standard Operating Conditions: 2.3V to 3.6V (unless otherwise stated) Operating temperature $-40^{\circ}\text{C} \leq T_A \leq +85^{\circ}\text{C}$ for Industrial				
Param. No.	Symbol	Characteristics <sup>(1)</sup>	Min.	Typical	Max.	Units	Conditions
PS1	TdtV2wrH	Data In Valid before $\overline{WR}$ or $\overline{CS}$ Inactive (setup time)	20	—	—	ns	—
PS2	TwrH2dtI	$\overline{WR}$ or $\overline{CS}$ Inactive to Data-In Invalid (hold time)	40	—	—	ns	—
PS3	TrdL2dtV	$\overline{RD}$ and $\overline{CS}$ Active to Data-Out Valid	—	—	60	ns	—
PS4	TrdH2dtI	$\overline{RD}$ Active or $\overline{CS}$ Inactive to Data-Out Invalid	0	—	10	ns	—
PS5	Tcs	$\overline{CS}$ Active Time	TPB + 40	—	—	ns	—
PS6	TWR	$\overline{WR}$ Active Time	TPB + 25	—	—	ns	—
PS7	TRD	$\overline{RD}$ Active Time	TPB + 25	—	—	ns	—

**Note 1:** These parameters are characterized, but not tested in manufacturing.

**FIGURE 31-22: PARALLEL MASTER PORT READ TIMING DIAGRAM**



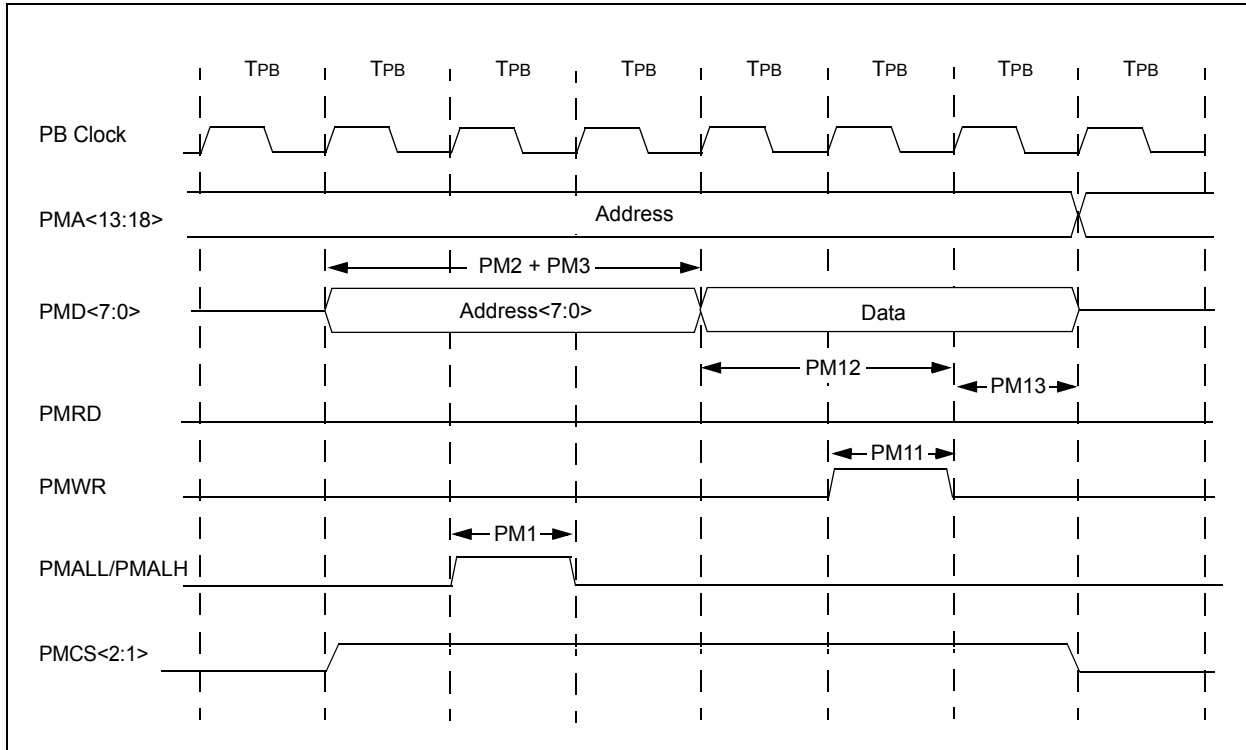
**TABLE 31-40: PARALLEL MASTER PORT READ TIMING REQUIREMENTS**

AC CHARACTERISTICS			Standard Operating Conditions: 2.3V to 3.6V (unless otherwise stated) Operating temperature $-40^{\circ}\text{C} \leq T_A \leq +85^{\circ}\text{C}$ for Industrial				
Param. No.	Symbol	Characteristics <sup>(1)</sup>	Min.	Typical	Max.	Units	Conditions
PM1	TLAT	PMALL/PMALH Pulse Width	—	1 TPB	—	—	—
PM2	TADSU	Address Out Valid to PMALL/PMALH Invalid (address setup time)	—	2 TPB	—	—	—
PM3	TADHOLD	PMALL/PMALH Invalid to Address Out Invalid (address hold time)	—	1 TPB	—	—	—
PM4	TAHOLD	PMRD Inactive to Address Out Invalid (address hold time)	5	—	—	ns	—
PM5	TRD	PMRD Pulse Width	—	1 TPB	—	—	—
PM6	TDSU	PMRD or PMENB Active to Data In Valid (data setup time)	15	—	—	ns	—
PM7	TDHOLD	PMRD or PMENB Inactive to Data In Invalid (data hold time)	—	80	—	ns	—

**Note 1:** These parameters are characterized, but not tested in manufacturing.

# PIC32MX5XX/6XX/7XX

**FIGURE 31-23: PARALLEL MASTER PORT WRITE TIMING DIAGRAM**



**TABLE 31-41: PARALLEL MASTER PORT WRITE TIMING REQUIREMENTS**

AC CHARACTERISTICS			Standard Operating Conditions: 2.3V to 3.6V (unless otherwise stated) Operating temperature $-40^{\circ}\text{C} \leq T_A \leq +85^{\circ}\text{C}$ for Industrial				
Param. No.	Symbol	Characteristics <sup>(1)</sup>	Min.	Typical	Max.	Units	Conditions
PM11	TWR	PMWR Pulse Width	—	1 TPB	—	—	—
PM12	TdVSU	Data Out Valid before PMWR or PMENB goes Inactive (data setup time)	—	2 TPB	—	—	—
PM13	TdVHOLD	PMWR or PMEMB Invalid to Data Out Invalid (data hold time)	—	1 TPB	—	—	—

**Note 1:** These parameters are characterized, but not tested in manufacturing.

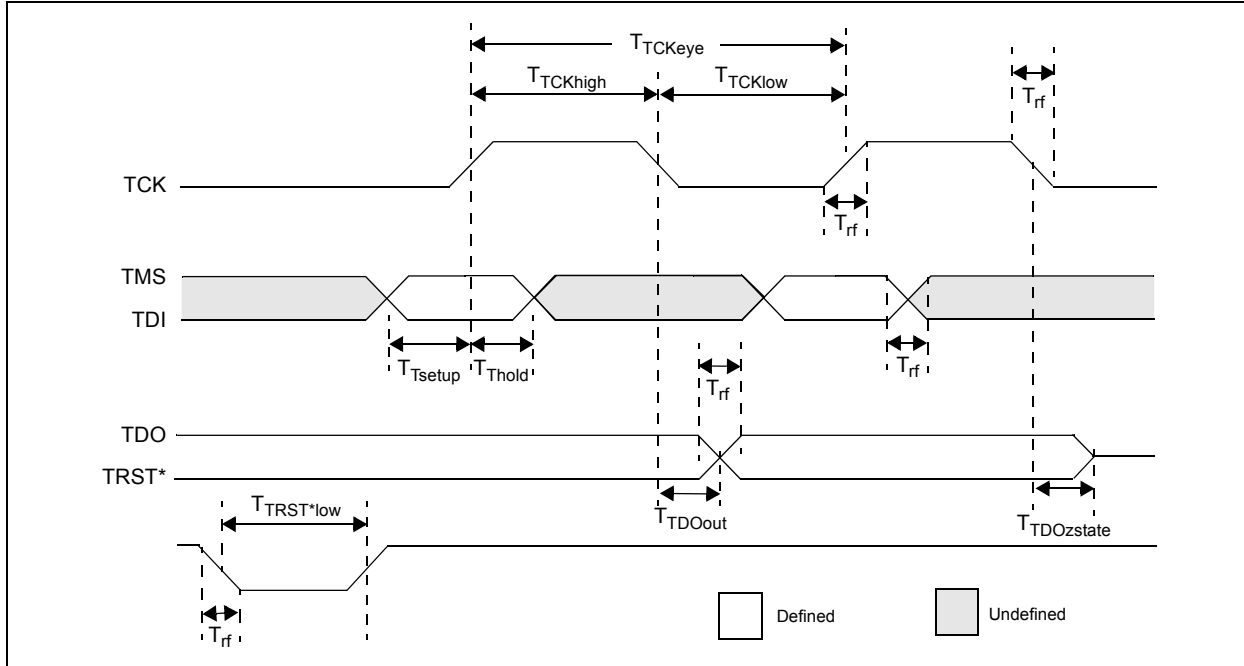
**TABLE 31-42: OTG ELECTRICAL SPECIFICATIONS**

AC CHARACTERISTICS			Standard Operating Conditions: 2.3V to 3.6V (unless otherwise stated) Operating temperature $-40^{\circ}\text{C} \leq T_A \leq +85^{\circ}\text{C}$ for Industrial				
Param. No.	Symbol	Characteristics <sup>(1)</sup>	Min.	Typical	Max.	Units	Conditions
USB313	V <sub>USB</sub>	USB Voltage	3.0	—	3.6	V	Voltage on bus must be in this range for proper USB operation
USB315	V <sub>ILUSB</sub>	Input Low Voltage for USB Buffer	—	—	0.8	V	—
USB316	V <sub>IHUSB</sub>	Input High Voltage for USB Buffer	2.0	—	—	V	—
USB318	V <sub>DIFS</sub>	Differential Input Sensitivity	—	—	0.2	V	—
USB319	V <sub>CM</sub>	Differential Common Mode Range	0.8	—	2.5	V	The difference between D+ and D- must exceed this value while V <sub>CM</sub> is met
USB320	Z <sub>OUT</sub>	Driver Output Impedance	28.0	—	44.0	Ω	—
USB321	V <sub>OL</sub>	Voltage Output Low	0.0	—	0.3	V	14.25 kΩ load connected to 3.6V
USB322	V <sub>OH</sub>	Voltage Output High	2.8	—	3.6	V	14.25 kΩ load connected to ground

**Note 1:** These parameters are characterized, but not tested in manufacturing.

# PIC32MX5XX/6XX/7XX

**FIGURE 31-24: EJTAG TIMING CHARACTERISTICS**



**TABLE 31-43: EJTAG TIMING REQUIREMENTS**

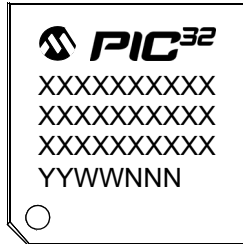
AC CHARACTERISTICS			Standard Operating Conditions: 2.3V to 3.6V (unless otherwise stated) Operating temperature $-40^{\circ}\text{C} \leq T_A \leq +85^{\circ}\text{C}$ for Industrial			
Param. No.	Symbol	Description <sup>(1)</sup>	Min.	Max.	Units	Conditions
EJ1	TTCKCYC	TCK Cycle Time	25	—	ns	—
EJ2	TTCKHIGH	TCK High Time	10	—	ns	—
EJ3	TTCKLOW	TCK Low Time	10	—	ns	—
EJ4	TTSETUP	TAP Signals Setup Time Before Rising TCK	5	—	ns	—
EJ5	TTHOLD	TAP Signals Hold Time After Rising TCK	3	—	ns	—
EJ6	TTDOOUT	TDO Output Delay Time from Falling TCK	—	5	ns	—
EJ7	TTDOZSTATE	TDO 3-State Delay Time from Falling TCK	—	5	ns	—
EJ8	TTRSTLOW	TRST Low Time	25	—	ns	—
EJ9	TRF	TAP Signals Rise/Fall Time, All Input and Output	—	—	ns	—

**Note 1:** These parameters are characterized, but not tested in manufacturing.

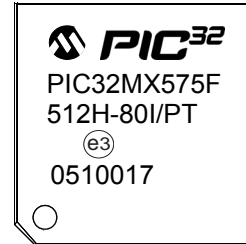
## 32.0 PACKAGING INFORMATION

### 32.1 Package Marking Information

64-Lead TQFP (10x10x1 mm)



Example



100-Lead TQFP (14x14x1 mm)



Example



100-Lead TQFP (12x12x1 mm)



Example



<b>Legend:</b>	XX...X	Customer-specific information
	Y	Year code (last digit of calendar year)
	YY	Year code (last 2 digits of calendar year)
	WW	Week code (week of January 1 is week '01')
	NNN	Alphanumeric traceability code
	*	Pb-free JEDEC designator for Matte Tin (Sn)
		This package is Pb-free. The Pb-free JEDEC designator (e3) can be found on the outer packaging for this package.

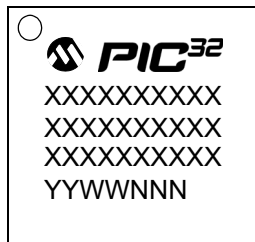
**Note:** In the event the full Microchip part number cannot be marked on one line, it will be carried over to the next line, thus limiting the number of available characters for customer-specific information.

# PIC32MX5XX/6XX/7XX

---

## 32.1 Package Marking Information (Continued)

64-Lead QFN (9x9x0.9 mm)



Example



121-Lead XBGA (10x10x1.1 mm)



Example





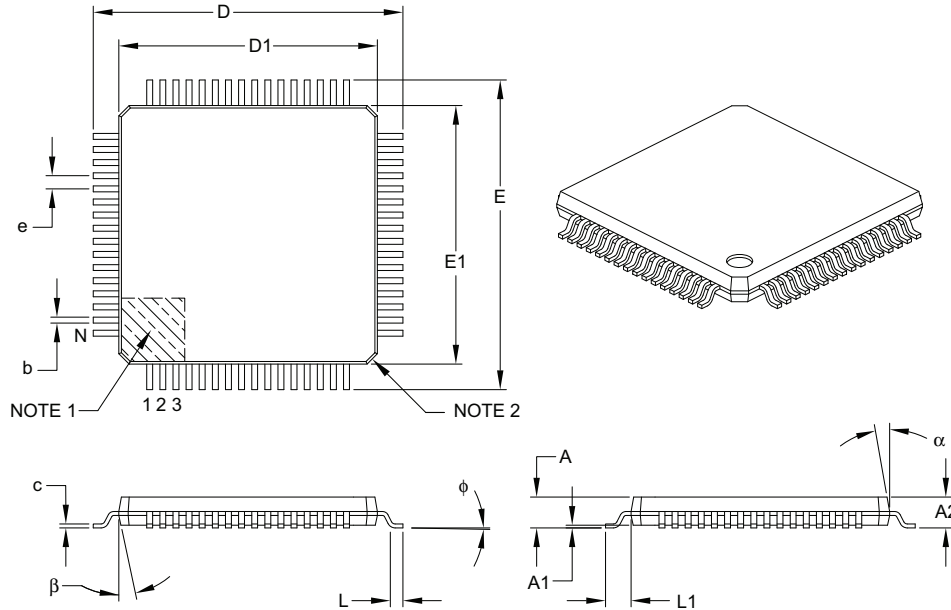
# PIC32MX5XX/6XX/7XX

## 32.2 Package Details

The following sections give the technical details of the packages.

### 64-Lead Plastic Thin Quad Flatpack (PT) – 10x10x1 mm Body, 2.00 mm [TQFP]

**Note:** For the most current package drawings, please see the Microchip Packaging Specification located at <http://www.microchip.com/packaging>



Dimension Limits	Units	MILLIMETERS		
		MIN	NOM	MAX
Number of Leads	N	64		
Lead Pitch	e	0.50 BSC		
Overall Height	A	–	–	1.20
Molded Package Thickness	A2	0.95	1.00	1.05
Standoff	A1	0.05	–	0.15
Foot Length	L	0.45	0.60	0.75
Footprint	L1	1.00 REF		
Foot Angle	$\phi$	0°	3.5°	7°
Overall Width	E	12.00 BSC		
Overall Length	D	12.00 BSC		
Molded Package Width	E1	10.00 BSC		
Molded Package Length	D1	10.00 BSC		
Lead Thickness	c	0.09	–	0.20
Lead Width	b	0.17	0.22	0.27
Mold Draft Angle Top	$\alpha$	11°	12°	13°
Mold Draft Angle Bottom	$\beta$	11°	12°	13°

**Notes:**

- Pin 1 visual index feature may vary, but must be located within the hatched area.
- Chamfers at corners are optional; size may vary.
- Dimensions D1 and E1 do not include mold flash or protrusions. Mold flash or protrusions shall not exceed 0.25 mm per side.
- Dimensioning and tolerancing per ASME Y14.5M.

BSC: Basic Dimension. Theoretically exact value shown without tolerances.

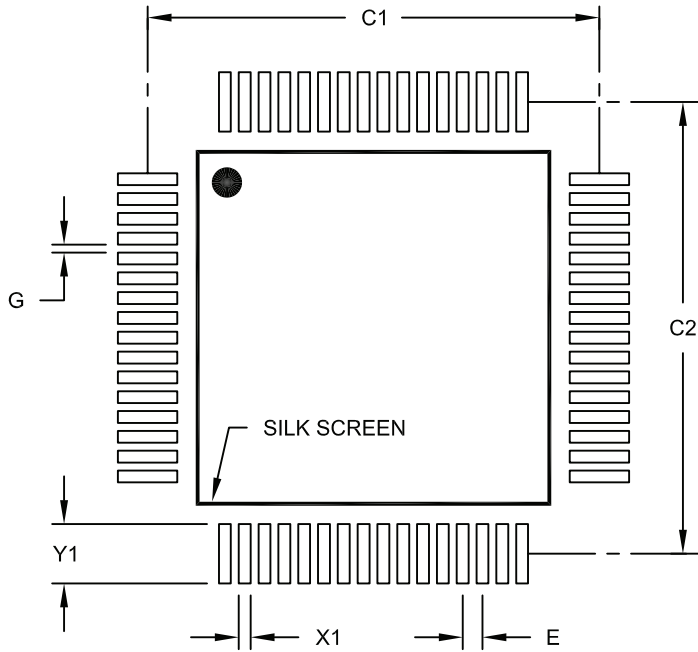
REF: Reference Dimension, usually without tolerance, for information purposes only.

Microchip Technology Drawing C04-085B

# PIC32MX5XX/6XX/7XX

## 64-Lead Plastic Thin Quad Flatpack (PT) – 10x10x1 mm Body, 2.00 mm [TQFP]

**Note:** For the most current package drawings, please see the Microchip Packaging Specification located at <http://www.microchip.com/packaging>



RECOMMENDED LAND PATTERN

Dimension Limits	Units	MILLIMETERS		
		MIN	NOM	MAX
Contact Pitch	E	0.50 BSC		
Contact Pad Spacing	C1		11.40	
Contact Pad Spacing	C2		11.40	
Contact Pad Width (X64)	X1			0.30
Contact Pad Length (X64)	Y1			1.50
Distance Between Pads	G	0.20		

Notes:

1. Dimensioning and tolerancing per ASME Y14.5M

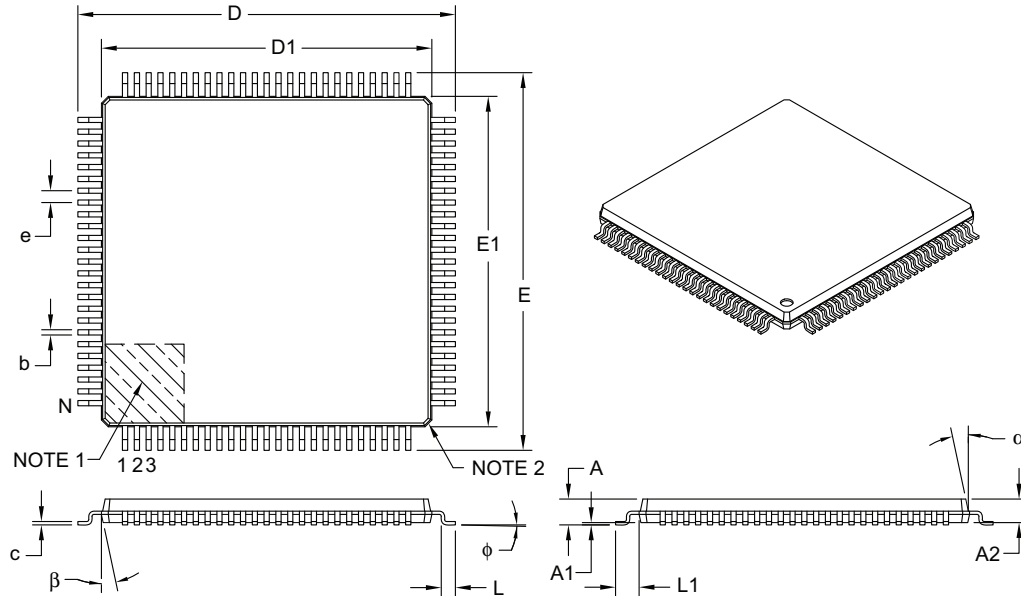
BSC: Basic Dimension. Theoretically exact value shown without tolerances.

Microchip Technology Drawing No. C04-2085A

# PIC32MX5XX/6XX/7XX

## 100-Lead Plastic Thin Quad Flatpack (PF) – 14x14x1 mm Body, 2.00 mm [TQFP]

**Note:** For the most current package drawings, please see the Microchip Packaging Specification located at <http://www.microchip.com/packaging>



Dimension Limits	Units	MILLIMETERS		
		MIN	NOM	MAX
Number of Leads	N	100		
Lead Pitch	e	0.50 BSC		
Overall Height	A	–	–	1.20
Molded Package Thickness	A2	0.95	1.00	1.05
Standoff	A1	0.05	–	0.15
Foot Length	L	0.45	0.60	0.75
Footprint	L1	1.00 REF		
Foot Angle	φ	0°	3.5°	7°
Overall Width	E	16.00 BSC		
Overall Length	D	16.00 BSC		
Molded Package Width	E1	14.00 BSC		
Molded Package Length	D1	14.00 BSC		
Lead Thickness	c	0.09	–	0.20
Lead Width	b	0.17	0.22	0.27
Mold Draft Angle Top	α	11°	12°	13°
Mold Draft Angle Bottom	β	11°	12°	13°

**Notes:**

1. Pin 1 visual index feature may vary, but must be located within the hatched area.
2. Chamfers at corners are optional; size may vary.
3. Dimensions D1 and E1 do not include mold flash or protrusions. Mold flash or protrusions shall not exceed 0.25 mm per side.
4. Dimensioning and tolerancing per ASME Y14.5M.

BSC: Basic Dimension. Theoretically exact value shown without tolerances.

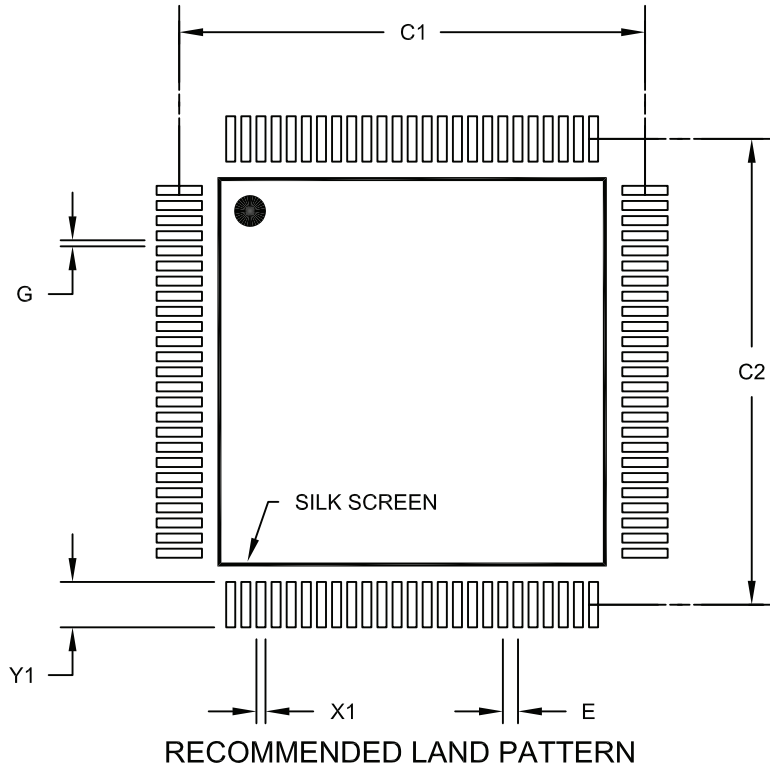
REF: Reference Dimension, usually without tolerance, for information purposes only.

Microchip Technology Drawing C04-110B

# PIC32MX5XX/6XX/7XX

## 100-Lead Plastic Thin Quad Flatpack (PF) – 14x14x1 mm Body, 2.00 mm [TQFP]

**Note:** For the most current package drawings, please see the Microchip Packaging Specification located at <http://www.microchip.com/packaging>



Dimension Limits	Units	MILLIMETERS		
		MIN	NOM	MAX
Contact Pitch	E	0.50 BSC		
Contact Pad Spacing	C1		15.40	
Contact Pad Spacing	C2		15.40	
Contact Pad Width (X100)	X1			0.30
Contact Pad Length (X100)	Y1			1.50
Distance Between Pads	G	0.20		

**Notes:**

1. Dimensioning and tolerancing per ASME Y14.5M

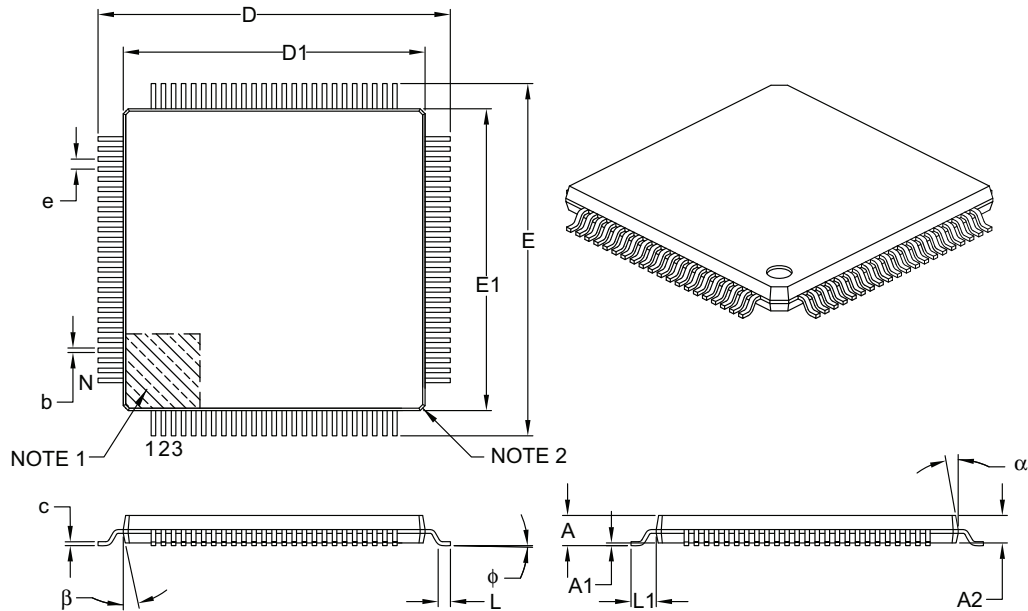
BSC: Basic Dimension. Theoretically exact value shown without tolerances.

Microchip Technology Drawing No. C04-2110A

# PIC32MX5XX/6XX/7XX

## 100-Lead Plastic Thin Quad Flatpack (PT) – 12x12x1 mm Body, 2.00 mm [TQFP]

**Note:** For the most current package drawings, please see the Microchip Packaging Specification located at <http://www.microchip.com/packaging>



Dimension Limits	Units	MILLIMETERS		
		MIN	NOM	MAX
Number of Leads	N	100		
Lead Pitch	e	0.40 BSC		
Overall Height	A	–	–	1.20
Molded Package Thickness	A2	0.95	1.00	1.05
Standoff	A1	0.05	–	0.15
Foot Length	L	0.45	0.60	0.75
Footprint	L1	1.00 REF		
Foot Angle	φ	0°	3.5°	7°
Overall Width	E	14.00 BSC		
Overall Length	D	14.00 BSC		
Molded Package Width	E1	12.00 BSC		
Molded Package Length	D1	12.00 BSC		
Lead Thickness	c	0.09	–	0.20
Lead Width	b	0.13	0.18	0.23
Mold Draft Angle Top	α	11°	12°	13°
Mold Draft Angle Bottom	β	11°	12°	13°

### Notes:

- Pin 1 visual index feature may vary, but must be located within the hatched area.
- Chamfers at corners are optional; size may vary.
- Dimensions D1 and E1 do not include mold flash or protrusions. Mold flash or protrusions shall not exceed 0.25 mm per side.
- Dimensioning and tolerancing per ASME Y14.5M.

BSC: Basic Dimension. Theoretically exact value shown without tolerances.

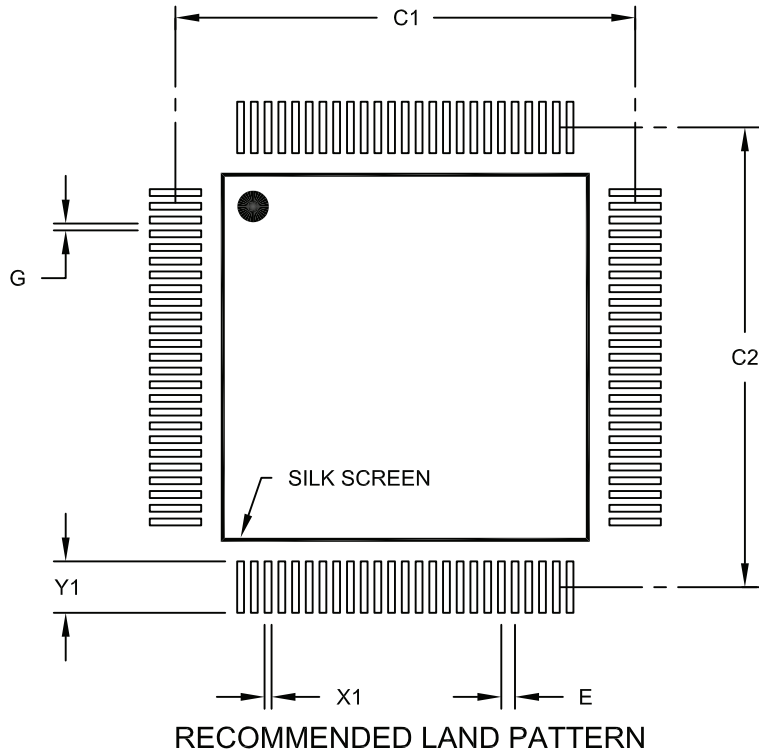
REF: Reference Dimension, usually without tolerance, for information purposes only.

Microchip Technology Drawing C04-100B

# PIC32MX5XX/6XX/7XX

## 100-Lead Plastic Thin Quad Flatpack (PT) – 12x12x1 mm Body, 2.00 mm [TQFP]

**Note:** For the most current package drawings, please see the Microchip Packaging Specification located at <http://www.microchip.com/packageing>



Dimension Limits	Units	MILLIMETERS		
		MIN	NOM	MAX
Contact Pitch	E	0.40 BSC		
Contact Pad Spacing	C1		13.40	
Contact Pad Spacing	C2		13.40	
Contact Pad Width (X100)	X1			0.20
Contact Pad Length (X100)	Y1			1.50
Distance Between Pads	G	0.20		

**Notes:**

1. Dimensioning and tolerancing per ASME Y14.5M

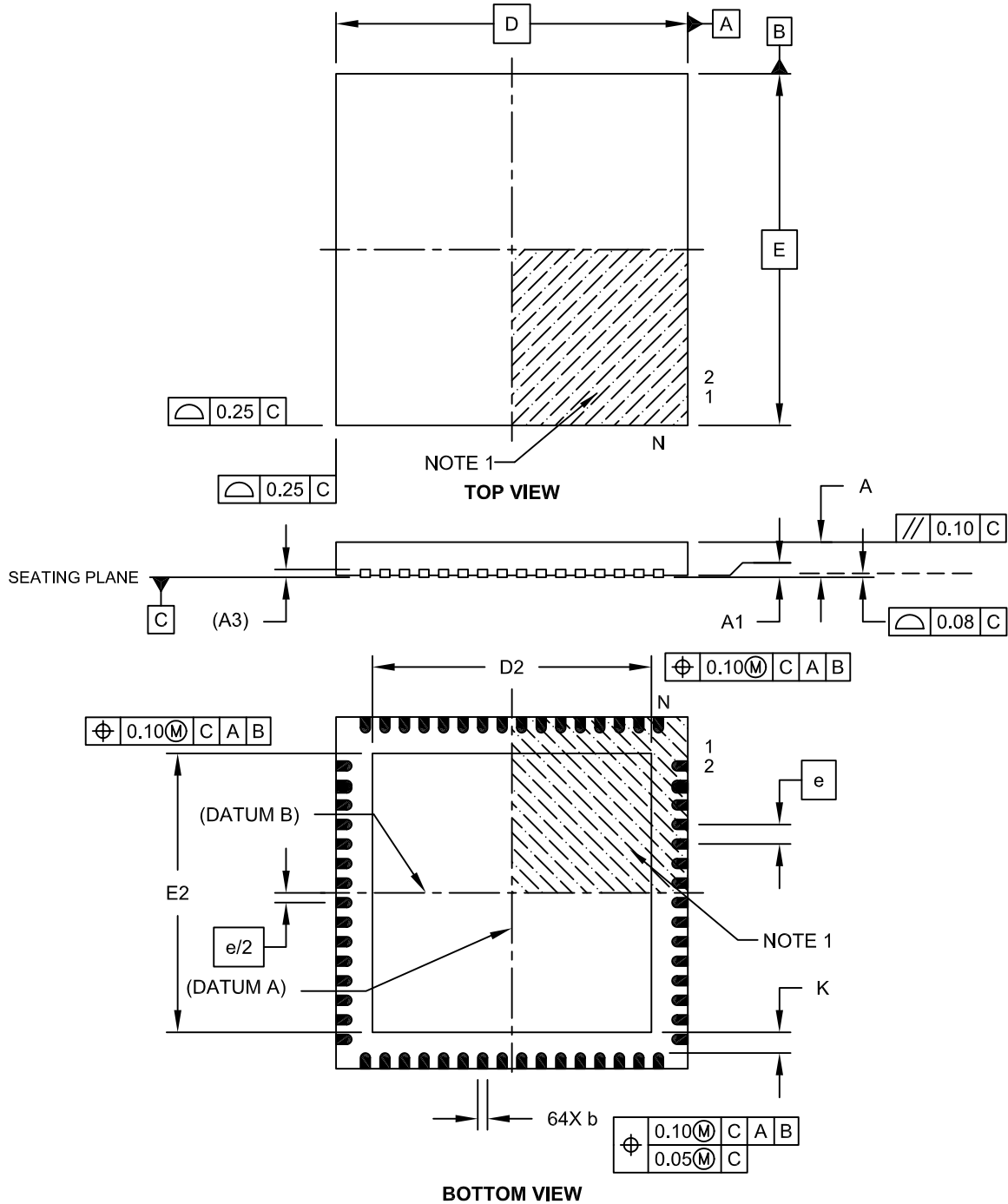
BSC: Basic Dimension. Theoretically exact value shown without tolerances.

Microchip Technology Drawing No. C04-2100A

# PIC32MX5XX/6XX/7XX

## 64-Lead Plastic Quad Flat, No Lead Package (MR) – 9x9x0.9 mm Body [QFN]

**Note:** For the most current package drawings, please see the Microchip Packaging Specification located at <http://www.microchip.com/packaging>

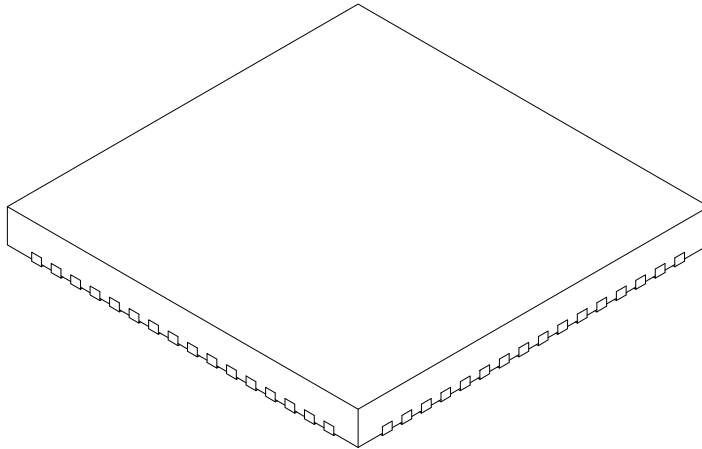


Microchip Technology Drawing C04-149B Sheet 1 of 2

# PIC32MX5XX/6XX/7XX

## 64-Lead Plastic Quad Flat, No Lead Package (MR) – 9x9x0.9 mm Body [QFN]

**Note:** For the most current package drawings, please see the Microchip Packaging Specification located at <http://www.microchip.com/packageing>



Dimension Limits	Units	MILLIMETERS		
		MIN	NOM	MAX
Number of Pins	N	64		
Pitch	e	0.50 BSC		
Overall Height	A	0.80	0.90	1.00
Standoff	A1	0.00	0.02	0.05
Contact Thickness	A3	0.20 REF		
Overall Width	E	9.00 BSC		
Exposed Pad Width	E2	7.05	7.15	7.50
Overall Length	D	9.00 BSC		
Exposed Pad Length	D2	7.05	7.15	7.50
Contact Width	b	0.18	0.25	0.30
Contact Length	L	0.30	0.40	0.50
Contact-to-Exposed Pad	K	0.20	-	-

**Notes:**

1. Pin 1 visual index feature may vary, but must be located within the hatched area.
2. Package is saw singulated.
3. Dimensioning and tolerancing per ASME Y14.5M.  
BSC: Basic Dimension. Theoretically exact value shown without tolerances.  
REF: Reference Dimension, usually without tolerance, for information purposes only.

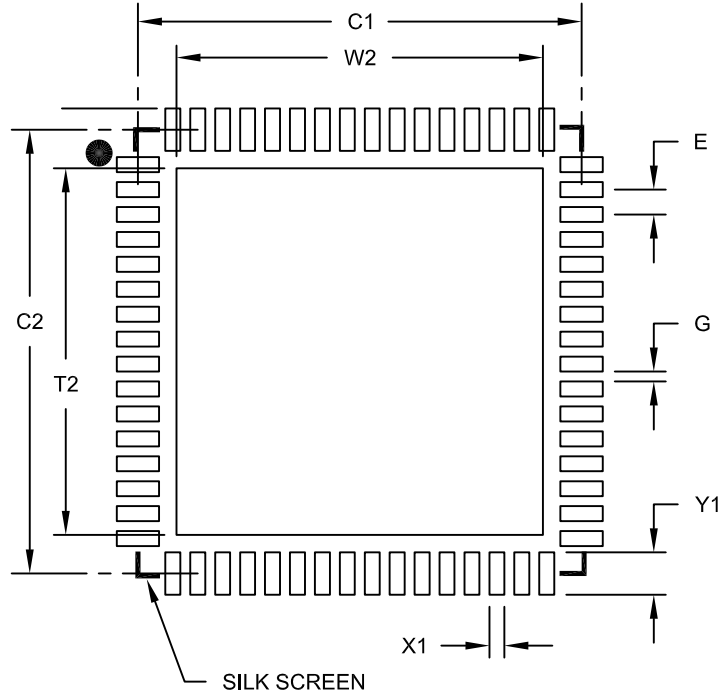
Microchip Technology Drawing C04-149B Sheet 2 of 2



# PIC32MX5XX/6XX/7XX

64-Lead Plastic Quad Flat, No Lead Package (MR) – 9x9x0.9 mm Body [QFN]  
With 0.40 mm Contact Length

**Note:** For the most current package drawings, please see the Microchip Packaging Specification located at <http://www.microchip.com/packaging>



RECOMMENDED LAND PATTERN

Dimension Limits	Units	MILLIMETERS		
		MIN	NOM	MAX
Contact Pitch	E	0.50 BSC		
Optional Center Pad Width	W2			7.35
Optional Center Pad Length	T2			7.35
Contact Pad Spacing	C1		8.90	
Contact Pad Spacing	C2		8.90	
Contact Pad Width (X64)	X1			0.30
Contact Pad Length (X64)	Y1			0.85
Distance Between Pads	G	0.20		

Notes:

1. Dimensioning and tolerancing per ASME Y14.5M

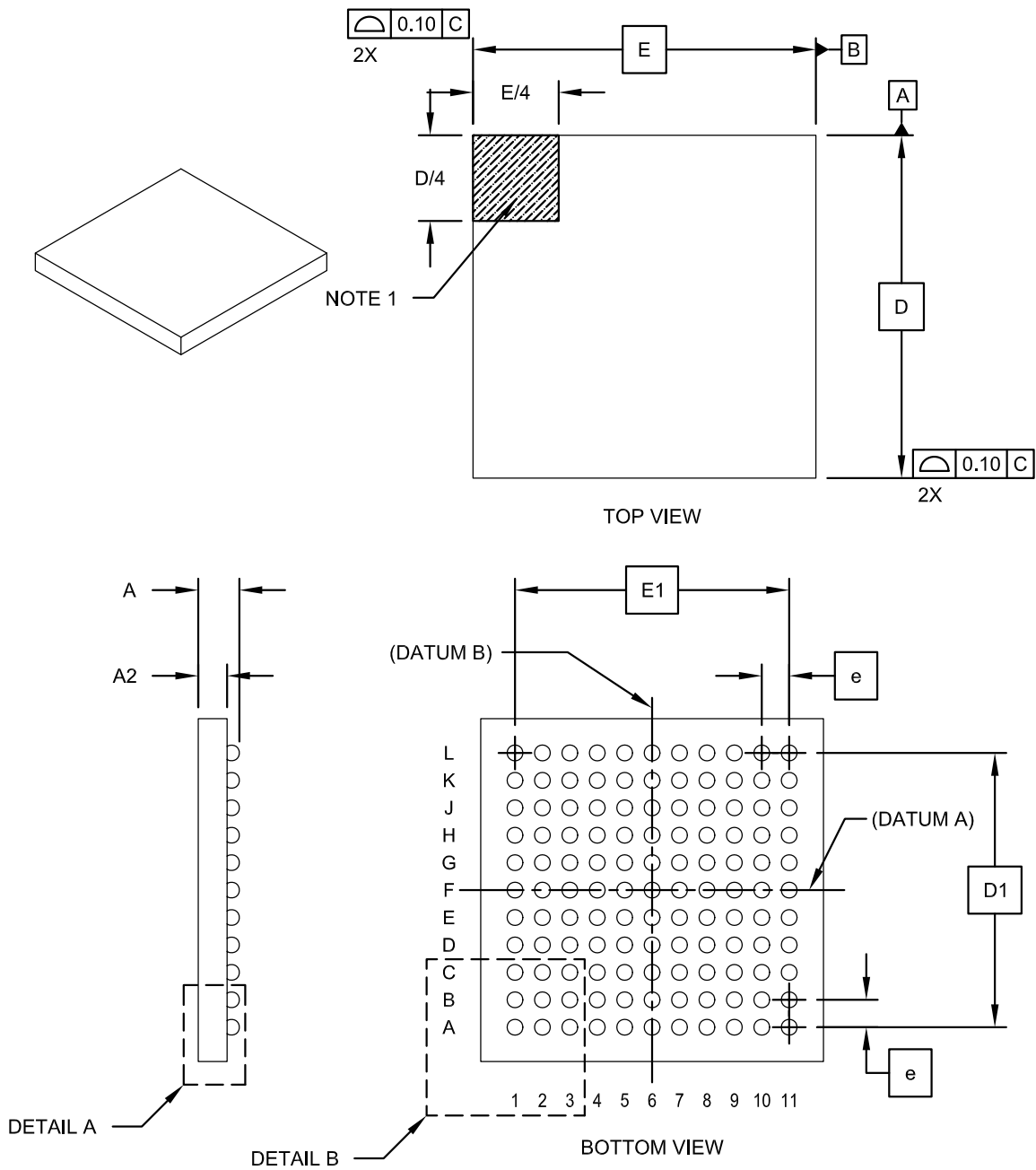
BSC: Basic Dimension. Theoretically exact value shown without tolerances.

Microchip Technology Drawing No. C04-2149A

# PIC32MX5XX/6XX/7XX

## 121-Lead Plastic Thin Profile Ball Grid Array (BG) - 10x10x1.10 mm Body [XBGA]

**Note:** For the most current package drawings, please see the Microchip Packaging Specification located at <http://www.microchip.com/packaging>

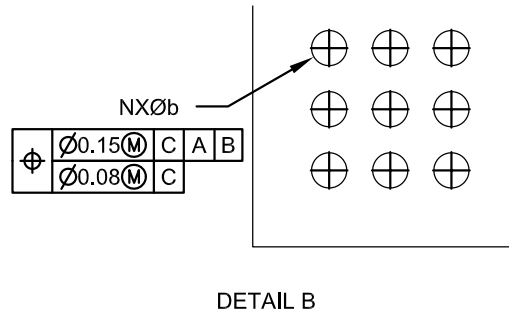
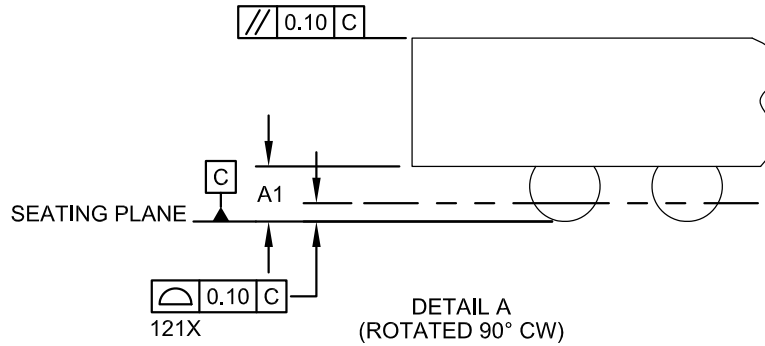


Microchip Technology Drawing C04-148A Sheet 1 of 2

# PIC32MX5XX/6XX/7XX

## 121-Lead Plastic Thin Profile Ball Grid Array (BG) - 10x10x1.10 mm Body [XBGA]

**Note:** For the most current package drawings, please see the Microchip Packaging Specification located at <http://www.microchip.com/packaging>



Dimension Limits	Units	MILLIMETERS		
		MIN	NOM	MAX
Number of Contacts	N	121		
Contact Pitch	e	0.80 BSC		
Overall Height	A	1.00	1.10	1.20
Standoff	A1	0.25	0.30	0.35
Molded Package Thickness	A2	0.55	0.60	0.65
Overall Width	E	10.00 BSC		
Array Width	E1	8.00 BSC		
Overall Length	D	10.00 BSC		
Array Length	D1	8.00 BSC		
Contact Diameter	b	0.40 TYP		

**Notes:**

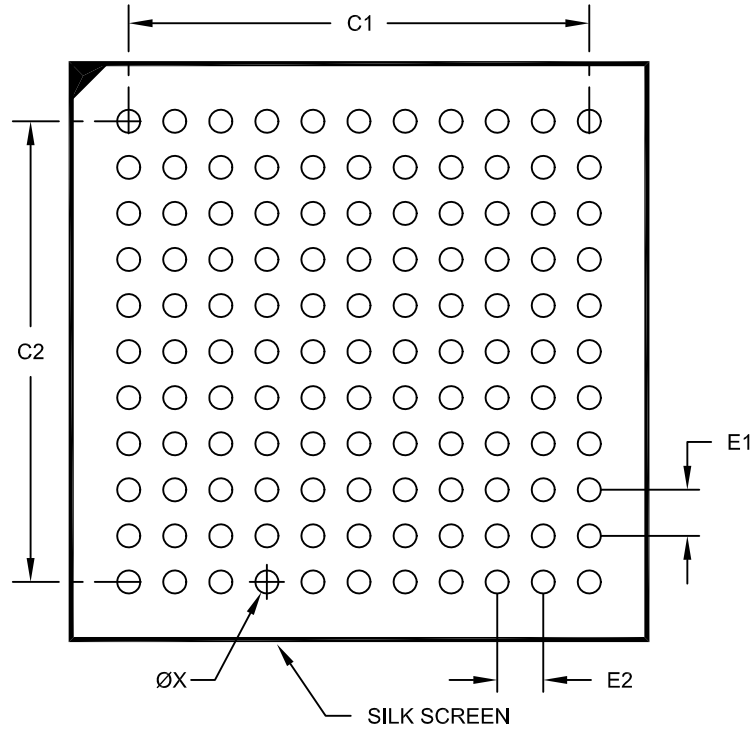
- Pin 1 visual index feature may vary, but must be located within the hatched area.
- Dimensioning and tolerancing per ASME Y14.5M.  
BSC: Basic Dimension. Theoretically exact value shown without tolerances.  
REF: Reference Dimension, usually without tolerance, for information purposes only.
- The outer rows and columns of balls are located with respect to datums A and B.

Microchip Technology Drawing C04-148 Rev A Sheet 2 of 2

# PIC32MX5XX/6XX/7XX

121-Lead Plastic Thin Profile Ball Grid Array (BG) - 10x10x1.10 mm Body [XBGA]

**Note:** For the most current package drawings, please see the Microchip Packaging Specification located at <http://www.microchip.com/packaging>



RECOMMENDED LAND PATTERN

		Units	MILLIMETERS		
Dimension Limits			MIN	NOM	MAX
Contact Pitch	E1		0.80 BSC		
Contact Pitch	E2		0.80 BSC		
Contact Pad Spacing	C1			8.00	
Contact Pad Spacing	C2			8.00	
Contact Pad Diameter (X121)	X				0.40

Notes:

1. Dimensioning and tolerancing per ASME Y14.5M

BSC: Basic Dimension. Theoretically exact value shown without tolerances.

Microchip Technology Drawing No. C04-2148A

## APPENDIX A: MIGRATING FROM PIC32MX3XX/4XX TO PIC32MX5XX/6XX/7XX DEVICES

This appendix provides an overview of considerations for migrating from PIC32MX3XX/4XX devices to the PIC32MX5XX/6XX/7XX family of devices. The code developed for the PIC32MX3XX/4XX devices can be ported to the PIC32MX5XX/6XX/7XX devices after making the appropriate changes outlined below.

### A.1 DMA

PIC32MX5XX/6XX/7XX devices do not support stopping DMA transfers in Idle mode.

### A.2 Interrupts

PIC32MX5XX/6XX/7XX devices have persistent interrupts for some of the peripheral modules. This means that the interrupt condition for these peripherals must be cleared before the interrupt flag can be cleared.

For example, to clear a UART receive interrupt, the user application must first read the UART Receive register to clear the interrupt condition and then clear the associated UxIF flag to clear the pending UART interrupt. In other words, the UxIF flag cannot be cleared by software until the UART Receive register is read.

Table A-1 outlines the peripherals and associated interrupts that are implemented differently on PIC32MX5XX/6XX/7XX versus PIC32MX3XX/4XX devices.

In addition, on the SPI module, the IRQ numbers for the receive done interrupts were changed from 25 to 24 and the transfer done interrupts were changed from 24 to 25.

### A.3 Pin Assignments

PIC32MX5XX/6XX/7XX devices have the same pin assignment for peripherals as PIC32MX4XX devices with the following exceptions:

- Pins associated with the UART1 and UART2 modules on PIC32MX4XX devices are now associated with the UART1A and UART3A modules, respectively on PIC32MX5XX/6XX/7XX devices
- Pins associated with the SPI2 module on PIC32MX4XX devices are now associated with the SPI2A module on PIC32MX5XX/6XX/7XX devices

**TABLE A-1: PIC32MX3XX/4XX vs. PIC32MX5XX/6XX/7XX INTERRUPT IMPLEMENTATION DIFFERENCES**

Module	Interrupt Implementation
Input Capture	To clear an interrupt source, read the Buffer Result (ICxBUF) register to obtain the number of capture results in the buffer that are below the interrupt threshold (specified by ICI<1:0> bits).
SPI	Receive and transmit interrupts are controlled by the SRXISEL<1:0> and STXISEL<1:0> bits, respectively. To clear an interrupt source, data must be written to, or read from, the SPIxBUF register to obtain the number of data to receive/transmit below the level specified by the SRXISEL<1:0> and STXISEL<1:0> bits.
UART	TX interrupt will be generated as soon as the UART module is enabled. Receive and transmit interrupts are controlled by the URXISEL<1:0> and UTXISEL<1:0> bits, respectively. To clear an interrupt source, data must be read from, or written to, the UxRXREG or UxTXREG registers to obtain the number of data to receive/transmit below the level specified by the URXISEL<1:0> and UTXISEL<1:0> bits.
ADC	All samples must be read from the result registers (ADC1BUFx) to clear the interrupt source.
PMP	To clear an interrupt source, read the Parallel Master Port Data Input/Output (PMDIN/PMDOUT) register.

# PIC32MX5XX/6XX/7XX

## APPENDIX B: REVISION HISTORY

### Revision A (August 2009)

This is the initial released version of this document.

### Revision B (November 2009)

The revision includes the following global update:

- Added Note 2 to the shaded table that appears at the beginning of each chapter. This new note provides information regarding the availability of registers and their associated bits.

Other major changes are referenced by their respective chapter/section in Table B-1.

**TABLE B-1: MAJOR SECTION UPDATES**

Section Name	Update Description
<b>“High-Performance, USB, CAN and Ethernet 32-bit Flash Microcontrollers”</b>	<p>Added the following devices:</p> <ul style="list-style-type: none"><li>- PIC32MX575F256L</li><li>- PIC32MX695F512L</li><li>- PIC32MX695F512H</li></ul> <p>The 100-pin TQFP pin diagrams have been updated to reflect the current pin name locations (see the <b>“Pin Diagrams”</b> section).</p> <p>Added the 121-pin Ball Grid Array (XBGA) pin diagram.</p> <p>Updated Table 1: “PIC32MX USB and CAN – Features”</p> <p>Added the following tables:</p> <ul style="list-style-type: none"><li>- Table 4: “Pin Names: PIC32MX575F256L and PIC32MX575F512L Devices”</li><li>- Table 5: “Pin Names: PIC32MX675F256L, PIC32MX675F512L and PIC32MX695F512L Devices”</li><li>- Table 6: “Pin Names: PIC32MX775F256L, PIC32MX775F512L and PIC32MX795F512L Devices”</li></ul> <p>Updated the following pins as 5V tolerant:</p> <ul style="list-style-type: none"><li>- 64-pin QFN: Pin 36 (D-/RG3) and Pin 37 (D+/RG2)</li><li>- 64-pin TQFP: Pin 36 (D-/RG3) and Pin 37 (D+/RG2)</li><li>- 100-pin TQFP: Pin 56 (D-/RG3) and Pin 57 (D+/RG2)</li></ul>
<b>Section 2.0 “Guidelines for Getting Started with 32-bit Microcontrollers”</b>	<p>Removed the last sentence of <b>Section 2.3.1 “Internal Regulator Mode”</b>.</p> <p>Removed Section 2.3.2 “External Regulator Mode”</p>

# PIC32MX5XX/6XX/7XX

**TABLE B-1: MAJOR SECTION UPDATES (CONTINUED)**

Section Name	Update Description
<b>Section 4.0 “Memory Organization”</b>	<p>Updated all register tables to include the Virtual Address and All Resets columns.</p> <p>Updated the title of Figure 4-1 to include the PIC32MX575F256L device.</p> <p>Updated the title of Figure 4-3 to include the PIC32MX695F512L and PIC32MX695F512H devices. Also changed PIC32MX795F512L to PIC32MX795F512H.</p> <p>Updated the title of Table 4-3 to include the PIC32MX695F512H device.</p> <p>Updated the title of Table 4-5 to include the PIC32MX575F256L device.</p> <p>Updated the title of Table 4-6 to include the PIC32MX695F512L device.</p> <p>Reversed the order of Table 4-11 and Table 4-12.</p> <p>Reversed the order of Table 4-14 and Table 4-15.</p> <p>Updated the title of Table 4-15 to include the PIC32MX575F256L and PIC32MX695F512L devices.</p> <p>Updated the title of Table 4-45 to include the PIC32MX575F256L device.</p> <p>Updated the title of Table 4-47 to include the PIC32MX695F512H and PIC32MX695F512L devices.</p>
<b>Section 12.0 “I/O Ports”</b>	<p>Updated the second paragraph of <b>Section 12.1.2 “Digital Inputs”</b> and removed Table 12-1.</p>
<b>Section 22.0 “10-bit Analog-to-Digital Converter (ADC)”</b>	<p>Updated the ADC Conversion Clock Period Block Diagram (see Figure 22-2).</p>
<b>Section 28.0 “Special Features”</b>	<p>Removed references to the ENVREG pin in <b>Section 28.3 “On-Chip Voltage Regulator”</b>.</p> <p>Updated the first sentence of <b>Section 28.3.1 “On-Chip Regulator and POR”</b> and <b>Section 28.3.2 “On-Chip Regulator and BOR”</b>.</p> <p>Updated the Connections for the On-Chip Regulator (see Figure 28-2).</p>
<b>Section 31.0 “Electrical Characteristics”</b>	<p>Updated the Absolute Maximum Ratings and added Note 3.</p> <p>Added Thermal Packaging Characteristics for the 121-pin XBGA package (see Table 31-3).</p> <p>Updated the Operating Current (IDD) DC Characteristics (see Table 31-5).</p> <p>Updated the Idle Current (IIDL) DC Characteristics (see Table 31-6).</p> <p>Updated the Power-Down Current (IPD) DC Characteristics (see Table 31-7).</p> <p>Removed Note 1 from the Program Flash Memory Wait State Characteristics (see Table 31-11).</p> <p>Updated the SPIx Module Slave Mode (CKE = 1) Timing Characteristics, changing SP52 to SP35 between the MSb and Bit 14 on SDOx (see Figure 31-13).</p>
<b>Section 32.0 “Packaging Information”</b>	<p>Added the 121-pin XBGA package marking information and package details.</p>
<b>“Product Identification System”</b>	<p>Added the definition for BG (121-lead 10x10x1.1 mm, XBGA).</p> <p>Added the definition for Speed.</p>

# PIC32MX5XX/6XX/7XX

## Revision C (February 2010)

The revision includes the following updates, as described in Table B-2:

**TABLE B-2: MAJOR SECTION UPDATES**

Section Name	Update Description																								
<b>“High-Performance, USB, CAN and Ethernet 32-bit Flash Microcontrollers”</b>	<p>Added the following devices:</p> <ul style="list-style-type: none"> <li>• PIC32MX675F256H</li> <li>• PIC32MX775F256H</li> <li>• PIC32MX775F512H</li> <li>• PIC32MX675F256L</li> <li>• PIC32MX775F256L</li> <li>• PIC32MX775F512L</li> </ul> <p>Added the following pins:</p> <ul style="list-style-type: none"> <li>• EREFCLK</li> <li>• ECRSDV</li> <li>• AEREFCLK</li> <li>• AECRSDV</li> </ul> <p>Added the EREFCLK and ECRSDV pins to Table 5 and Table 6.</p>																								
<b>Section 1.0 “Device Overview”</b>	<p>Updated the pin number pinout I/O descriptions for the following pin names in Table 1-1:</p> <table border="0" style="width: 100%;"> <tr> <td>• SCL1A</td> <td>• TMS</td> <td>• C1IN-</td> </tr> <tr> <td>• SDA1A</td> <td>• TCK</td> <td>• C1IN+</td> </tr> <tr> <td>• SCL2</td> <td>• TDI</td> <td>• C1OUT</td> </tr> <tr> <td>• SDA2</td> <td>• TDO</td> <td>• C2IN-</td> </tr> <tr> <td>• SCL2A</td> <td>• RTCC</td> <td>• C2IN+</td> </tr> <tr> <td>• SDA2A</td> <td>• CVREF-</td> <td>• C2OUT</td> </tr> <tr> <td>• SCL3A</td> <td>• CVREF+</td> <td>• PMA0</td> </tr> <tr> <td>• SDA3A</td> <td>• CVREFOUT</td> <td>• PMA1</td> </tr> </table> <p>Added the following pins to the Pinout I/O Descriptions table (Table 1-1):</p> <ul style="list-style-type: none"> <li>• EREFCLK</li> <li>• ECRSDV</li> <li>• AEREFCLK</li> <li>• AECRSDV</li> </ul>	• SCL1A	• TMS	• C1IN-	• SDA1A	• TCK	• C1IN+	• SCL2	• TDI	• C1OUT	• SDA2	• TDO	• C2IN-	• SCL2A	• RTCC	• C2IN+	• SDA2A	• CVREF-	• C2OUT	• SCL3A	• CVREF+	• PMA0	• SDA3A	• CVREFOUT	• PMA1
• SCL1A	• TMS	• C1IN-																							
• SDA1A	• TCK	• C1IN+																							
• SCL2	• TDI	• C1OUT																							
• SDA2	• TDO	• C2IN-																							
• SCL2A	• RTCC	• C2IN+																							
• SDA2A	• CVREF-	• C2OUT																							
• SCL3A	• CVREF+	• PMA0																							
• SDA3A	• CVREFOUT	• PMA1																							



**TABLE B-2: MAJOR SECTION UPDATES (CONTINUED)**

Section Name	Update Description
<b>Section 4.0 “Memory Organization”</b>	<p>Added new devices and updated the virtual and physical memory map values in Figure 4-1.</p> <p>Added new devices to Figure 4-2.</p> <p>Added new devices to the following register maps:</p> <ul style="list-style-type: none"> <li>• Table 4-3, Table 4-4, Table 4-6 and Table 4-7 (Interrupt Register Maps)</li> <li>• Table 4-12 (I2C2 Register Map)</li> <li>• Table 4-15 (SPI1 Register Map)</li> <li>• Table 4-24 through Table 4-35 (PORTA-PORTG Register Maps)</li> <li>• Table 4-36 and Table 4-37 (Change Notice and Pull-up Register Maps)</li> <li>• Table 4-45 (CAN1 Register Map)</li> <li>• Table 4-46 (CAN2 Register Map)</li> <li>• Table 4-47 (Ethernet Controller Register Map)</li> </ul> <p>Changed the bits named POSCMD to POSCMOD in Table 4-42 (Device Configuration Word Summary).</p>
<b>Section 28.0 “Special Features”</b>	<p>Changed all references of POSCMD to POSCMOD in the Device Configuration Word 1 register (see Register 28-2).</p>
<b>Appendix A: “Migrating from PIC32MX3XX/4XX to PIC32MX5XX/6XX/7XX Devices”</b>	<p>Added the new section <b>A.3 “Pin Assignments”</b>.</p>

# PIC32MX5XX/6XX/7XX

## Revision D (June 2010)

The revision includes the following updates, as described in Table B-3:

**TABLE B-3: MAJOR SECTION UPDATES**

Section Name	Update Description
<b>“High-Performance, USB, CAN and Ethernet 32-bit Flash Microcontrollers”</b>	Updated the initial Flash memory range to 64K. Updated the initial SRAM memory range to 16K.
<b>Section 4.0 “Memory Organization”</b>	Added new Memory Maps (Figure 4-1, Figure 4-2 and Figure 4-3). The bit named I2CSIF was changed to I2C1SIF and the bit named I2CBIF was changed to I2C1BIF in the Interrupt Register Map tables (Table 4-2, Table 4-3, Table 4-4, Table 4-5, Table 4-6 and Table 4-7) Made the following bit name changes in the I2C1, I2C1A, I2C2A and I2C3A Register Map (Table 4-11): <ul style="list-style-type: none"><li>• I2C1ABRG SFR: I2C1BRG was changed to I2C1ABRG</li><li>• I2C2ABRG SFR: I2C1BRG was changed to I2C2ABRG</li><li>• I2C3ABRG SFR: I2C1BRG was changed to I2C3ABRG</li><li>• I2C2ATRN SFR: I2CT1DATA was changed to I2CT2ADATA</li><li>• I2C2ARCV SFR: I2CR2DATA was changed to I2CR2ADATA</li><li>• I2C3ATRN SFR: I2CT1DATA was changed to I2CT3ADATA</li><li>• I2C3ARCV SFR: I2CR1DATA was changed to I2CR3ADATA</li></ul> Added the RTSMD bit and UEN<1:0> bits to the UART1A, UART1B, UART2A, UART2B, UART3A and UART3B Register Map (Table 4-13) Added the SIDL bit to the DMA Global Register Map (Table 4-17). Changed the CM bit to CMR in the System Control Register Map (Table 4-23).
<b>Section 31.0 “Electrical Characteristics”</b>	Updated the Typical and Maximum DC Characteristics: Operating Current (IDD) in Table 31-5. Updated the Typical and Maximum DC Characteristics: Idle Current (IIDLE) in Table 31-6. Updated the Typical and Maximum DC Characteristics: Power-Down Current (IPD) in Table 31-7. Added DC Characteristics: Program Memory parameters D130a and D132a in Table 31-10. Added the Internal Voltage Reference parameter (D305) to the Comparator Specifications in Table 31-12.

## INDEX

### Numerics

10-Bit Analog-to-Digital Converter (ADC) ..... 143

### A

AC Characteristics ..... 182  
 10-Bit Conversion Rate Parameters ..... 206  
 A/D Conversion Requirements ..... 207  
 ADC Specifications ..... 204  
 EJTAG Timing Requirements ..... 214  
 Ethernet ..... 203  
 Internal FRC Accuracy ..... 184  
 Internal RC Accuracy ..... 184  
 OTG Electrical Specifications ..... 213  
 Parallel Master Port Read Requirements ..... 211  
 Parallel Master Port Write ..... 212  
 Parallel Master Port Write Requirements ..... 212  
 Parallel Slave Port Requirements ..... 210  
 PLL Clock Timing ..... 184

### Assembler

MPASM Assembler ..... 170

### B

#### Block Diagrams

A/D Module ..... 143  
 Comparator I/O Operating Modes ..... 149  
 Comparator Voltage Reference ..... 151  
 Connections for On-Chip Voltage Regulator ..... 164  
 Core and Peripheral Modules ..... 25  
 DMA ..... 119  
 Ethernet Controller ..... 147  
 I2C Circuit ..... 136  
 Input Capture ..... 129  
 Interrupt Controller ..... 111  
 JTAG Programming, Debugging and Trace Ports ..... 165  
 MCU ..... 41  
 Output Compare Module ..... 131  
 PIC32MX CAN Module ..... 145  
 PMP Pinout and Connections to External Devices ..... 139  
 Prefetch Module ..... 117  
 Reset System ..... 109  
 RTCC ..... 141  
 SPI Module ..... 133  
 Timer1 ..... 125  
 Timer2/3/4/5 (16-Bit) ..... 127  
 Typical Multiplexed Port Structure ..... 123  
 UART ..... 137  
 WDT and Power-up Timer ..... 163

#### Brown-out Reset (BOR)

and On-Chip Voltage Regulator ..... 164

### C

#### C Compilers

MPLAB C18 ..... 170

Clock Diagram ..... 115

#### Comparator

Specifications ..... 180

Comparator Module ..... 149

Comparator Voltage Reference (CVref) ..... 151

Configuration Bit ..... 155

Controller Area Network (CAN) ..... 145

CPU Module ..... 37

### D

DC Characteristics ..... 174

I/O Pin Input Specifications ..... 178

I/O Pin Output Specifications ..... 179

Idle Current (I<sub>IDLE</sub>) ..... 176

Operating Current (I<sub>DD</sub>) ..... 175

Power-Down Current (I<sub>PD</sub>) ..... 177

Program Memory ..... 179

Temperature and Voltage Specifications ..... 174

Development Support ..... 169

Direct Memory Access (DMA) Controller ..... 119

### E

Electrical Characteristics ..... 173

AC ..... 182

Errata ..... 23

Ethernet Controller ..... 147

#### External Clock

Timer1 Timing Requirements ..... 188

Timer2, 3, 4, 5 Timing Requirements ..... 189

Timing Requirements ..... 183

### F

Flash Program Memory ..... 107

RTSP Operation ..... 107

### I

I/O Ports ..... 123

Parallel I/O (PIO) ..... 124

Instruction Set ..... 167

Inter-Integrated Circuit (I2C) ..... 135

Internal Voltage Reference Specifications ..... 181

Interrupt Controller ..... 111

IRG, Vector and Bit Location ..... 112

### M

#### MCU

Architecture Overview ..... 42

Coprocessor 0 Registers ..... 44

Core Exception Types ..... 45

EJTAG Debug Support ..... 46

Power Management ..... 46

MCU Module ..... 41

Memory Map ..... 49

Memory Maps ..... 48, 50

Memory Organization ..... 47

Layout ..... 47

#### Migration

PIC32MX3XX/4XX to PIC32MX5XX/6XX/7XX ..... 229

MPLAB ASM30 Assembler, Linker, Librarian ..... 170

MPLAB Integrated Development Environment Software ..... 169

MPLAB PM3 Device Programmer ..... 172

MPLAB REAL ICE In-Circuit Emulator System ..... 171

MPLINK Object Linker/MPLIB Object Librarian ..... 170

### O

Open-Drain Configuration ..... 124

Oscillator Configuration ..... 115

Output Compare ..... 131

### P

Packaging ..... 215

Details ..... 217

Marking ..... 215

# PIC32MX5XX/6XX/7XX

Parallel Master Port (PMP) .....	139	I2Cx Bus Data Requirements (Slave Mode).....	200
PIC32MX Family USB Interface Diagram .....	122	Input Capture Requirements.....	189
Pinout I/O Descriptions (table) .....	26	Output Compare Requirements.....	190
Power-on Reset (POR) and On-Chip Voltage Regulator.....	164	Simple OCx/PWM Mode Requirements .....	190
Power-Saving Features.....	153	SPIx Master Mode (CKE = 0) Requirements.....	191
CPU Halted Methods .....	153	SPIx Master Mode (CKE = 1) Requirements.....	192
Operation .....	153	SPIx Slave Mode (CKE = 1) Requirements.....	194
with CPU Running.....	153	SPIx Slave Mode Requirements (CKE = 0).....	193
Prefetch Cache .....	117	<b>U</b>	
Program Flash Memory Wait State Characteristics.....	180	UART .....	137
<b>R</b>		USB On-The-Go (OTG).....	121
Real-Time Clock and Calendar (RTCC).....	141	<b>V</b>	
Register Maps .....	51–105	VCAP/VDDCORE pin.....	164
Registers		Voltage Reference Specifications.....	181
DDPCON (Debug Data Port Control).....	166	Voltage Regulator (On-Chip) .....	164
DEVCFG0 (Device Configuration Word 0 .....	155	<b>W</b>	
DEVCFG1 (Device Configuration Word 1 .....	157	Watchdog Timer (WDT).....	163
DEVCFG2 (Device Configuration Word 2 .....	159	WWW, On-Line Support .....	23
DEVCFG3 (Device Configuration Word 3.....	161		
DEVID (Device and Revision ID) .....	162		
Resets .....	109		
Revision History .....	230		
<b>S</b>			
Serial Peripheral Interface (SPI) .....	133		
Software Simulator (MPLAB SIM).....	171		
Special Features .....	155		
<b>T</b>			
Timer1 Module .....	125		
Timer2/3, Timer4/5 Modules .....	127		
Timing Diagrams			
10-Bit A/D Conversion (CHPS<1:0> = 01, SIMSAM = 0, ASAM = 0, SSRC<2:0> = 000) .....	208		
10-Bit A/D Conversion (CHPS<1:0> = 01, SIMSAM = 0, ASAM = 1, SSRC<2:0> = 111, SAMC<4:0> = 00001).....	209		
CAN I/O.....	202		
EJTAG .....	214		
External Clock.....	182		
I/O Characteristics .....	185		
I2Cx Bus Data (Master Mode) .....	196		
I2Cx Bus Data (Slave Mode) .....	199		
I2Cx Bus Start/Stop Bits (Master Mode).....	196		
I2Cx Bus Start/Stop Bits (Slave Mode).....	199		
Input Capture (CAPx).....	189		
OCx/PWM .....	190		
Output Compare (OCx).....	190		
Parallel Master Port Read.....	211		
Parallel Master Port Write .....	212		
Parallel Slave Port .....	210		
SPIx Master Mode (CKE = 0).....	191		
SPIx Master Mode (CKE = 1).....	192		
SPIx Slave Mode (CKE = 0).....	193		
SPIx Slave Mode (CKE = 1).....	194		
Timer1, 2, 3, 4, 5 External Clock.....	188		
UART Reception .....	138		
UART Transmission (8-Bit or 9-Bit Data) .....	138		
Timing Requirements			
CLKO and I/O .....	185		
Timing Specifications			
CAN I/O Requirements .....	202		
I2Cx Bus Data Requirements (Master Mode).....	197		

## Product Identification System

To order or obtain information, e.g., on pricing or delivery, refer to the factory or the listed sales office.

	<b>PIC32 MX 5XX F 512 H T - 80 I / PT - XXX</b>	
<b>Microchip Brand</b>	_____	<b>Example:</b> PIC32MX575F256H-80I/PT: General purpose PIC32MX, 256 KB program memory, 64-pin, Industrial temperature, TQFP package.
<b>Architecture</b>	_____	
<b>Product Groups</b>	_____	
<b>Flash Memory Family</b>	_____	
<b>Program Memory Size (KB)</b>	_____	
<b>Pin Count</b>	_____	
<b>Tape and Reel Flag (if applicable)</b>	_____	
<b>Speed</b>	_____	
<b>Temperature Range</b>	_____	
<b>Package</b>	_____	
<b>Pattern</b>	_____	

<b>Flash Memory Family</b>	
<b>Architecture</b>	MX = 32-bit RISC MCU core
<b>Product Groups</b>	5XX = General purpose microcontroller family 6XX = General purpose microcontroller family 7XX = General purpose microcontroller family
<b>Flash Memory Family</b>	F = Flash program memory
<b>Program Memory Size</b>	256 = 256K 512 = 512K
<b>Pin Count</b>	H = 64-pin L = 100-pin
<b>Speed</b>	80 = 80 MHz
<b>Temperature Range</b>	I = -40°C to +85°C (Industrial)
<b>Package</b>	PT = 64-Lead (10x10x1 mm) TQFP (Thin Quad Flatpack) PT = 100-Lead (12x12x1 mm) TQFP (Thin Quad Flatpack) PF = 100-Lead (14x14x1 mm) TQFP (Thin Quad Flatpack) MR = 64-Lead (9x9x0.9 mm) QFN (Plastic Quad Flat) BG = 121-Lead (10x10x1.1 mm) XBGA (Plastic Thin Profile Ball Grid Array)
<b>Pattern</b>	Three-digit QTP, SQTP, Code or Special Requirements (blank otherwise) ES = Engineering Sample



---

## WORLDWIDE SALES AND SERVICE

---

### AMERICAS

**Corporate Office**  
2355 West Chandler Blvd.  
Chandler, AZ 85224-6199  
Tel: 480-792-7200  
Fax: 480-792-7277  
Technical Support:  
<http://support.microchip.com>  
Web Address:  
[www.microchip.com](http://www.microchip.com)

**Atlanta**  
Duluth, GA  
Tel: 678-957-9614  
Fax: 678-957-1455

**Boston**  
Westborough, MA  
Tel: 774-760-0087  
Fax: 774-760-0088

**Chicago**  
Itasca, IL  
Tel: 630-285-0071  
Fax: 630-285-0075

**Cleveland**  
Independence, OH  
Tel: 216-447-0464  
Fax: 216-447-0643

**Dallas**  
Addison, TX  
Tel: 972-818-7423  
Fax: 972-818-2924

**Detroit**  
Farmington Hills, MI  
Tel: 248-538-2250  
Fax: 248-538-2260

**Kokomo**  
Kokomo, IN  
Tel: 765-864-8360  
Fax: 765-864-8387

**Los Angeles**  
Mission Viejo, CA  
Tel: 949-462-9523  
Fax: 949-462-9608

**Santa Clara**  
Santa Clara, CA  
Tel: 408-961-6444  
Fax: 408-961-6445

**Toronto**  
Mississauga, Ontario,  
Canada  
Tel: 905-673-0699  
Fax: 905-673-6509

### ASIA/PACIFIC

**Asia Pacific Office**  
Suites 3707-14, 37th Floor  
Tower 6, The Gateway  
Harbour City, Kowloon  
Hong Kong  
Tel: 852-2401-1200  
Fax: 852-2401-3431

**Australia - Sydney**  
Tel: 61-2-9868-6733  
Fax: 61-2-9868-6755

**China - Beijing**  
Tel: 86-10-8528-2100  
Fax: 86-10-8528-2104

**China - Chengdu**  
Tel: 86-28-8665-5511  
Fax: 86-28-8665-7889

**China - Chongqing**  
Tel: 86-23-8980-9588  
Fax: 86-23-8980-9500

**China - Hong Kong SAR**  
Tel: 852-2401-1200  
Fax: 852-2401-3431

**China - Nanjing**  
Tel: 86-25-8473-2460  
Fax: 86-25-8473-2470

**China - Qingdao**  
Tel: 86-532-8502-7355  
Fax: 86-532-8502-7205

**China - Shanghai**  
Tel: 86-21-5407-5533  
Fax: 86-21-5407-5066

**China - Shenyang**  
Tel: 86-24-2334-2829  
Fax: 86-24-2334-2393

**China - Shenzhen**  
Tel: 86-755-8203-2660  
Fax: 86-755-8203-1760

**China - Wuhan**  
Tel: 86-27-5980-5300  
Fax: 86-27-5980-5118

**China - Xian**  
Tel: 86-29-8833-7252  
Fax: 86-29-8833-7256

**China - Xiamen**  
Tel: 86-592-2388138  
Fax: 86-592-2388130

**China - Zhuhai**  
Tel: 86-756-3210040  
Fax: 86-756-3210049

### ASIA/PACIFIC

**India - Bangalore**  
Tel: 91-80-3090-4444  
Fax: 91-80-3090-4123

**India - New Delhi**  
Tel: 91-11-4160-8631  
Fax: 91-11-4160-8632

**India - Pune**  
Tel: 91-20-2566-1512  
Fax: 91-20-2566-1513

**Japan - Yokohama**  
Tel: 81-45-471- 6166  
Fax: 81-45-471-6122

**Korea - Daegu**  
Tel: 82-53-744-4301  
Fax: 82-53-744-4302

**Korea - Seoul**  
Tel: 82-2-554-7200  
Fax: 82-2-558-5932 or  
82-2-558-5934

**Malaysia - Kuala Lumpur**  
Tel: 60-3-6201-9857  
Fax: 60-3-6201-9859

**Malaysia - Penang**  
Tel: 60-4-227-8870  
Fax: 60-4-227-4068

**Philippines - Manila**  
Tel: 63-2-634-9065  
Fax: 63-2-634-9069

**Singapore**  
Tel: 65-6334-8870  
Fax: 65-6334-8850

**Taiwan - Hsin Chu**  
Tel: 886-3-6578-300  
Fax: 886-3-6578-370

**Taiwan - Kaohsiung**  
Tel: 886-7-536-4818  
Fax: 886-7-536-4803

**Taiwan - Taipei**  
Tel: 886-2-2500-6610  
Fax: 886-2-2508-0102

**Thailand - Bangkok**  
Tel: 66-2-694-1351  
Fax: 66-2-694-1350

### EUROPE

**Austria - Wels**  
Tel: 43-7242-2244-39  
Fax: 43-7242-2244-393

**Denmark - Copenhagen**  
Tel: 45-4450-2828  
Fax: 45-4485-2829

**France - Paris**  
Tel: 33-1-69-53-63-20  
Fax: 33-1-69-30-90-79

**Germany - Munich**  
Tel: 49-89-627-144-0  
Fax: 49-89-627-144-44

**Italy - Milan**  
Tel: 39-0331-742611  
Fax: 39-0331-466781

**Netherlands - Drunen**  
Tel: 31-416-690399  
Fax: 31-416-690340

**Spain - Madrid**  
Tel: 34-91-708-08-90  
Fax: 34-91-708-08-91

**UK - Wokingham**  
Tel: 44-118-921-5869  
Fax: 44-118-921-5820